

SmartSlice GRT1-Series  
GRT1-PRT

# **PROFIBUS Communication Unit**

# **OPERATION MANUAL**

**OMRON**

**SmartSlice GRT1-Series  
GRT1-PRT  
PROFIBUS Communication Unit  
Operation Manual**



*Revised November 27, 2006*



## Notice:

OMRON products are manufactured for use by a trained operator and only for the purposes described in this manual.

The following conventions are used to classify and explain the precautions in this manual. Always heed the information provided with them.

-  **DANGER** Indicates information that, if not heeded, is likely to result in serious injury or loss of life.
-  **WARNING** Indicates information that, if not heeded, could possibly result in serious injury or loss of life.
-  **Caution** Indicates information that, if not heeded, could possibly result in minor or relatively serious injury, damage to the product or faulty operation.

## OMRON Product References

All OMRON products are capitalized in this manual. The first letter of the word *Unit* is also capitalized when it refers to an OMRON product, regardless of whether it appears in the proper name of the product.

The abbreviation *Ch* appears in some displays and on some OMRON products. It often means *word* and is abbreviated as *Wd* in the documentation.

The abbreviation *PLC* means Programmable Logic Controller.

## Visual Aids

The following headings appear in the left column of the manual to help you locate different types of information.

**Note** Indicates information of particular interest for efficient and convenient operation of the product.

**1, 2, 3...**Indicates various lists such as procedures, checklists etc.

## ***Trademarks and Copyrights***

PROFIBUS, PROFIBUS FMS, PROFIBUS DP, and PROFIBUS PA are trademarks of PROFIBUS International.

Microsoft, Windows, Windows NT, Windows 2000, Windows XP, Windows Explorer and ActiveX are trademarks of Microsoft Corporation.

Other product names and company names in this manual are trademarks or registered trademarks of their respective companies.

The copyright of the GRT1-PRT PROFIBUS Communication Unit belongs to OMRON Corporation.

### **© OMRON, 2006**

All rights reserved. No part of this publication may be reproduced, stored in a retrieval system, or transmitted, in any form, or by any means, mechanical, electronic, photocopying, recording, or otherwise, without the prior written permission of OMRON.

No patent liability is assumed with respect to the use of the information contained herein. Moreover, because OMRON is constantly striving to improve its high-quality products, the information contained in this manual is subject to change without notice. Every precaution has been taken in the preparation of this manual. Nevertheless, OMRON assumes no responsibility for errors or omissions. Neither is any liability assumed for damages resulting from the use of the information contained in this publication.

# TABLE OF CONTENTS

<b>About this Manual</b> .....	<b>vii</b>
<b>PRECAUTIONS</b> .....	<b>xiii</b>
1 Intended Audience .....	xiv
2 General Precautions .....	xiv
3 Safety Precautions .....	xiv
4 Operating Environment Precautions .....	xv
5 Application Precautions .....	xvi
6 Conformance to EC Directives .....	xvii
<b>SECTION 1</b>	
<b>Features and Specifications</b> .....	<b>1</b>
1-1 Overview of GRT1-Series SmartSlice I/O Units .....	2
1-2 GRT1-PRT PROFIBUS Communication Unit .....	3
1-3 GRT1-PRT Configuration .....	7
1-4 Basic Operating Procedure .....	9
<b>SECTION 2</b>	
<b>Installation and Wiring</b> .....	<b>11</b>
2-1 Unit Components .....	12
2-2 Installing the GRT1-PRT Unit .....	16
2-3 Wiring the GRT1-PRT .....	20
2-4 Setting up a PROFIBUS Network .....	24
2-5 Installation of Configuration Software .....	28
<b>SECTION 3</b>	
<b>Setup and Operation</b> .....	<b>31</b>
3-1 Station Address Settings and I/O Allocation .....	32
3-2 Unit Functions .....	36
3-3 Setup the GRT1-PRT Configuration .....	42
3-4 Operating the Network .....	52
3-5 Remote Communication Characteristics .....	55
<b>SECTION 4</b>	
<b>Troubleshooting and Maintenance</b> .....	<b>59</b>
4-1 Overview .....	60
4-2 Troubleshooting using the LED Indicators .....	60
4-3 Other Errors .....	64
4-4 Maintenance .....	69
4-5 Replacing the Unit .....	70

# TABLE OF CONTENTS

## Appendices

A	PROFIBUS Technology .....	71
B	Slave Diagnostics Message .....	77
C	Explicit Messages .....	81

<b>Index.....</b>	<b>87</b>
-------------------	-----------

<b>Revision History .....</b>	<b>91</b>
-------------------------------	-----------

# About this Manual

This manual describes the GRT1-PRT PROFIBUS Communication Unit for OMRON's SmartSlice I/O Units. It also describes how to install and operate the Unit.

Please read this manual carefully so that you understand the information provided before installing or using the GRT1-PRT Unit. Start with the precautions in the following section. They describe the operating environment and application safety measures which must be observed prior to and when using the GRT1-PRT Unit.

The sections of this manual are as follows:

**Section 1** introduces the GRT1-PRT Unit.

**Section 2** describes the installation and setup of the GRT1-PRT Unit.

**Section 3** describes the FINS commands supported by the GRT1-PRT Unit.

**Section 4** describes the operational aspects of the GRT1-PRT Unit.

**Section 5** provides procedures for troubleshooting the GRT1-PRT Unit.

The **Appendices** contain information supplementary to the information in the main body of the manual. They are referred to in the various sections as required.

Manual	Products	Contents	Cat. No.
GRT1-series Slice I/O Units Operation Manual	GRT1-series SmartSlice I/O Units	Describes the Installation and Operation of the GRT1 SmartSlice I/O Units.	W455-E1-□
CS/CJ-series PROFIBUS DP Master Units Operation Manual	SYSMAC CS/CJ-series CS1W-PRM21 CJ1W-PRM21 PROFIBUS DP Units	Describes the installation and operation of the CS1W-PRM21 and CJ1W-PRM21 PROFIBUS Units.	W409-E2-□
CX-Programmer Operation Manual	SYSMAC WS02-CXP□□-E CX-Programmer	Provides information on how to use the CX-Programmer, programming software which supports CS1/CJ1-series PLCs.	W446-E1-□
C200H-series PROFIBUS DP Master Units Operation Manual	SYSMAC C200H-series C200HW-PRM21	Describes the Installation and Operation of the C200HW-PRM21 PROFIBUS DP Master Units.	W349-E2-□
CJ-series PROFIBUS DP Slave unit Operation Manual	SYSMAC CJ1-series CJ1W-PRT21	Describes the Installation and Operation of the CJ1W-PRT21 PROFIBUS DP Slave Units.	W408-E2-□
GRT1-series Devicenet Communications Unit Operation Manual	GRT1-series GRT1-DRT Devicenet Communications Unit	Describes the Installation and Operation of the GRT1-DRT Devicenet Communications Unit.	W454-E1-□

 **WARNING** Failure to read and understand the information provided in this manual may result in personal injury or death, damage to the product, or product failure. Please read each section in its entirety and be sure you understand the information provided in the section and related sections before attempting any of the procedures or operations given.





## ***Read and Understand this Manual***

Please read and understand this manual before using the product. Please consult your OMRON representative if you have any questions or comments.

## ***Warranty and Limitations of Liability***

### ***WARRANTY***

OMRON's exclusive warranty is that the products are free from defects in materials and workmanship for a period of one year (or other period if specified) from date of sale by OMRON.

OMRON MAKES NO WARRANTY OR REPRESENTATION, EXPRESS OR IMPLIED, REGARDING NON-INFRINGEMENT, MERCHANTABILITY, OR FITNESS FOR PARTICULAR PURPOSE OF THE PRODUCTS. ANY BUYER OR USER ACKNOWLEDGES THAT THE BUYER OR USER ALONE HAS DETERMINED THAT THE PRODUCTS WILL SUITABLY MEET THE REQUIREMENTS OF THEIR INTENDED USE. OMRON DISCLAIMS ALL OTHER WARRANTIES, EXPRESS OR IMPLIED.

### ***LIMITATIONS OF LIABILITY***

OMRON SHALL NOT BE RESPONSIBLE FOR SPECIAL, INDIRECT, OR CONSEQUENTIAL DAMAGES, LOSS OF PROFITS OR COMMERCIAL LOSS IN ANY WAY CONNECTED WITH THE PRODUCTS, WHETHER SUCH CLAIM IS BASED ON CONTRACT, WARRANTY, NEGLIGENCE, OR STRICT LIABILITY.

In no event shall the responsibility of OMRON for any act exceed the individual price of the product on which liability is asserted.

IN NO EVENT SHALL OMRON BE RESPONSIBLE FOR WARRANTY, REPAIR, OR OTHER CLAIMS REGARDING THE PRODUCTS UNLESS OMRON'S ANALYSIS CONFIRMS THAT THE PRODUCTS WERE PROPERLY HANDLED, STORED, INSTALLED, AND MAINTAINED AND NOT SUBJECT TO CONTAMINATION, ABUSE, MISUSE, OR INAPPROPRIATE MODIFICATION OR REPAIR.

# ***Application Considerations***

## ***SUITABILITY FOR USE***

OMRON shall not be responsible for conformity with any standards, codes, or regulations that apply to the combination of products in the customer's application or use of the products.

At the customer's request, OMRON will provide applicable third party certification documents identifying ratings and limitations of use that apply to the products. This information by itself is not sufficient for a complete determination of the suitability of the products in combination with the end product, machine, system, or other application or use.

The following are some examples of applications for which particular attention must be given. This is not intended to be an exhaustive list of all possible uses of the products, nor is it intended to imply that the uses listed may be suitable for the products:

- Outdoor use, uses involving potential chemical contamination or electrical interference, or conditions or uses not described in this manual.
- Nuclear energy control systems, combustion systems, railroad systems, aviation systems, medical equipment, amusement machines, vehicles, safety equipment, and installations subject to separate industry or government regulations.
- Systems, machines, and equipment that could present a risk to life or property.

Please know and observe all prohibitions of use applicable to the products.

**NEVER USE THE PRODUCTS FOR AN APPLICATION INVOLVING SERIOUS RISK TO LIFE OR PROPERTY WITHOUT ENSURING THAT THE SYSTEM AS A WHOLE HAS BEEN DESIGNED TO ADDRESS THE RISKS, AND THAT THE OMRON PRODUCTS ARE PROPERLY RATED AND INSTALLED FOR THE INTENDED USE WITHIN THE OVERALL EQUIPMENT OR SYSTEM.**

## ***PROGRAMMABLE PRODUCTS***

OMRON shall not be responsible for the user's programming of a programmable product, or any consequence thereof.

# **Disclaimers**

## ***CHANGE IN SPECIFICATIONS***

Product specifications and accessories may be changed at any time based on improvements and other reasons.

It is our practice to change model numbers when published ratings or features are changed, or when significant construction changes are made. However, some specifications of the products may be changed without any notice. When in doubt, special model numbers may be assigned to fix or establish key specifications for your application on your request. Please consult with your OMRON representative at any time to confirm actual specifications of purchased products.

## ***DIMENSIONS AND WEIGHTS***

Dimensions and weights are nominal and are not to be used for manufacturing purposes, even when tolerances are shown.

## ***PERFORMANCE DATA***

Performance data given in this manual is provided as a guide for the user in determining suitability and does not constitute a warranty. It may represent the result of OMRON's test conditions, and the users must correlate it to actual application requirements. Actual performance is subject to the OMRON Warranty and Limitations of Liability.

## ***ERRORS AND OMISSIONS***

The information in this manual has been carefully checked and is believed to be accurate; however, no responsibility is assumed for clerical, typographical, or proofreading errors, or omissions.



# PRECAUTIONS

This section provides general precautions for using the GRT1-Series modules, Programmable Controllers and related devices.

**The information contained in this section is important for the safe and reliable operation of the GRT1-PRT PROFIBUS Communication Unit. You must read this section and understand the information contained before attempting to set up or operate a GRT1-PRT PROFIBUS Communication Unit and related systems.**

1	Intended Audience .....	xiv
2	General Precautions .....	xiv
3	Safety Precautions .....	xiv
4	Operating Environment Precautions .....	xv
5	Application Precautions .....	xvi
6	Conformance to EC Directives .....	xvii
6-1	Applicable Directives .....	xvii
6-2	Concepts .....	xvii
6-3	Conformance to EC Directives .....	xviii

## 1 Intended Audience

This manual is intended for the following personnel, who must also have a knowledge of electrical systems (an electrical engineer or the equivalent).

- Personnel in charge of installing FA systems.
- Personnel in charge of designing FA systems.
- Personnel in charge of managing FA systems and facilities.

## 2 General Precautions

The user must operate the product according to the performance specifications described in the operation manuals.

Before using the product under conditions which are not described in the manual or applying the product to nuclear control systems, railroad systems, aviation systems, vehicles, combustion systems, medical equipment, amusement machines, safety equipment, and other systems, machines, and equipment that may have a serious influence on lives and property if used improperly, consult your OMRON representative.

Make sure that the ratings and performance characteristics of the product are sufficient for the systems, machines, and equipment, and be sure to provide the systems, machines, and equipment with double safety mechanisms.

This manual provides information for installing and operating the OMRON GRT1-PRT PROFIBUS Communication Unit. Be sure to read this manual before attempting to use the Unit and keep this manual close at hand for reference during operation.

 **WARNING** It is extremely important that the Unit is used for its specified purpose and under the specified conditions, especially in applications that can directly or indirectly affect human life. You must consult your OMRON representative before using it in a system in the above-mentioned applications.

## 3 Safety Precautions

 **WARNING** Never attempt to disassemble any Units or touch the terminal block while power is being supplied. Doing so may result in serious electrical shock or electrocution.

 **WARNING** Provide safety measures in external circuits (i.e., not in the Programmable Controller), including the following items, to ensure safety in the system if an abnormality occurs due to malfunction of the PLC or another external factor affecting the PLC operation. Not doing so may result in serious accidents.

- Emergency stop circuits, interlock circuits, limit circuits, and similar safety measures must be provided in external control circuits.
- The PLC will stop operation when its self-diagnosis function detects any error or when a severe failure alarm (FALS) instruction is executed. As a countermeasure for such errors, external safety measures must be provided to ensure safety in the system.

- The PLC outputs may remain ON or OFF due to deposits on or burning of the output relays, or destruction of the output transistors. As a countermeasure for such problems, external safety measures must be provided to ensure safety in the system.
- When the 24V DC output (service power supply to the PLC) is overloaded or short-circuited, the voltage may drop and result in the outputs being turned OFF. As a countermeasure for such problems, external safety measures must be provided to ensure safety in the system.
- SmartSlice I/O Terminals will continue operating even if one or more I/O Units is removed from or falls out of the SmartSlice I/O Terminal, i.e., the other I/O Units will continue control operations, including outputs. As a countermeasure for such a possibility, external safety measures must be provided to ensure safety in the system.

 **WARNING** The CPU Unit refreshes I/O even when the program is stopped (i.e., even in PROGRAM mode). Confirm safety thoroughly in advance before changing the status of any part of memory allocated to Output Units, Special I/O Units, or CPU Bus Units. Any changes to the data allocated to any Unit may result in unexpected operation of the loads connected to the Unit. Any of the following operations may result in changes to memory status.

- Transferring I/O memory data to the CPU Unit from a Programming Device
- Changing present values in memory from a Programming Device
- Force-setting/-resetting bits from a Programming Device
- Transferring I/O memory files from a Memory Card or EM file memory to the CPU Unit
- Transferring I/O memory from a host computer or from another PLC on a network

## 4 Operating Environment Precautions

 **Caution** Do not operate the Unit in the following places:

- Locations subject to direct sunlight.
- Locations subject to temperatures or humidities outside the range specified in the specifications.
- Locations subject to condensation as the result of severe changes in temperature.
- Locations subject to corrosive or flammable gases.
- Locations subject to dust (especially iron dust) or salt.
- Locations subject to exposure to water, oil, or chemicals.
- Locations subject to shock or vibration.

Provide proper shielding when installing in the following locations:

- Locations subject to static electricity or other sources of noise.
- Locations subject to strong electromagnetic fields.
- Locations subject to possible exposure to radiation.
- Locations near to power supply lines.



 **Caution** The operating environment of the GRT1-PRT PROFIBUS Communication Unit can have a large effect on the longevity and reliability of the system. Unsuitable operating environments can lead to malfunction, failure and other unforeseeable problems with the system. Ensure that the operating environment is within the specified conditions at installation time and remains that way during the life of the system. Follow all installation instructions and precautions provided in the operation manuals.

## 5 Application Precautions

Observe the following precautions when using the GRT1-PRT PROFIBUS Communication Unit.

 **WARNING** Failure to abide by the following precautions could lead to serious or possibly fatal injury. Always heed these precautions.

- Always connect to a class-3 ground (100  $\Omega$  or less) when installing the Units.

 **Caution** Failure to abide by the following precautions could lead to faulty operation of the Unit or the system. Always heed these precautions.

- Install double safety mechanisms to ensure safety against incorrect signals that may be produced by broken signal lines or momentary power interruptions.
- When adding a new device to the network, make sure that the baud rate is the same as other stations.
- When adding a new SmartSlice I/O Unit to the Communication Unit, make sure that the GRT1-PRT PROFIBUS Communication Unit is powered down, to prevent unexpected results when starting up the new station.
- Use specified communication cables.
- Do not extend connection distances beyond the ranges given in the specifications.
- Always turn OFF the power supply to the personal computer, Slaves, and Communication Units before attempting any of the following:
  - Mounting or dismounting the GRT1-PRT PROFIBUS Communication Unit, Power Supply Units, I/O Units, CPU Units, or any other Units.
  - Assembling a Unit.
  - Setting DIP-switches or rotary switches.
  - Connecting or wiring the cables.
  - Connecting or disconnecting connectors.
- Be sure that all the mounting screws, terminal screws, Unit mounting screws, and cable connector screws are tightened to the torque specified in the relevant manuals. Incorrect tightening torque may result in malfunction.
- Always use the power supply voltage specified in this manual.
- Double-check all the wiring and connection of terminal blocks and connectors before mounting the Units.

- Take appropriate measures to prevent foreign objects from entering the unit when mounting or wiring it. Failure to do so, may result in unit damage, electric shock or fire.
- Use crimp terminals for wiring. Do not connect bare stranded wires directly to terminals.
- Observe the following precautions when wiring the communication cable.
  - Separate the communication cables from the power lines or high-tension lines.
  - Do not bend the communication cables.
  - Do not pull on the communication cables.
  - Do not place heavy objects on top of the communication cables.
  - Be sure to wire communication cable inside ducts.
  - Use appropriate communication cables.
- Take appropriate measures to ensure that the specified power with the rated voltage and frequency is supplied in places where the power supply is unstable. An incorrect power supply may result in malfunction.
- Install external breakers and take other safety measures against short-circuits in external wiring. Insufficient safety measures against short-circuits may result in burning.
- Double-check all the wiring and switch settings before turning ON the power supply.
- When transporting or storing the product, cover the PCB's with electrically conductive materials to prevent LSI's and IC's from being damaged by static electricity, and also keep the product within the specified storage temperature range.
- When transporting the Unit, use special packing boxes and protect it from being exposed to excessive vibration or impacts during transportation.
- Do not attempt to disassemble, repair, or modify any Units.

## 6 Conformance to EC Directives

### 6-1 Applicable Directives

- EMC Directives
- Low voltage directive

### 6-2 Concepts

OMRON units complying with EC Directives also conform to related product standards making them easier to incorporate in other units or machines. The actual products have been checked for conformity to product standards. Whether the products conform to the standards in the system used by the customer, however, must be checked by the customer.

Product related performance of OMRON units complying with EC Directives will vary depending on the configuration, wiring, and other conditions of the equipment or control panel in which OMRON devices are installed. The customer must, therefore, perform final checks to confirm that units and the overall system conforms to product standards.

A Declaration of Conformity for the GRT1-PRT PROFIBUS Communication Unit can be requested at your nearest OMRON representative.

### **6-3 Conformance to EC Directives**

PROFIBUS units should be installed as follows, for the complete configuration to meet the EC directives:

- 1,2,3...**
1. The units are designed for installation inside control panels. All units must be installed within control panels.
  2. Use reinforced insulation or double insulation for the DC power supplies used for the communication power supply, internal circuit power supply, and the I/O power supplies.
  3. The GRT1-PRT PROFIBUS Communication Unit product meets the generic emission standard. However as EMC performance can vary in the final installation, additional measures may be required to meet the standards. It should therefore be verified that the overall machine or device also meets the relevant standards. You must therefore confirm that EC directives are met for the overall machine or device, particularly for the radiated emission requirement (10 m).

# SECTION 1

## Features and Specifications

This section provides an introductory overview of the GRT1 series SmartSlice I/O Units and the GRT1-PRT PROFIBUS, Communication Unit, its functions and how to setup and configure it for a PROFIBUS network.

1-1	Overview of GRT1-Series SmartSlice I/O Units .....	2
1-2	GRT1-PRT PROFIBUS Communication Unit .....	3
1-2-1	Features.....	3
1-2-2	System Configuration.....	4
1-2-3	Specifications .....	5
1-3	GRT1-PRT Configuration.....	7
1-4	Basic Operating Procedure .....	9
1-4-1	Overview.....	9
1-4-2	Preparations for Use .....	10

## 1-1 Overview of GRT1-Series SmartSlice I/O Units

The GRT1-Series SmartSlice I/O Units are building-block style I/O devices, which can be expanded in small I/O increments. This provides the possibility to configure I/O systems which exactly match the various customer applications. SmartSlice I/O Units communicate with the PROFIBUS DP-V1 Master Unit by remote I/O communication through a PROFIBUS Communication Unit. The figure below shows a typical I/O configuration.

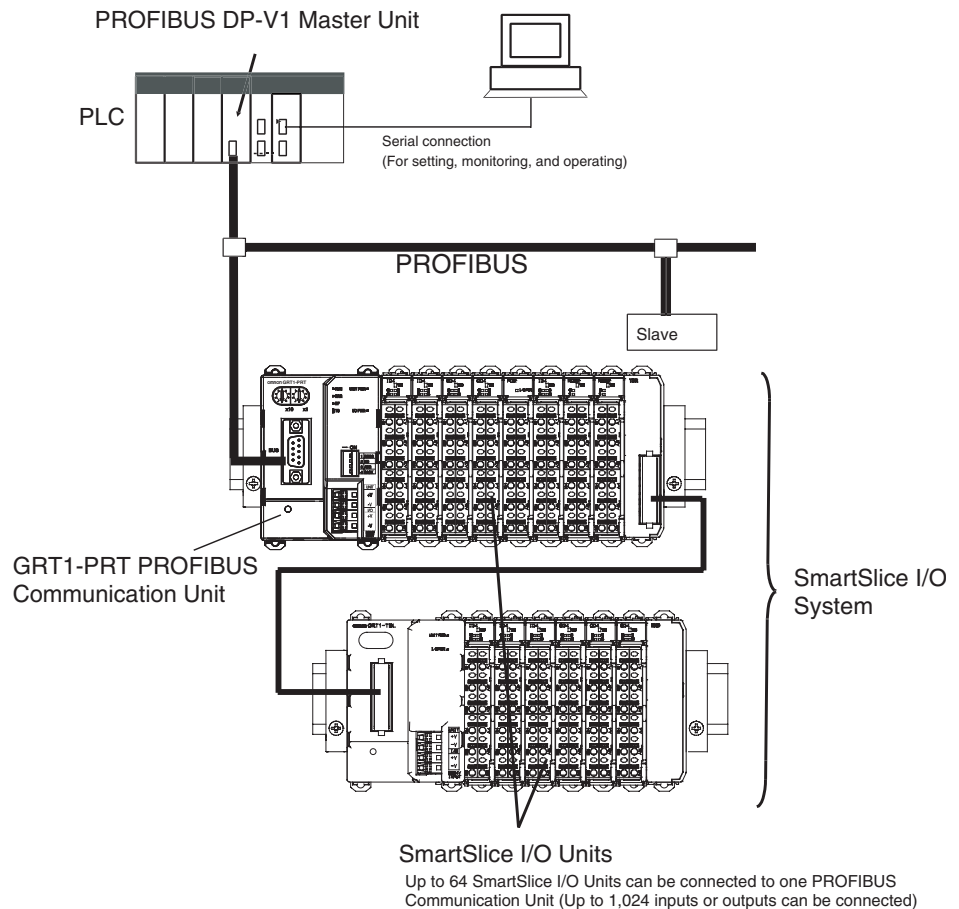

SmartSlice I/O configurations can be very compact, consisting of only a few I/O points, but they can also be extended, to up to 64 I/O slices. The slice configuration can also be subdivided over two or more blocks using local extension units and extension cables, as shown in the figure above.

### GRT1-Series SmartSlice I/O Units

The GRT1-Series of SmartSlice I/O Units and Communication Units is constantly being expanded with new Units. Refer to the latest revisions of the *GRT1 Series SmartSlice I/O Units Operation Manual (W455)* and the *GRT1-DRT DeviceNet Communication Unit Operation Manual (W454)* for currently available units in the GRT1-Series.

## 1-2 GRT1-PRT PROFIBUS Communication Unit

### 1-2-1 Features

The GRT1-PRT PROFIBUS Communication Unit for SmartSlice I/O controls data exchange between the PROFIBUS DP-V1 Master and SmartSlice I/O Units over the PROFIBUS DP network. For an overview of the PROFIBUS technology refer to *Appendix A PROFIBUS Technology*.

#### Manage Multiple SmartSlice I/O Units as One Slave

A single PROFIBUS Communication Unit with up to 64 connected SmartSlice I/O Units can be managed as a single slave device from the PROFIBUS DP-V1 Master.

#### I/O Data Exchange

Cyclic I/O data exchange is used to exchange I/O data between the PROFIBUS Master and SmartSlice I/O Units through the PROFIBUS Communication Unit. In addition to I/O data, various status information in the PROFIBUS Communication Unit as well as in the individual I/O slices can be accessed from the PROFIBUS DP-V1 Master Unit.

#### Simplified Startup

The PROFIBUS Communication Unit can be set up easily, just by wiring the Unit, setting the PROFIBUS station address on the Unit's rotary switches, and making simple DIP switch settings.

The Unit's configuration is read automatically when the power is turned ON and I/O is also automatically allocated in the SmartSlice I/O Units. It is not necessary to make any settings with a special Programming Device.

#### Simplified I/O Wiring

All of the SmartSlice I/O Units that connect to a PROFIBUS Communication Unit are equipped with screw-less clamp terminal blocks. Wiring to external I/O is accomplished just by inserting the wire into the terminals, eliminating the need to tighten terminal screws.

#### Table Registration

The configuration of the SmartSlice I/O Units (mounting order and I/O size) connected to a PROFIBUS Communication Unit can be registered in a table simply by switching a pin on the PROFIBUS Communication Unit's DIP switch. Once the table has been registered, the actual configuration is compared to the registered configuration each time that the power is turned ON. If the configuration does not match, a status flag can be turned ON in the PROFIBUS DP-V1 Master to indicate the error.

#### Communication Error Log Monitor

The communication error log in the PROFIBUS Communication Unit can record the four most recent communication errors in the PROFIBUS DP network and the 64 most recent SmartSlice I/O Unit errors. The communication error information (communication error cause code and communication power supply voltage when error occurred) can be read with an explicit message command or from the Configurator.

#### Online Replacement of I/O Units

The SmartSlice I/O Unit's circuit section can be removed, so it is not necessary to turn OFF the power to replace a Unit. Communication can be maintained in the remaining (connected) Units.

#### Parameter Backup and Restore

Before replacing a SmartSlice I/O Unit for maintenance, the parameter data set in the I/O Unit can be backed up in the PROFIBUS Communication Unit by switching a pin on the Communication Unit's DIP switch. After the I/O Unit has been replaced, another DIP switch operation can be used to select the mode that automatically writes the backed-up parameter data to the appropriate Units.

**Automatic Baud Rate Recognition**

The PROFIBUS Communication Unit automatically detects the Master’s communication baud rate, so it is not necessary to set the baud rate. (If the Master’s baud rate has been changed, the PROFIBUS Communication Unit must be turned OFF and then ON again to change its baud rate.)

**1-2-2 System Configuration**

The PROFIBUS Communication Unit connects to the Master by a network cable and it connects to the SmartSlice I/O Units by directly coupling the Units with slide connectors.

**I/O Data Exchange**

The I/O Unit data in the PROFIBUS Communication Unit is shared with the Master’s Input and Output Areas through the PROFIBUS DP network. The I/O Units’ data is collected in the PROFIBUS Communication Unit and exchanged with the Master asynchronously.

**Messaging Services**

The GRT1-PRT PROFIBUS Communication Unit also supports messaging services, allowing the user to send acyclic message commands addressed to the GRT1-PRT Unit or individual SmartSlice I/O Units.

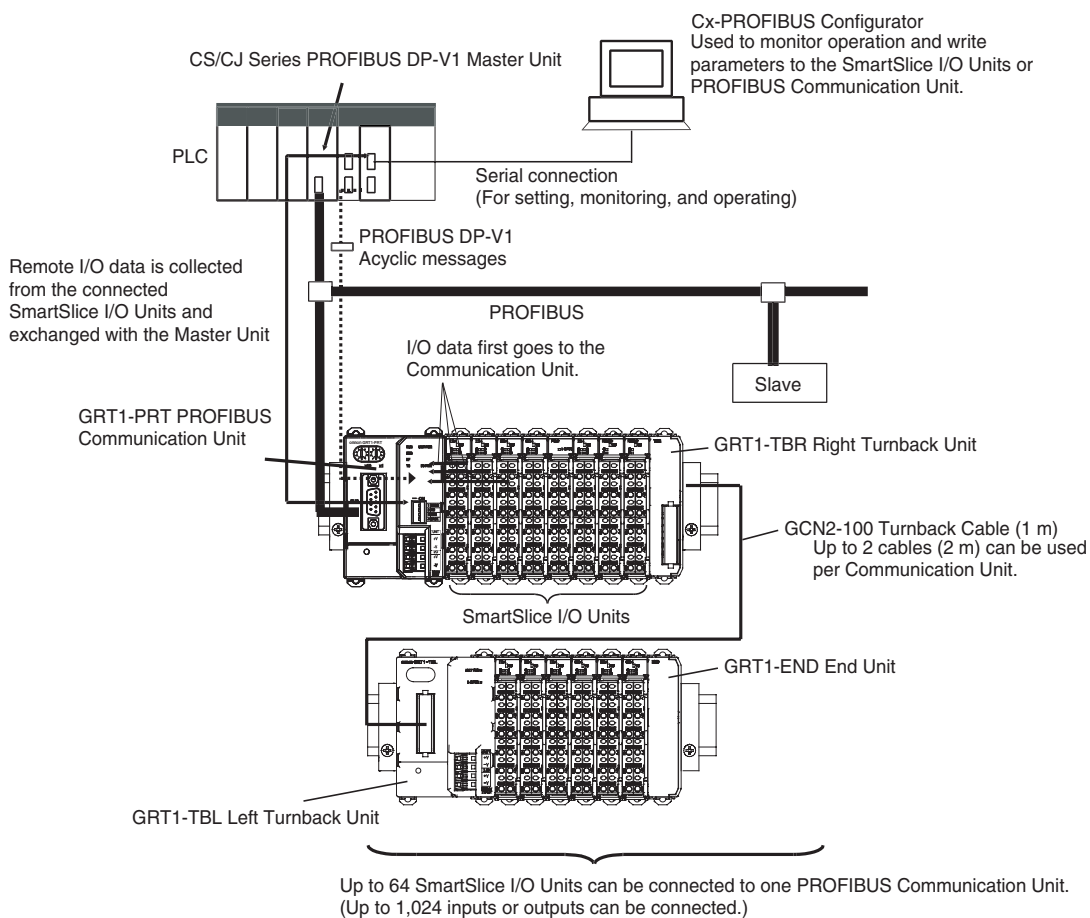

**Note** Always install an End Unit on the last I/O Unit in the system.

## 1-2-3 Specifications

### Functional Specifications

	Item	Specification
Installation	Unit type	SmartSlice GRT1 series
	Model	GRT1-PRT
	Mounting position	DIN Rail mounted
	Power supply	24 Vdc +10% -15% (20.4 to 26.4 Vdc)
	Current consumption	103 mA (max), 90 mA typical at 24 Vdc
	Dimensions (W x H x D)	58 x 80 x 70mm
	Weight	135g (typical)
Environment	Ambient operating temperature	-10 to 55° C (no icing or condensation)
	Ambient operating humidity	25% to 85% Relative Humidity
	Storage temperature	-20 to 65° C (no icing or condensation)
	Vibration resistance	10 to 57Hz, 0.7-mm amplitude 57 to 150Hz, acceleration: 49 m/s <sup>2</sup>
	Shock resistance	150 m/s <sup>2</sup>
	Dielectric strength	500 VAC (between isolated circuits)
	Conformance to EMC and Electrical safety standards	EN61131-2:2003
	Enclosure rating	IP20
Front case	Settings, rotary switches	2 Slave address rotary switches, range: 0 ~ 99 (Decimal)
	Settings DIP-switches	4 DIP-switches on the front of the Unit: <ul style="list-style-type: none"> <li>• Switch 1: Create / Enable Registration Table</li> <li>• Switch 2: Not used.</li> <li>• Switch 3: Automatic Restore</li> <li>• Switch 4: Backup Trigger</li> </ul>
	Indicators	6 LEDs, indicating Unit status, Slice I/O status and PROFIBUS status: <p>Unit status:            RUN (Green LED)                               ERR (Red LED)                               UNIT PWR (Green LED)</p> <p>SmartSlice I/O status: TS (Red/Green LED)                               I/O PWR (Green LED)</p> <p>PROFIBUS status:    BF (Red LED)</p>
	PROFIBUS Connector	9-pin sub-D female connector (#4/40 UNC thread)
	Power connector	Screwless connectors. Unit power and I/O power are separated.
SmartSlice I/O System	Number of connectable SmartSlice I/O Units	64 Units max. Connected directly to the GRT1-PRT or via turnback extension units.
	Baud rate	3 Mbps
	Communication signal level	RS-485
	Communication distance	SmartSlice I/O Units: 64 Units coupled (about 2 m max.) Turnback Cable: 2 m max. (2 cables, 1 m each)
	Turnback Cable	Length 1 m max., up to 2 cables can be connected.
	SmartSlice I/O Unit connections	Building-block style configuration with slide connectors (Units connect with Turnback Cables).
	Baseblock power supply	Voltage: 24 V DC Current: 4 A max
	Event messaging	Supported.



## Protocol Specification

	Item	Specification
PROFIBUS interface	Applicable standards	EN50170, Volume 2 PROFIBUS DP Extensions to EN50170 (DP-V1)
	Protocol type supported	PROFIBUS DP PROFIBUS DP-V1, Class 2
	PROFIBUS Unit type	PROFIBUS DP-V1 Slave
	PROFIBUS Media type	RS-485, galvanically isolated from the PLC
	PROFIBUS Connector	9-pin sub-D female connector (#4/40 UNC thread) Termination according to EN50170 provided by the cable connector
	Unit device address range	0 ~ 99, set through the rotary switches on the front
	baud rates supported	Selectable through the configurator: <ul style="list-style-type: none"> <li>• 9.6 kbit/s</li> <li>• 19.2 kbit/s</li> <li>• 45.45 kbit/s</li> <li>• 93.75 kbit/s</li> <li>• 187 kbit/s</li> <li>• 500 kbit/s</li> <li>• 1.5 Mbit/s</li> <li>• 3 Mbit/s</li> <li>• 6 Mbit/s</li> <li>• 12 Mbit/s</li> </ul>
PROFIBUS DP Services supported	Master Class 1 - Slave cyclic services	<ul style="list-style-type: none"> <li>• Set_Prm</li> <li>• Chk_Cfg</li> <li>• Data_Exchange</li> <li>• Slave_Diag</li> <li>• Global-Control - SYNC / UNSYNC, FREEZE / UNFREEZE, CLEAR</li> <li>• Get_Cfg</li> <li>• Rd_Inp</li> <li>• Rd_Outp</li> </ul>
	Master Class 1 - Slave acyclic services	Not supported
	Master Class 2 - Slave acyclic services	MSAC2_Initiate MSAC2_Read MSAC2_Write MSAC2_Abort
I/O Data	Number of I/O module definitions	65 max. over all configured slave devices
	Number of I/O data	128 bytes max. of Input data 128 bytes max. of output data
	Number of diagnostics data	Up to 36 bytes max. of diagnostics
	GSD file	OC_098F.gsd

## External Dimensions (mm)

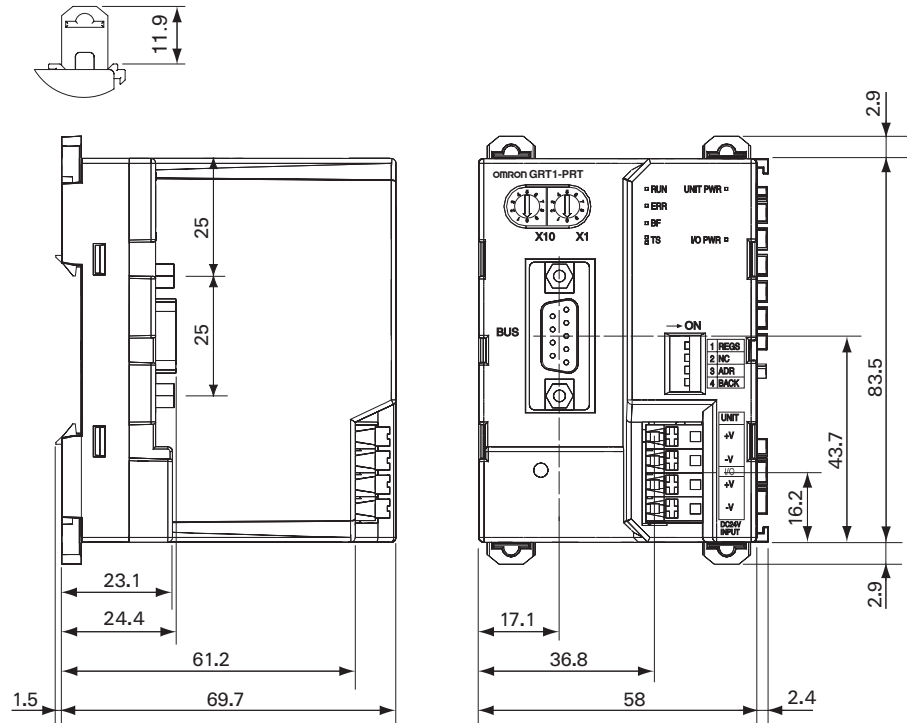

## 1-3 GRT1-PRT Configuration

### PROFIBUS Configuration Means

The PROFIBUS DP Master Unit requires a configuration before it can exchange I/O data with any of its slave devices. For this configuration information on the slave device must be available. OMRON provides two means to facilitate Master Unit configuration.

- A GRT1-PRT DTM
- A GRT1-PRT GSD file

### GRT1-PRT Configuration DTM

The GRT1-PRT DTM is an executable component, provided by OMRON, which requires an FDT Container program like OMRON's Cx-Profibus (refer also to Appendix A-9 *FDT/DTM Technology*). The DTM runs inside this FDT Container and provides its own User Interfaces. It can access GRT1-PRT and SmartSlice I/O Unit data through the PROFIBUS Master unit and present that to the user. It can also save the settings, using the features of the FDT Container program.

The GRT1-PRT DTM, provides the user with the following features.

- Parameter configuration
- I/O Configuration
- Configuration of individual SmartSlice I/O Units
- Monitoring of the SmartSlice I/O System

**Note** In order to configure individual SmartSlice I/O Units, the PROFIBUS Master Unit must support PROFIBUS DP-V1, Class 2 functionality. The OMRON CS1/CJ1W-PRM21 PROFIBUS Master Units support this functionality as of revision 3.

<b>GRT1-PRT Parameter Configuration</b>	<p>The PROFIBUS Parameter User Interface allows the user to set operational parameters for the communication between the PROFIBUS Master and the GRT1-PRT. The User Interface provides entries to set</p> <ul style="list-style-type: none"><li>• the device address (i.e. defining it for communication)</li><li>• the PROFIBUS group allocation for the GRT1-PRT.</li><li>• the FINS fragment length, used in acyclic communication.</li><li>• Specific PROFIBUS Master Unit behaviour with respect to this slave device.</li></ul>
<b>GRT1-PRT I/O Configuration</b>	<p>The I/O Configuration User Interface allows the user to define the configuration of SmartSlice I/O Units attached to the PROFIBUS Communication Unit. It also allows the user to make parameter settings for individual SmartSlice I/O Units.</p> <p>The I/O Configuration is used by the PROFIBUS Master Unit when mapping the I/O data of individual SmartSlice I/O Units on to the PLC memory areas. It is also sent by the PROFIBUS Master Unit to the GRT1-PRT for verification when establishing communication. The I/O Configuration sent by the Master Unit must match the physical configuration attached to the GRT1-PRT PROFIBUS Communication Unit, in order to proceed with I/O data exchange.</p>
<b>Monitoring the SmartSlice I/O System</b>	<p>The Monitoring User Interfaces allows the user to read information from individual SmartSlice I/O Units. It also provides a means to read the Error Log of the GRT1-PRT PROFIBUS Communication Unit.</p>
<b>Configuration via GSD File</b>	<p>The GSD file concept is the older, and consequently more widely used means of configuration. The GSD file for the GRT1-PRT is a text based file, which contains all options required to configure a PROFIBUS Master Unit. The file can be loaded by the configuration software of the Master Units, which will then present the information to the user to allow the appropriate selections to be made.</p> <p>The drawback of the GSD file is that- unlike the GRT1-PRT DTM - it only provides setting options for PROFIBUS DP and PROFIBUS DP-V1. The GSD file does not provide the means to initiate parameter data transfer via PROFIBUS DP-V1 Class 2 messages. These have to be programmed in the Master Unit itself.</p>
<b>Third-Party Master Units</b>	<p>The GSD file for GRT1-PRT can be used to configure most third-party Master Units. The GRT1-PRT GSD file contains all the necessary parameters to allow the user to configure the Master Unit for I/O data exchange.</p>
<b>Note</b>	<ol style="list-style-type: none"><li>1. The GRT1-PRT DTM can also be used in third-party configuration software provided that this software supports the FDT/DTM concept.</li><li>2. With the Cx-Profibus FDT Container OMRON also provides a Generic Slave DTM, an FDT/DTM interface between the FDT Container program and GSD files. Alternatively, this DTM can be used to setup a Master Unit, using the GRT1-PRT GSD file. This Generic Slave DTM however, does not provide the means to initiate PROFIBUS DP-V1 messages.</li></ol>
<b>Downloading the Configuration</b>	<p>After setting up the configuration, it must be downloaded to the PROFIBUS Master Unit. The download process depends on the Master Unit used.</p>

## 1-4 Basic Operating Procedure

### 1-4-1 Overview

The following diagram provides an overview of the installation procedures. For experienced installation engineers, this may provide sufficient information. For others, cross-references are made to various sections of this manual where more explicit information is given.

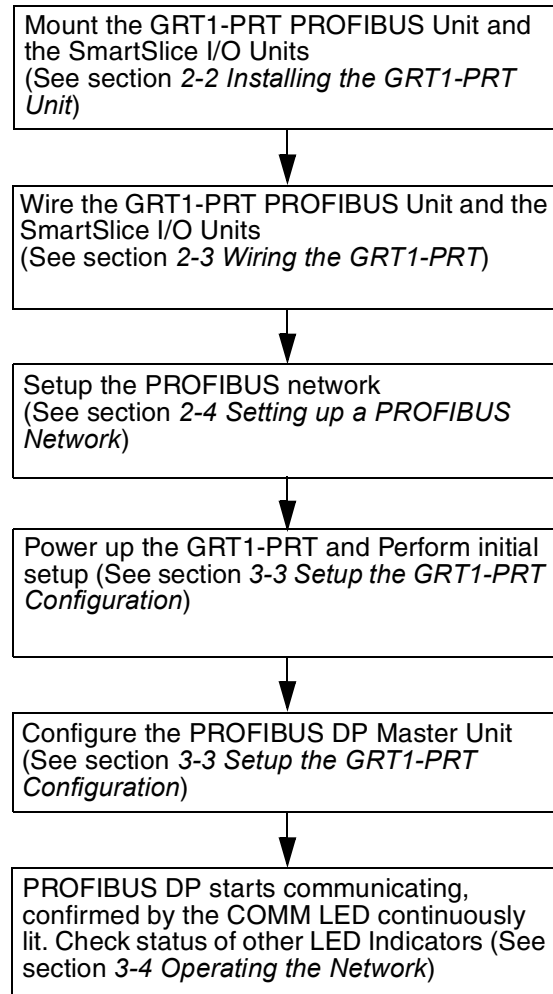

## 1-4-2 Preparations for Use

The following procedure shows the basic steps required before using the PROFIBUS Communication Unit and the SmartSlice I/O Units.

### Initial Setup Procedure

- 1,2,3...**
1. Mount the GRT1-PRT Unit and the SmartSlice I/O system on the DIN rail. The maximum number of SmartSlice I/O Units can be 64.
  2. Wire the SmartSlice I/O Units and the GRT1-PRT Unit's power supply.
  3. Wire the PROFIBUS network, to connect the Unit to the PROFIBUS Master Unit.
  4. Set the rotary switches on the front of the GRT1-PRT to the desired PROFIBUS address.
  5. Turn ON the power to the Unit and the I/O.
  6. Turn ON (from OFF to ON) DIP switch 1 on the front of the PROFIBUS Communication Unit. When switch 1 is turned ON, the existing SmartSlice I/O Unit configuration (connection order and I/O size) is registered in the PROFIBUS Communication Unit as a registered table. After the table is registered, leave pin 1 ON to enable the table.

**Note** The next time the power is turned ON, the actual SmartSlice I/O Unit configuration at power on is automatically compared to the registered table. Any SmartSlice I/O Units that do not match the registered table (connection order or I/O size) will not participate in I/O communication. I/O communication will start with the other SmartSlice I/O Units.

### Configuration Procedure

Use the following procedure to configure the PROFIBUS Master Unit for communication with the PROFIBUS Communication Unit, using the Cx-Profibus FDT Container program and the GRT1-PRT DTM:

- 1,2,3...**
1. In Cx-Profibus, create a network and define the parameters and I/O configurations for the PROFIBUS Master Unit settings and the allocated slave devices. Determine the baud rate and the bus parameter setup. Make sure that the "Go to OPERATE mode" option is selected, to force the Unit to OPERATE mode upon a PLC mode change to RUN / MONITOR mode.
  2. Download the network configuration to the PROFIBUS Master Unit. After downloading the configuration, Cx-Profibus will restart the PROFIBUS DP Master Unit.
  3. After restarting the PROFIBUS DP Master Unit it will automatically start communication.

# SECTION 2

## Installation and Wiring

This section shows the GRT1-series PROFIBUS Communication Unit and identifies its controls and indicators. It contains the procedures for installing and wiring the Communication Unit as well as the GRT1-series SmartSlice I/O Units. It also contains the procedures for setting up the PROFIBUS network.

2-1	Unit Components . . . . .	12
2-1-1	Nomenclature . . . . .	12
2-1-2	LED Indicators . . . . .	12
2-1-3	Switch Settings . . . . .	13
2-1-4	Power Supply Connector . . . . .	15
2-1-5	PROFIBUS Connector . . . . .	15
2-2	Installing the GRT1-PRT Unit . . . . .	16
2-2-1	Handling Precautions . . . . .	16
2-2-2	Installation on a DIN Rail . . . . .	16
2-2-3	Connecting the PROFIBUS Unit and SmartSlice I/O Units . . . . .	18
2-2-4	Connecting Additional SmartSlice I/O Units . . . . .	18
2-3	Wiring the GRT1-PRT . . . . .	20
2-3-1	Connecting the SmartSlice I/O System Power Supply . . . . .	20
2-3-2	Wiring Methods . . . . .	21
2-3-3	Connecting the Turnback Units . . . . .	23
2-4	Setting up a PROFIBUS Network . . . . .	24
2-4-1	Network Structure . . . . .	24
2-4-2	Bus Termination . . . . .	26
2-4-3	PROFIBUS Cable Connector . . . . .	27
2-4-4	Shielding Precautions . . . . .	27
2-5	Installation of Configuration Software . . . . .	28
2-5-1	Installation Requirements . . . . .	28
2-5-2	Installation Procedure . . . . .	28
2-5-3	GRT1-PRT GSD File . . . . .	29

## 2-1 Unit Components

### 2-1-1 Nomenclature

The illustration below shows the Status LED indicators, the PROFIBUS address switches, and a 9-pin female sub-D connector on the front side of the PROFIBUS Communication Unit. Each of these components are explained in the following sections.

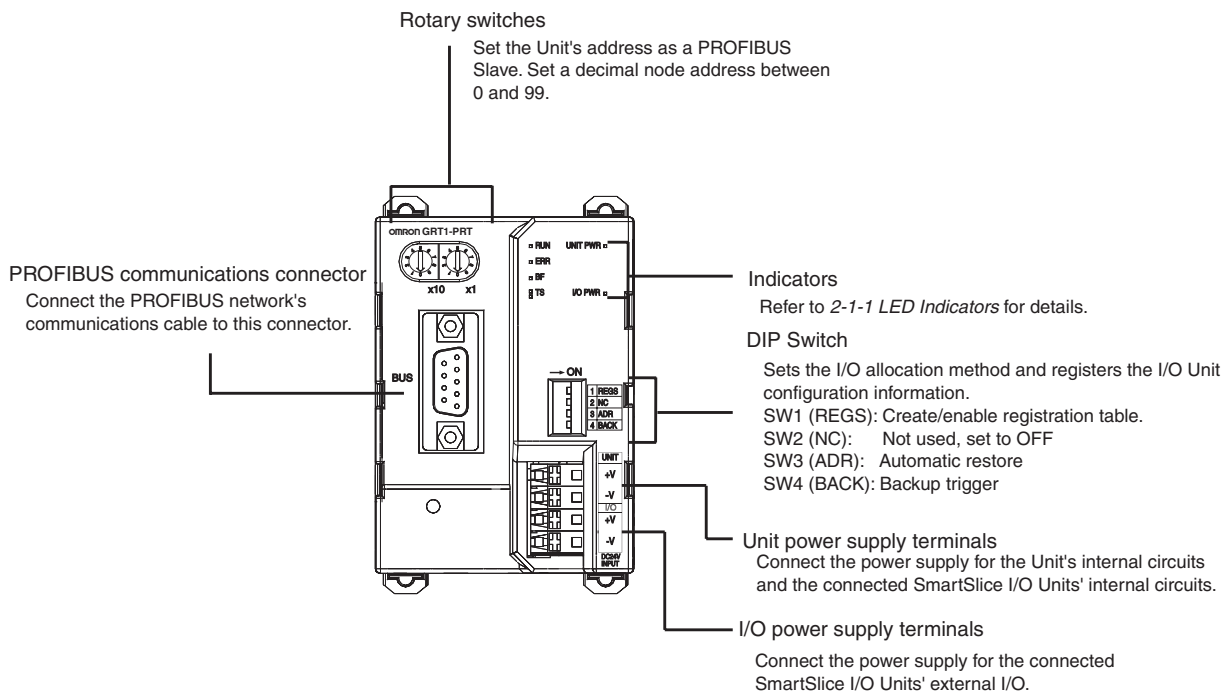

### 2-1-2 LED Indicators

The GRT1-PRT PROFIBUS Communication Unit is fitted with six LED indicators to indicate the operational mode and status of the Unit and the PROFIBUS network.

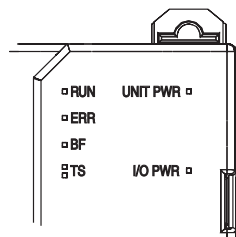

#### Indicator Specifications

Indicator	Colour	Status	Meaning
RUN Unit status	Green	Not lit	<ul style="list-style-type: none"> <li>Startup test failed, Unit not operational.</li> <li>Operation stopped, due to a fatal error.</li> </ul>
		Lit	Initialization successful, Unit is in normal operation.
ERR Unit error	Red	Not lit	Unit is in normal operation.
		Flashing	A startup error has occurred
		Lit	<ul style="list-style-type: none"> <li>Fatal error in program execution.</li> <li>Error Log Read or Write occurred.</li> </ul>

Indicator	Colour	Status	Meaning	
BF PROFIBUS Failure	Red	Not lit	No PROFIBUS communication errors occurred. I/O Data Exchange is in progress.	
		Flashing	The parameter settings sent by the PROFIBUS Master unit are invalid. No I/O Data Exchange is possible.	
		Lit	No PROFIBUS communication has been detected by the Unit.	
TS SmartSlice I/O System communication status	--	Not Lit	<ul style="list-style-type: none"> <li>• Power not being supplied.</li> <li>• Communication has not started with SmartSlice I/O Unit.</li> <li>• Over current detected.</li> </ul>	
		Green	Flashing	SmartSlice I/O Unit added to the system (Flashing once every 1 s) Backup/Restore function operating (Flashing once every 0.5 s) <ul style="list-style-type: none"> <li>• Restoring settings to SmartSlice I/O Unit, backup function operating.</li> <li>• Downloading SmartSlice I/O Unit settings.</li> </ul>
			Lit	Communication with SmartSlice I/O Unit established.
	Red	Flashing	Non-fatal communication error occurred. <ul style="list-style-type: none"> <li>• Communication timeout</li> <li>• Verification error occurred with registered table.</li> <li>• Different model Unit detected after I/O Unit replacement.</li> </ul>	
		Lit	Fatal communication error occurred. Failure occurred while restoring settings to I/O Unit or downloading I/O Unit settings (Lit for 2 s)	
	UNIT PWR	Green	Not Lit	Power supply to the Unit is not present (All other LED indicators are also OFF).
Lit			Power supply to the Unit is present.	
I/O PWR	Green	Not Lit	Power supply to the SmartSlice I/O is not present. The SmartSlice I/O Units may be operative, but no output is available.	
		Lit	Power supply to the SmartSlice I/O is present.	

### 2-1-3 Switch Settings

#### Rotary Switches

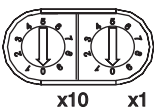

Two rotary switches on the front of the GRT1-PRT, marked x10 and x1, are provided to set the PROFIBUS device address of the Unit. The address can be set in the range of 00 through 99 (decimal). The device address on the Unit must be the same as the address used in the master’s configuration. The device address is used to uniquely identify PROFIBUS Communication Unit on the PROFIBUS DP network. Selecting a non-unique address for the unit will prevent the unit from communicating properly with the Master unit.

In order to set the device address, perform the following steps.

- 1,2,3...**
1. Turn OFF the power supply before setting the device address.
  2. Set the switch to the (new) device address. Use a small screwdriver to make the setting, taking care not to damage the rotary switch. The station address is factory-set to 0.
  3. Turn ON the power again.

- Note**
1. Always turn OFF the power to the Unit before changing the device address setting. The Unit only reads the address setting during the initialization following a power-up, i.e. any changes after power up will have no effect.
  2. The PROFIBUS Communication Unit detects the Master’s communication baud rate automatically. Setting the baud rate is not required.



### DIP Switches

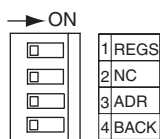

Four DIP switches on the front of the Unit are provided for operational settings. The factory setting is OFF for all DIP switches.

DIP switch	Caption	Description
1	REGS	Create / Enable Registration Table.
2	NC	Not Used (Always OFF).
3	ADR	Automatic Restore.
4	BACK	Backup Trigger.

#### DIP Switch 1: REGS Create / Enable Registration Table

If DIP switch 1 is turned from OFF to ON while the Unit's power is ON, the existing SmartSlice I/O Unit configuration (connection order and I/O size) is registered in the PROFIBUS Communication Unit as a registered table.

If DIP switch 1 is ON when the Unit's power is turned ON, the actual SmartSlice I/O Unit configuration at startup is automatically compared to the registered table. Any SmartSlice I/O Units that do not match the registered table will not participate in SmartSlice I/O communication.

Switch setting	Function
ON	Registered table is enabled. (If there is a verification error, the affected Unit will not participate in communication.)
OFF	Registered table is disabled (All Units participate in communication).
OFF to ON	Register I/O Unit table (Unit Power must be ON)
ON to OFF	Clear registered I/O Unit table (Unit Power must be ON)

#### DIP Switch 2: NC Not Used

DIP switch 2, marked NC is not used and should always be set to OFF.

#### DIP Switch 3: ADR Automatic Restore

When DIP switch 1 is ON (registered table enabled) and DIP switch 3 is switched to ON, parameter data is automatically restored to the SmartSlice I/O Units that had parameter data backed up.

Switch setting	Function
ON	Switch OFF to ON to start the parameter restore (when DIP switch 1 is ON).
OFF	Automatic restore function disabled.

#### DIP Switch 4: BACK Backup Trigger

When DIP switch 1 is ON (registered table enabled) and DIP switch 4 is turned OFF to ON, the parameter data of all connected SmartSlice I/O Units is backed up in the Communication Unit.

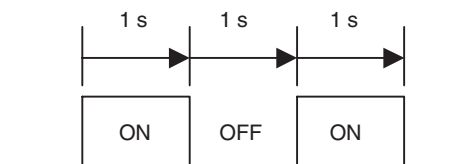

The backup operation starts after DIP switch 4 is turned from ON to OFF to ON within 3 seconds.

Switch setting	Function
ON	Switch ON to OFF to ON to start the parameter backup (when DIP switch 1 is ON).
OFF	---

**Note** It is recommended to leave DIP switches 1, 3 and 4 always ON.

### 2-1-4 Power Supply Connector

The PROFIBUS Communication Unit provides two 24VDC power supply terminals on the front of the Unit.

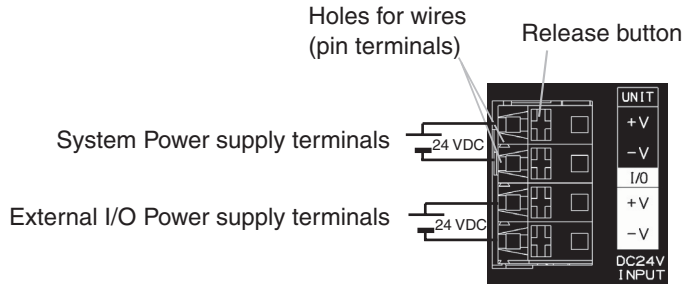

Power supply terminals	Description
Unit power supply terminals	These terminals supply power to the PROFIBUS Communication Unit's internal circuits as well as the connected SmartSlice I/O Units' internal circuits (supplied through the SmartSlice bus).
I/O power supply terminals	These terminals supply power to the external I/O that is connected to the System's SmartSlice I/O Units.

**Note** System Power supply and External I/O power supply are not transferred through the GCN2-100 Turnback cable. The GRT1-TBR units provide the same set of Power supply terminals as the PROFIBUS Communication Unit.

### 2-1-5 PROFIBUS Connector

The PROFIBUS connector on the front of the Unit is a 9-pin female sub-D connector, as recommended by the PROFIBUS standard EN50170.

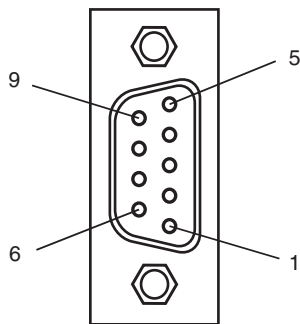

Pin No.	Signal	Description
1	Shield	Shield/protective ground
2	--	
3	B-line	Receive/Transmit data - plus (B wire)
4	RTS	Control signal for repeaters (direction control) (TTL)
5	DGND	Data ground (reference potential for VP)
6	VP	Supply voltage of the terminator resistance (5 Vdc)
7	--	
8	A-line	Receive/Transmit data - minus (A wire)
9	-	-

The signal RTS (TTL signal) is for the direction control of repeaters, which do not have a self-controlling capability.

The signals DGND and VP are used to power the bus terminator located in the cable connector.

- Note**
1. The orientation of the sub-D connector allows the use of PROFIBUS connectors with a 90° angle cable outlet, e.g ERNI, Delconec and Phoenix.
  2. The 9-pin sub-D connector uses #4/40 UNC thread for mechanical fixation of the cable connector. Make sure that if non-standard PROFIBUS connectors are used, the same thread is used on the cable connector.
  3. PROFIBUS DP Baud rate setting is accomplished through automatic detection, all the defined PROFIBUS DP baud rate values are supported.

## 2-2 Installing the GRT1-PRT Unit

### 2-2-1 Handling Precautions

When installing the PROFIBUS Communication Unit and the SmartSlice I/O Units, observe the following handling precautions

- Always turn OFF the power supply to the PROFIBUS Communication Unit, the SmartSlice I/O Units and the external I/O, before mounting or dismounting a Unit or connecting or disconnecting cables.
- Do not connect or disconnect the PROFIBUS Communication Unit's communication cable while the PROFIBUS network is operating. Short-circuits or poor contacts in the PROFIBUS cable may prevent normal communication.
- Ensure that the power supplies for the PROFIBUS Communication Unit and the SmartSlice I/O Units and the external I/O are wired correctly.
- Provide separate conduits or ducts for the I/O lines to prevent noise from high-tension lines or power lines.

The SmartSlice I/O system is installed and set up as a PROFIBUS DP-V1 Slave. The PROFIBUS Communication Unit's communication connector connects to the Master Unit through a PROFIBUS communication cable. Up to 64 SmartSlice I/O Units can be connected to one GRT1-PRT Unit.

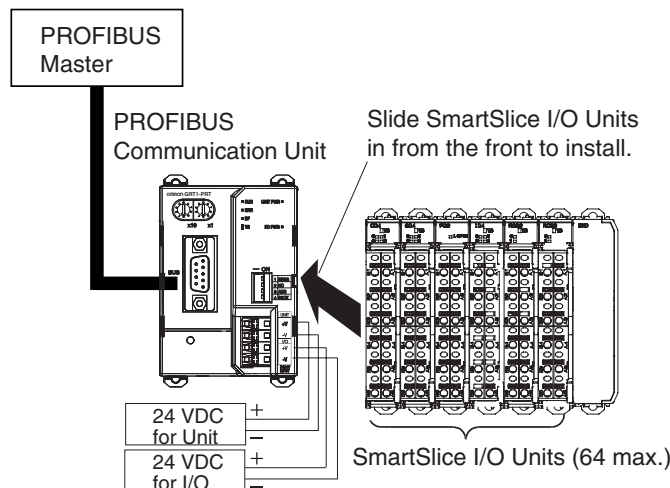

### 2-2-2 Installation on a DIN Rail

#### DIN Rail Installation

The GRT1-PRT and SmartSlice I/O Units must be mounted on a DIN Rail. Attach the DIN Rail with screws in every fourth mounting hole.

PF50N (50 cm) or PF100N (100 cm) DIN Rail

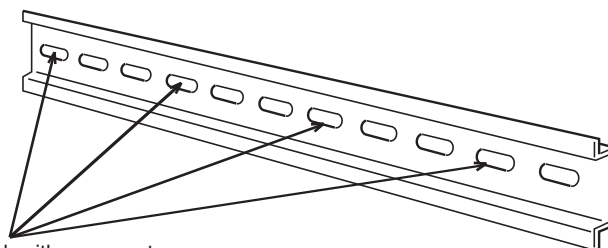

Attach the track with screws at a maximum spacing of 105 mm between adjacent screws.

**SmartSlice I/O System Orientation**

There is no restriction regarding orientation of the SmartSlice I/O System. The system can be mounted in any of the following 6 directions.

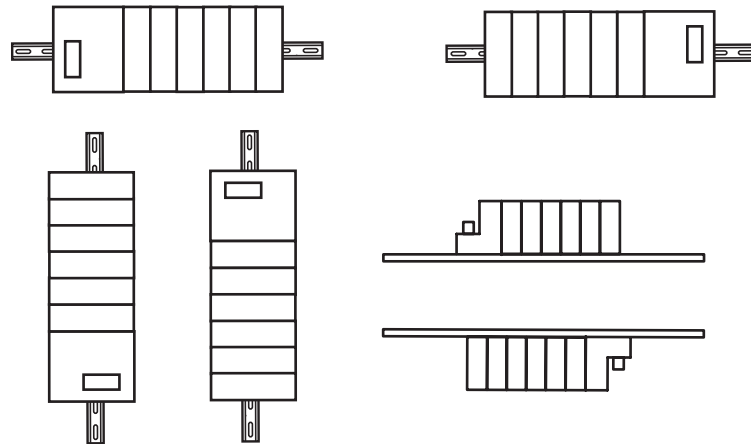

**Installing a Unit**

To install a PROFIBUS Communication Unit on the DIN Rail, press the Unit onto the DIN Track from the front. Press the Unit firmly until it clicks, indicating that the Unit's DIN Rail Mounting Hooks have all locked onto the DIN Rail.

When the Unit is pushed onto the DIN Rail, verify that the Mounting Hooks have locked.

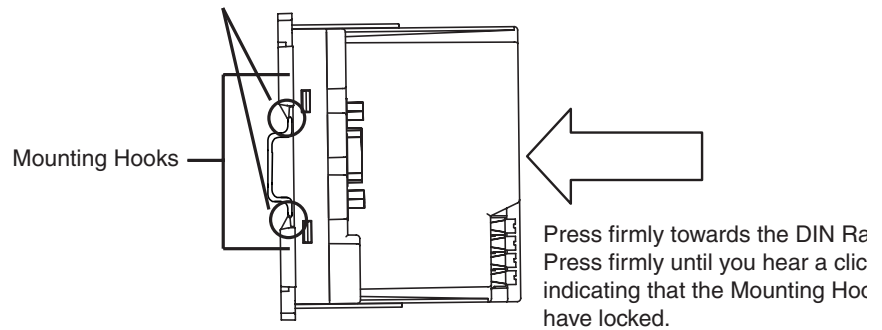

**Removing a Unit**

Use a standard screwdriver to release the DIN Rail Mounting Hooks at the top and bottom of the Unit and pull the Unit straight away from the DIN Rail.

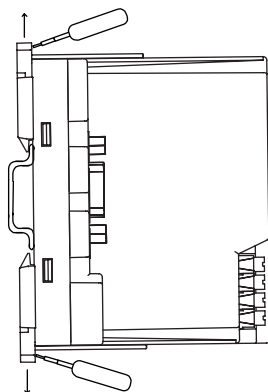

### 2-2-3 Connecting the PROFIBUS Unit and SmartSlice I/O Units

Connect the first SmartSlice I/O Unit to the PROFIBUS Communication Unit by aligning the sides of the Units and sliding in the SmartSlice I/O Unit from the front. Additional SmartSlice I/O Units can be connected consecutively to the first.

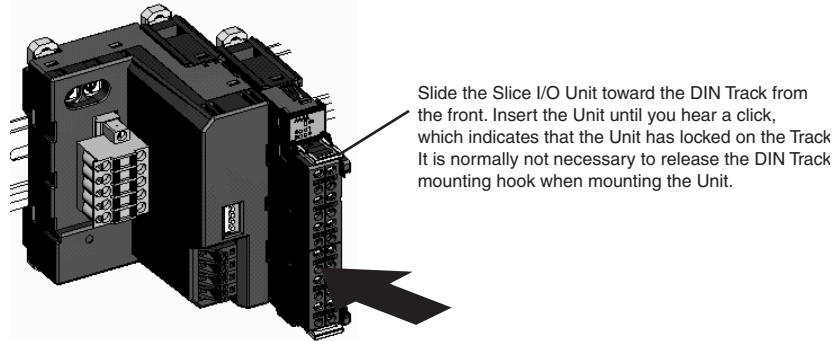

**Note** Do not touch the connector on the Unit's base block.

### 2-2-4 Connecting Additional SmartSlice I/O Units

Connect additional SmartSlice I/O Units by aligning the sides of the Units and sliding in the next Unit from the front. Up to 64 SmartSlice I/O Units can be connected to one PROFIBUS Communication Unit.

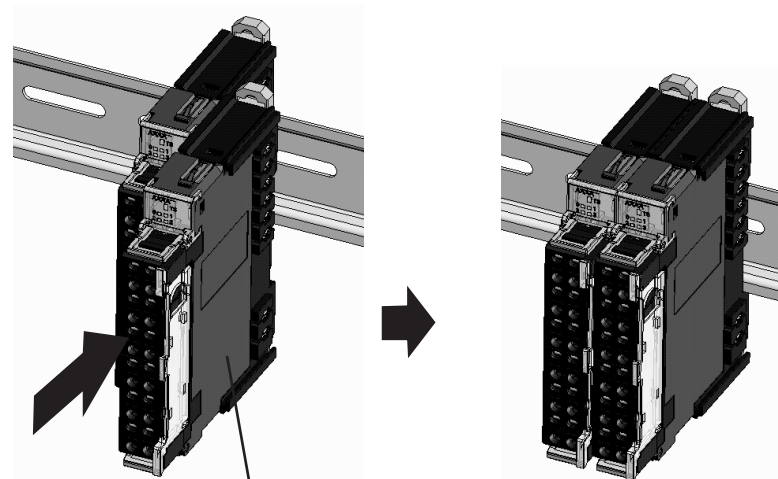

Slide the Unit to the DIN Track from the front. Insert the Unit until you hear a click, which indicates that the Unit has locked on the Track. It is normally not necessary to release the DIN Track mounting hook when mounting the Unit.

### Connecting Turnback Units

When a SmartSlice I/O System is divided into blocks, connect a GRT1-TBR Right Turnback Unit to the right end of the first block. Connect a GRT1-TBL Left Turnback Unit to the left side of the expansion block and connect additional SmartSlice I/O Units. Use a GCN2-100 Turnback Cable to connect the Turnback Units together.

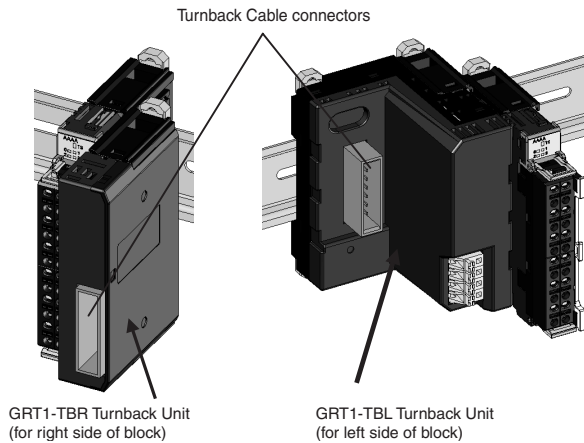

**Note** The Turnback Units can be used to divide a SmartSlice I/O System into up to three blocks.

**Connecting the End Unit**

A GRT1-END End Unit must be connected at the end of the SmartSlice I/O System.

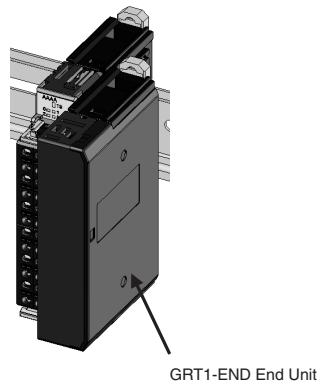

**Installing the End Plates**

Always secure the SmartSlice I/O System on the DIN Rail by installing End Plates on both sides of the System. First hook the bottom of the End Plate on the bottom edge of the DIN Rail (1), attach the top of the End Plate, and pull the End Plate down onto the top edge of the DIN Rail (2). Tighten the End Plate's securing screw.

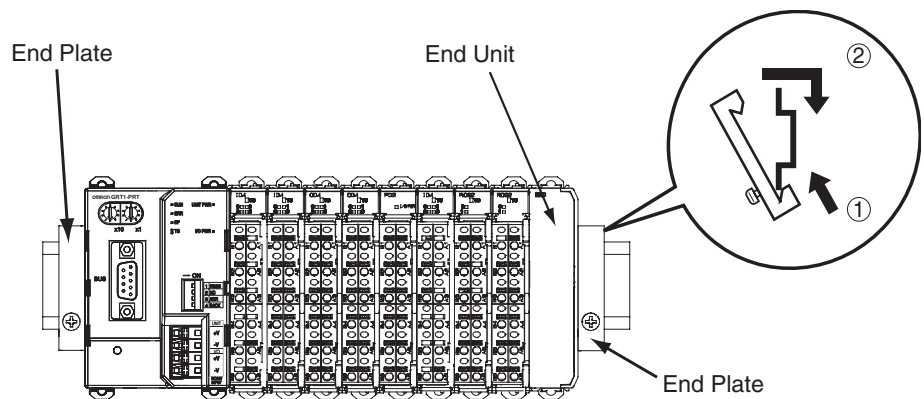

**Note** Always secure the SmartSlice I/O System by attaching End Plates on both ends.

## 2-3 Wiring the GRT1-PRT

### 2-3-1 Connecting the SmartSlice I/O System Power Supply

The PROFIBUS Communication Unit has two sets of power supply terminals for the following two systems.

Power supply terminals	Description
Unit power supply terminals	These terminals supply power to the PROFIBUS Communication Unit's internal circuits as well as the connected SmartSlice I/O Units' internal circuits (supplied through the SmartSlice bus).
I/O power supply terminals	These terminals supply power to the external I/O that is connected to the System's SmartSlice I/O Units.

Both the SmartSlice I/O System power supply and the external I/O power supply are connected with screwless clamping-type terminals.

#### Evaluating the Power Supply Requirements

##### Unit Power Supply

The maximum power consumption for SmartSlice I/O Units is 80 W per block.

**1,2,3...**

1. Calculate the power consumption of all of the SmartSlice I/O Units connected to the PROFIBUS Communication Unit. Refer to the *GRT1 Series SmartSlice I/O Units Operation Manual (W455)* for the power value for each SmartSlice I/O Unit.
2. If the power consumption exceeds 80 W, mount a Right Turnback Unit (GRT1-TBR) on the SmartSlice I/O Unit at the point where the power consumption is less than 80 W.
3. Connect the 24 VDC Unit power supply to the Left Turnback Unit (GRT1-TBL).

##### Note

1. The GRT1-TBL is equipped with separate power supply terminals for the Unit power supply and I/O power supply.
2. When dividing the power supply, always wire (supply) the power from the same power supply (Refer to the *Wiring Example*).

##### I/O Power Supply

The maximum I/O current consumption is 4 A.

**1,2,3...**

1. Calculate the total current consumption used by all external I/O of the connected SmartSlice I/O Units (including other Units like Turnback Units). Refer to the *GRT1 Series SmartSlice I/O Units Operation Manual (W455)* for the current value for each SmartSlice I/O Unit.
2. If the current consumption exceeds 4 A or you want to provide separate systems for inputs and outputs, divide the SmartSlice I/O Units at the desired point with a GRT1-PD2 I/O Power Supply Unit and provide a separate external I/O power supply.
3. It is also possible to provide a separate external I/O power supply at a Left Turnback Unit (GRT1-TBL).

##### Note

1. The GRT1-TBL is equipped with separate power supply terminals for the Unit power supply and I/O power supply.
2. Always use isolated power supplies for the power supplies.
3. Power is not supplied through the GCN2-100 Turnback Cable. (Refer to the *Wiring Example*.)

**Wiring Example**

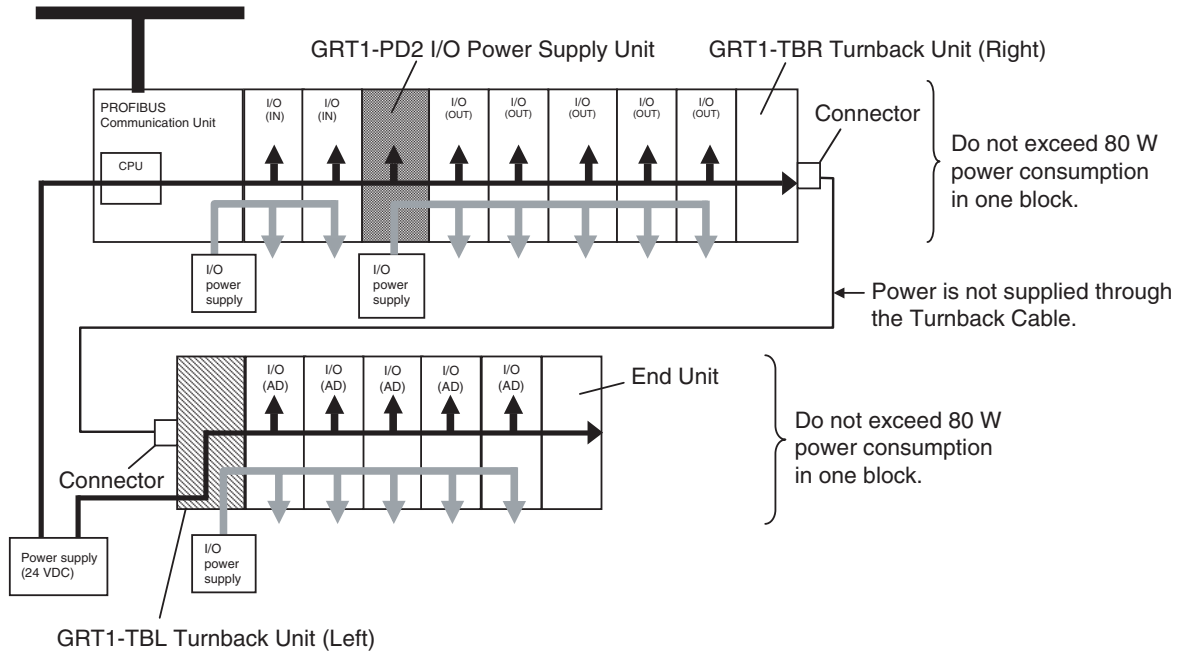

**2-3-2 Wiring Methods**

**Supplying Power to the Units**

Connect the power supply wires (24 VDC) to the PROFIBUS Communication Unit's screwless clamping power supply terminals. If pin terminals are used on the wire ends, the pin terminals can just be inserted to wire the power.

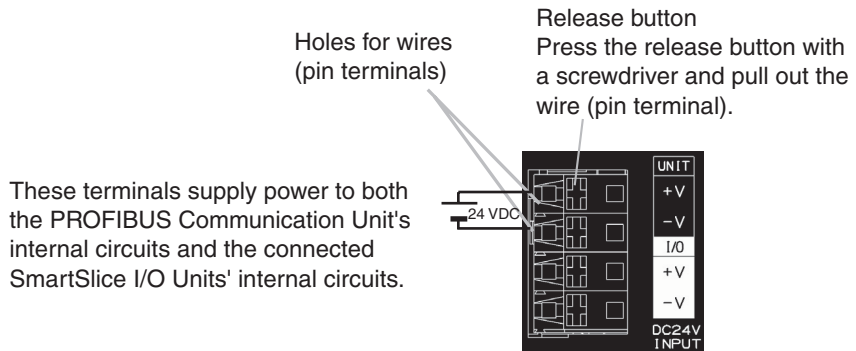

These terminals supply power to both the PROFIBUS Communication Unit's internal circuits and the connected SmartSlice I/O Units' internal circuits.

**Note** The GRT1-TBL Left Turnback Unit has the same screwless clamping power supply terminals as the PROFIBUS Communication Unit. These terminals are wired in the same way, by inserting the power supply wires.



**Supplying I/O Power**

The power supply for I/O devices is supplied through the PROFIBUS Communication Unit's screwless clamping power supply terminals. If pin terminals are used on the wire ends, the pin terminals can be inserted to wire the power.

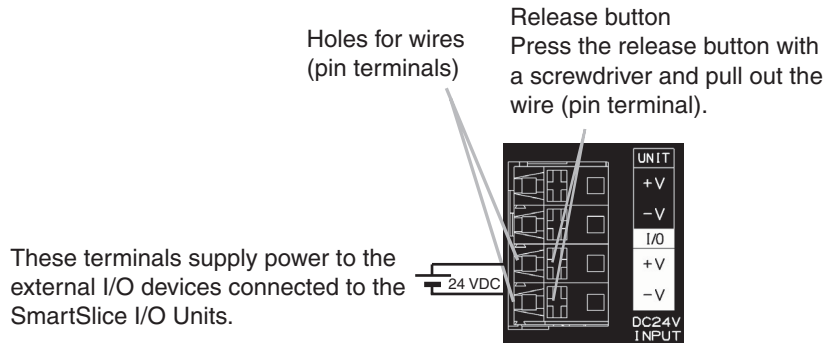

**Note** The GRT1-TBL Left Turnback Unit and GRT1-PD2 I/O Power Supply Unit have the same screwless clamping power supply terminals. These terminals are wired in the same way as the PROFIBUS Communication Unit's terminals, by inserting the power supply wires.

**Removing Wires**

To remove the wires press the release button above the terminal hole using a slotted precision screwdriver and pull out the wire.

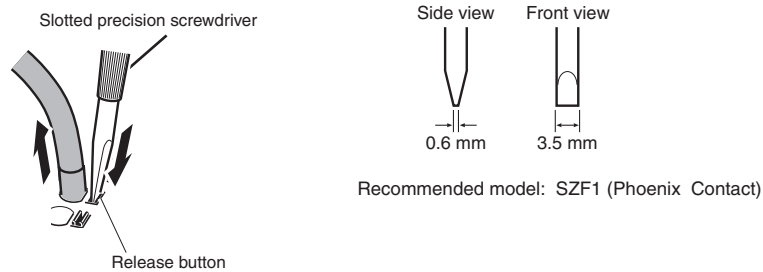

**Recommended Power Supplies**

Use a SELV power supply with over current protection. A SELV power supply has redundant or increased insulation between the I/O, an output voltage of 30 Vr.m.s and a 42.4-V peak or maximum of 60 VDC. Recommended power supply: S82K-01524 (OMRON) or S8TS-06024 (OMRON).

**Recommended Wire**

Type	Gauge
Stranded wire	20 AWG to 16 AWG (0.5 to 1.25 mm <sup>2</sup> )
Solid wire	
Pin terminal	

**Strip Length  
Pin Terminal Length**

Strip wire between 7 and 10 mm of insulation at the ends of the wires (stranded or solid wire) or use pin terminals with a pin (conductor) length of 8 to 10 mm.

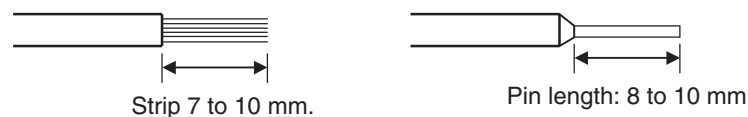

### 2-3-3 Connecting the Turnback Units

When a SmartSlice I/O System is divided into blocks to expand the system, connect a GRT1-TBR Right Turnback Unit to the GRT1-TBL Left Turnback Unit with a GCN2-100 Turnback Cable.

**Note** Power is not supplied through the GCN2-100 Turnback Cable. Always wire (supply) the power to the GRT1-TBL Left Turnback Unit from the same power supply that supplies the PROFIBUS Communication Unit.

Connect the Turnback Units with a Turnback Cable, as shown in the following diagram. A single PROFIBUS Communication Unit can be expanded with up to two additional blocks, connected with two Turnback Cables (2 m total).

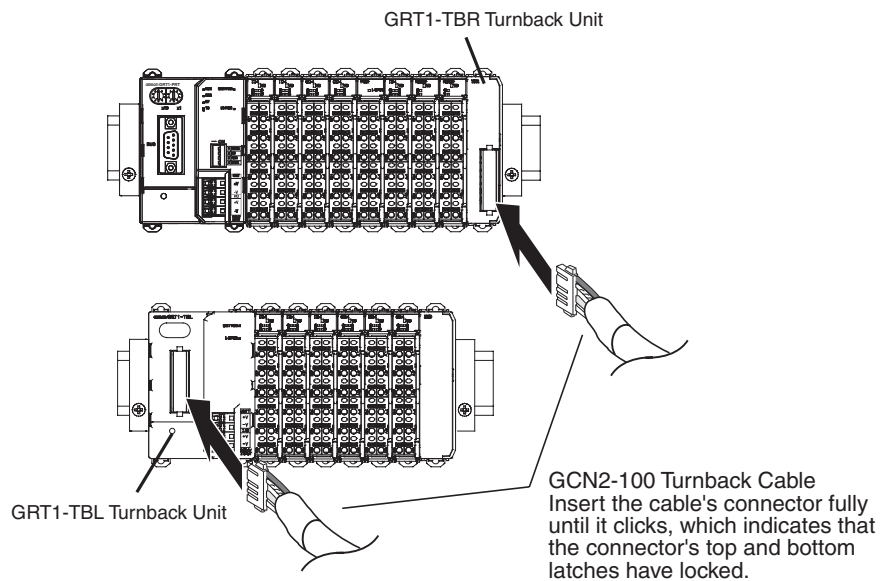

## 2-4 Setting up a PROFIBUS Network

### 2-4-1 Network Structure

**Communication Medium** The PROFIBUS standard defines the use of EIA RS-485 as the main communication transport medium. The PROFIBUS DP Master Unit is designed to interface directly to this type of medium. This section will discuss the setup of networks based on this medium.

**Note** The other communication medium specified for PROFIBUS is optical fibre. The PROFIBUS DP Master Units does not provide a direct interface to this type of medium. However, by using third party couplers an interface between EIA RS-485 and optical fibre networks can be made.

**Linear Bus Topology** PROFIBUS DP defines the use of the Linear Bus Network Topology. The Bus must be terminated at both ends, and must not contain network branches. The total cable length of the bus depends on the cable and the selected baud rate. Also, RS-485 specifies a maximum of up to 32 devices - master and slave devices - per line segment. If more than 32 devices are to be connected, or if the total length of the segment must be extended beyond its maximum, repeaters must be used to link the separate segments.

**Note** Repeaters are devices which connect two segments. They do not have a device address of their own, but they do count in the total number of devices in a segment.

**Repeaters** A maximum of up to three repeaters between two devices in a network can be used, i.e. a network can consist of up to 4 segments. The maximum number of PROFIBUS devices in such a network is then 122. The figure below shows an example of a two-segment network.

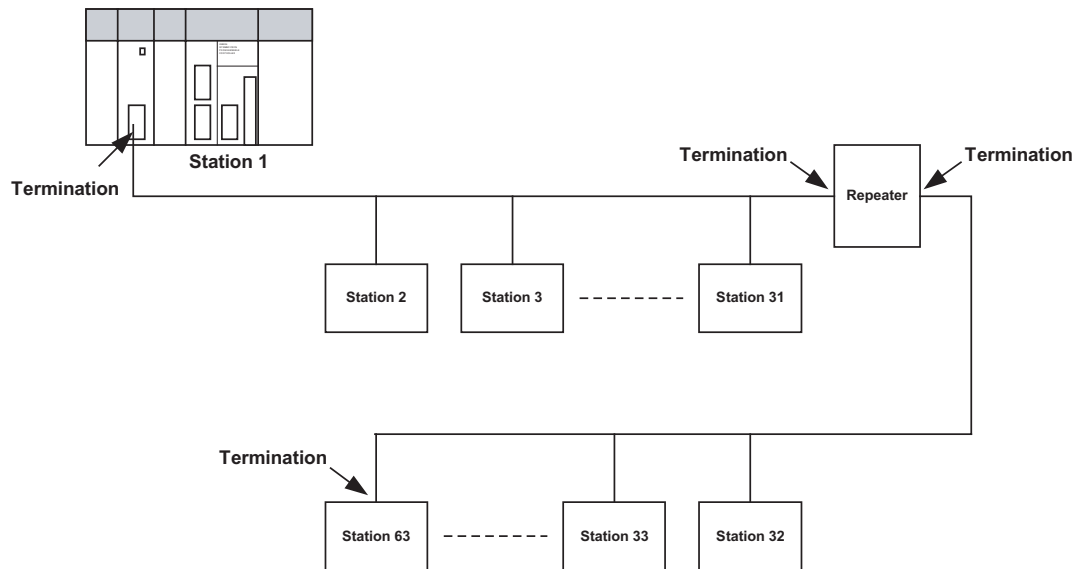

**Tree Topology** The use of repeaters allows the extension of three or more Linear Bus segments into a Tree topology. In a tree topology more than three repeaters are allowed, provided that there are no more than three repeaters between any two devices in the network. The following figure presents an example of a network with more than three segments and repeaters.

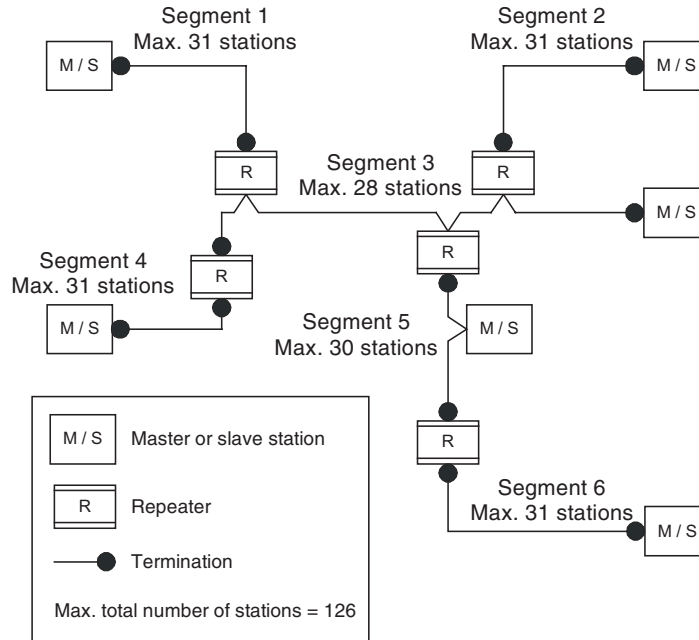

**Cable Type**

The PROFIBUS standard EN 50170 specifies Type A shielded, twisted- pair cable as the recommended cable type for use in an RS-485 based PROFIBUS network. This cable type has the following characteristics:

Characteristic	Value
Impedance	135 - 165 ohms
Capacitance per unit length	< 30 pF/m
Loop resistance	110 ohms/km
Core diameter	0.64 mm
Core cross section	0.34 mm <sup>2</sup>

**Note** The PROFIBUS standard EN 50170 also specifies a Type B cable with different cable characteristics. Use of Type B cable is no longer recommended.

**Maximum PROFIBUS Cable Length**

The transmission speed defines the maximum advised cable distance or cable segment in metres before the use of a repeater is recommended. The cable lengths specified in the following table are based on PROFIBUS type A cable.

Baud rate (kbit/s)	Distance/segment (m)	Baud rate (kbit/s)	Distance/segment (m)
9.6	1200	500	400
19.2	1200	1500	200
45.45	1200	3000	100
93.75	1200	6000	100
187.5	1000	12000	100

**Note** If network extension beyond the range of the advised cable length is required, the use of fibre optic cable to cross the larger distance should be considered.

**Stub Lines**

Passive Stub lines (branches from the main line) should be avoided for data transmission speeds of more than 500 kbit/s. Except at end devices with termination, it is recommended to always use plug connectors that permit two

data cables to be connected directly to the plug. This method allows the bus connector to be plugged and unplugged at all times without interrupting data communication between other devices.

## 2-4-2 Bus Termination

### Termination Resistors

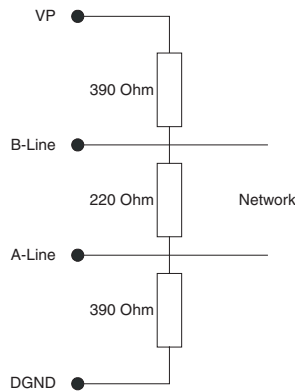

In order to minimize cable reflections and ensure a defined signal level on the data lines, the data transfer cable must be terminated at both ends with a terminating resistor combination. The bus termination diagram is shown on the left.

The bus terminator connects the two data lines via a 220 ohm resistor which, in turn, is connected to VP 5Vdc and DGND via two 390 ohm resistors. Powering the terminator resistor via VP 5V and DGND ensures a defined idle state potential on the data lines.

To ensure the correct functioning up to the highest baud rate, the bus cable must be terminated at both its ends.

A missing bus termination can cause errors during data transfer. Problems can also arise if too many bus terminators are fitted, since each bus terminator represents an electrical load and reduces the signal levels and thus the signal-to-noise ratio. Too many or missing bus terminators can also cause intermittent data transfer errors, particularly if the bus segment is operated close to the specified limits for maximum numbers of devices, maximum bus segment length and maximum data transfer rate.

### Inductors

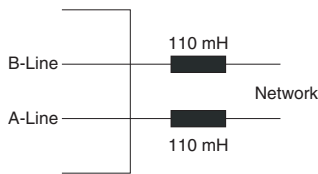

In addition to the bus termination, additional precautions must be taken to ensure proper operation at high baud rates, i.e. baud rates of 500 kbit/s and higher. Due to the capacitive load of the device and the resulting cable reflections, bus connectors must be provided with built-in series inductors, of 110 mH each, as shown in the figure on the left.

Installing the inductors applies to all devices on the network, and not only to the devices at both ends of the bus cable.

### 2-4-3 PROFIBUS Cable Connector

#### Bus Cable Connector

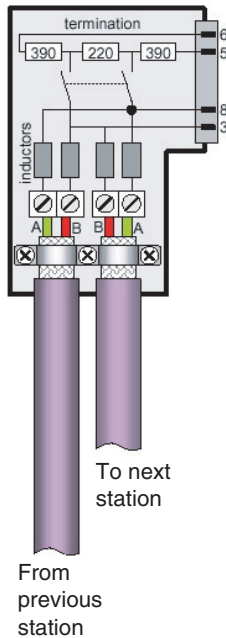

The plug connector to be used on the CS/CJ-series PROFIBUS DP Master Unit is a 9-pin male sub-D type, preferably encased in metal and having a facility to connect the shield of the cable to the case or to pin 1. The cable should be connected to the receive / transmit lines, pin 3 (B-line) and pin 8 (A-line).

The use of special PROFIBUS DP cable connectors, which are available from several manufacturers, is highly recommended. Various models are widely available, with or without the bus termination and inductors built-in. If provided in the connector, the Bus termination can often be enabled or disabled through a switch on the connector.

The special PROFIBUS DP cable connectors often provide a convenient way of connecting the cables. The figure on the left, provides an example of such a bus cable connector.

A standard 9-pin sub-D plug can only be used if the PROFIBUS DP Master Unit is not at the start or the end of a bus segment, or on a stub line at a baud rate of 500 kbit/s or less.

The two PROFIBUS data lines are designated A and B. There are no regulations on which cable core colour should be connected to which of the two data terminals on each PROFIBUS device; the sole requirement is to ensure that the same core colour is connected to the same terminal (A or B) for all devices throughout the entire system (across all devices and bus segments). The PROFIBUS Organization recommends the following rule for data line colour codes: PROFIBUS cables in general will use the colours red and green for the data lines, with the following assignment:

- Data cable wire A - green
- Data cable wire B - red

This rule applies to both the incoming and the outgoing data lines.

### 2-4-4 Shielding Precautions

#### Cable Shield Connection

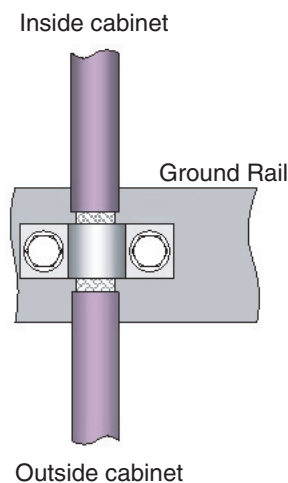

To ensure electro-magnetic compatibility (EMC), the shield of the cable should be connected to the metal case of the plug connector.

If the Unit is installed in a control cabinet, the bus cable shield should be brought into physical contact with a grounding rail using a grounding clamp or similar device. The cable shield should continue in the cabinet right up to the PROFIBUS device.

Ensure that the PLC and the control cabinet in which it is mounted have the same ground potential by providing a large-area metallic contact to ground, e.g. galvanized steel to ensure a good electrical connection. Grounding rails should not be attached to painted surfaces.

For further information regarding PROFIBUS network installation, please refer to "Installation Guideline for PROFIBUS DP/FMS" (PNO Order No. 2.112), which is available at every regional PROFIBUS Organization. The information covers:

- Commissioning of PROFIBUS equipment.
- Testing the PROFIBUS cable and bus connectors.
- Determining loop resistance.
- Testing for correct bus termination.
- Determining the segment length and cable route.

## 2-5 Installation of Configuration Software

In order to operate the GRT1-PRT and the SmartSlice I/O system the PROFIBUS DP Master needs to be configured for communication with the GRT1-PRT. For this purpose OMRON provides the GRT1-PRT DTM via the OMRON web site <http://www.omron-industrial.com/>

After installation the DTM will run in the OMRON Cx-Profibus FDT Container, allowing the user to setup the I/O configuration and setting the parameters of both the GRT1-PRT as well as individual SmartSlice I/O Units.

**Note** To fully utilize the features of the GRT1-PRT and the SmartSlice I/O system, a PROFIBUS DP-V1 Class 2 capable Master Unit and DTM are required. The OMRON CS1/CJ1W-PRM21 Master units provide this functionality as of version 3.0.

### 2-5-1 Installation Requirements

The following are the minimum requirements for a PC to install the GRT1-PRT DTM configuration software:

- PC Pentium III or higher, 500 MHz minimum
- Operating System: Windows 2000 SP2 / Windows NT 4.0, SP6 / Windows XP
- RAM: 256 MB minimum
- Hard disk space: 256 MB minimum
- Graphics resolution: 1024 x 768 pixels minimum
- Installed FDT Container software, e.g. OMRON's Cx-Profibus.

### 2-5-2 Installation Procedure

#### DTM Installation

This section explains how to install the Cx-Profibus Configuration software and its components for the PROFIBUS Master Unit.

- 1,2,3...**
1. Exit all other Windows-based programs.
  2. Double-click the file **GRT1PRT\_SmartSlice\_IO\_Coupler\_Setup.exe**.  
The setup program for the GRT1-PRT DTM will start. A progress dialog window is displayed, indicating progress of the setup as the program is loaded.
  3. The setup program will check the version of the CS1/CJ1W-PRM21 PROFIBUS Master DTM installed. Running the GRT1-PRT requires a Master DTM version of 0.7.0.0 or higher. If this version is not installed, the following warning screen will pop up.

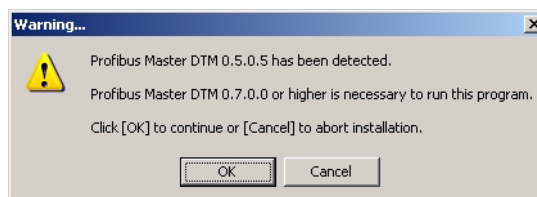

The appropriate version of the CS1/CJ1W-PRM21 Master DTM is available through OMRON's web site. Pressing the **OK** button, will continue with installation.

- The user is then prompted to specify the installation directory.

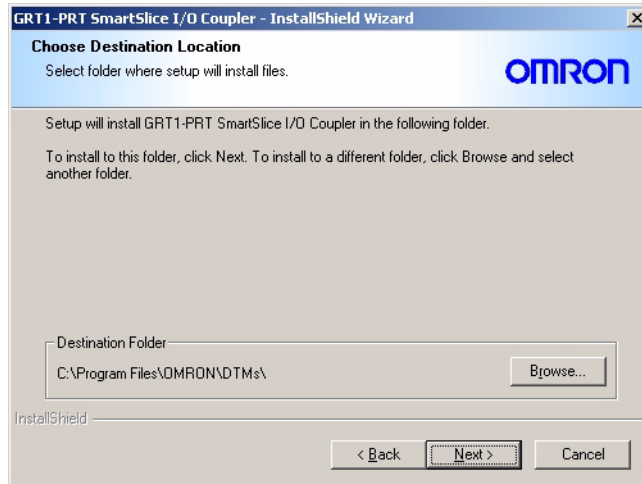

- Pressing the **Next** button will summarize the settings after which installation will commence.
- When done, the installation program will notify the user of its completion.

**Updating the Device Catalogue**

After installation of the GRT1-PRT DTM the Device Catalogue in the FDT Container needs to be updated, to show the new GRT1-PRT DTM in the list of available devices. For Cx-Profibus the following procedure applies

**1,2,3...**

- Open the Device Catalogue window in Cx-Profibus.
- Press the Update button to initiate the update sequence.

After updating, the GRT1-PRT DTM will be shown in the list of available devices. It can now be used to setup a PROFIBUS network and configure the Master Unit.

**Note** In case the required CS1/CJ1W-PRM21 PROFIBUS Master DTM has not been installed, this needs to be done first to allow the full features of the GRT1-PRT DTM to be used.

**2-5-3 GRT1-PRT GSD File**

Apart from the GRT1-PRT DTM, OMRON provides a GSD file to allow configuration of third-party PROFIBUS Master Units, which do not provide an FDT Container. The GSD file - OC\_09FE.gsd - is available through the OMRON Web site: <http://www.omron-industrial.com/>

Section 3-3-3 *Setup Using the GSD File* discusses configuration of the PROFIBUS DP Master using this GSD file.

**Note** Using the GSD file for configuration allows the user to configure the Master Unit for I/O data exchange with the GRT1-PRT and the SmartSlice I/O System. It does not however, provide the acyclic messaging capabilities to access parameters and status information in individual SmartSlice I/O Units. The GRT1-PRT DTM does provide this capability.

The next section will discuss the features of the GRT1-PRT in detail as well as how to setup, configure and operate the SmartSlice I/O System in a PROFIBUS network.





# SECTION 3

## Setup and Operation

This section describes the operational aspects of the GRT1-PRT and the SmartSlice I/O System. It first discusses the operational features which can be used, prior to describing how to setup the system and how to operate and monitor it on a PROFIBUS network.

3-1	Station Address Settings and I/O Allocation . . . . .	32
3-1-1	Setting the PROFIBUS Station Address. . . . .	32
3-1-2	SmartSlice I/O Unit Number Allocation . . . . .	32
3-1-3	SmartSlice I/O Allocation to the GRT1-PRT Unit . . . . .	33
3-2	Unit Functions. . . . .	36
3-2-1	Table Registration Function . . . . .	36
3-2-2	Backup Function. . . . .	38
3-2-3	Automatic Restore Function. . . . .	38
3-2-4	Online Replacement Function . . . . .	40
3-2-5	I/O Communication Error History Monitor . . . . .	41
3-3	Setup the GRT1-PRT Configuration . . . . .	42
3-3-1	Defining the PROFIBUS Network . . . . .	42
3-3-2	Setup Using the DTM. . . . .	43
3-3-3	Setup Using the GSD File. . . . .	48
3-3-4	Mapping I/O Data. . . . .	51
3-4	Operating the Network . . . . .	52
3-4-1	Monitoring the GRT1-PRT. . . . .	52
3-4-2	Monitoring the SmartSlice I/O System. . . . .	54
3-5	Remote Communication Characteristics. . . . .	55
3-5-1	I/O Communication Characteristics . . . . .	55
3-5-2	Message Communication Characteristics. . . . .	58

## 3-1 Station Address Settings and I/O Allocation

In order to identify the PROFIBUS Communication Unit on the PROFIBUS network, it needs to be assigned a unique station address. Using this address the PROFIBUS Master Unit can transfer parameter settings and exchange I/O data. The PROFIBUS station address is assigned using the rotary switches on the front of the Unit.

Similarly, the individual SmartSlice I/O Units need a unique address to identify each of them to the GRT1-PRT Unit. Contrary to the GRT1-PRT Unit, the individual SmartSlice I/O Unit addresses are assigned automatically at startup.

### 3-1-1 Setting the PROFIBUS Station Address

The station address of the PROFIBUS Communication Unit Slave is set with the rotary switches on the front of the PROFIBUS Communication Unit.

#### PROFIBUS Station Address Setting

The left rotary switch sets the ten's digit, and the right rotary switch sets the one's digit.



PROFIBUS station address setting

×10    ×1

The valid address range is 00 to 99 can be set as long as this number is not set on another station (Master or Slave) in the network. However, the following must be observed.

**Caution** In the messaging services the address 00 is reserved. This means that when selecting the GRT1-PRT Station address to be 0, it will be able to exchange I/O data over PROFIBUS, but it will not be possible to upload / download parameters or status information.

- Note**
1. Always turn OFF the PROFIBUS communication power supply and PROFIBUS Communication Unit's power supply before setting the station address.
  2. The factory default setting for the station address is 00.
  3. If the station address is duplicated on another station, communication will not be achieved.

### 3-1-2 SmartSlice I/O Unit Number Allocation

The SmartSlice I/O Unit numbers are used to identify the individual I/O Units in the SmartSlice system. These unit numbers are assigned automatically at startup, when the power is turned ON. The numbering starts from #1 and runs from left to right. It is not necessary for the user to set these numbers.

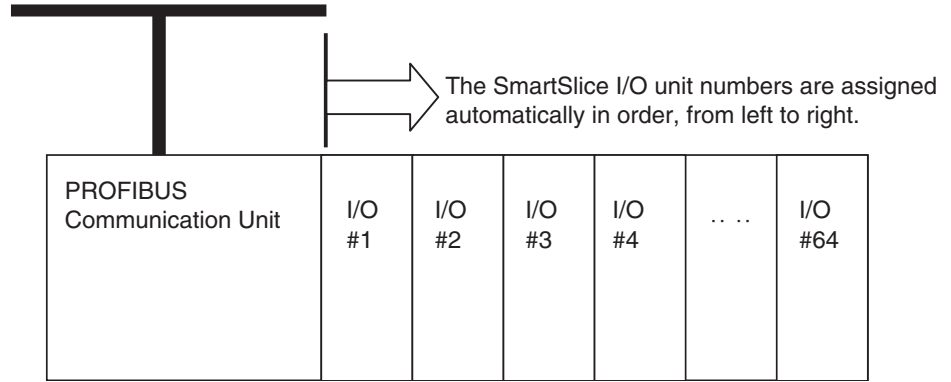

1. The presence of Turnback units and cables does not influence the automatic allocation of Unit numbers.
2. The unit numbers allocated automatically to the SmartSlice I/O Units are unrelated to the PROFIBUS station address set with the rotary switches.

### 3-1-3 SmartSlice I/O Allocation to the GRT1-PRT Unit

The SmartSlice I/O Units' I/O data is mapped in the I/O memory of the GRT1-PRT, from which it is transferred to the PROFIBUS Master unit. This allocation is done automatically and determined by the SmartSlice I/O Unit's type. The figure below shows this mapping.

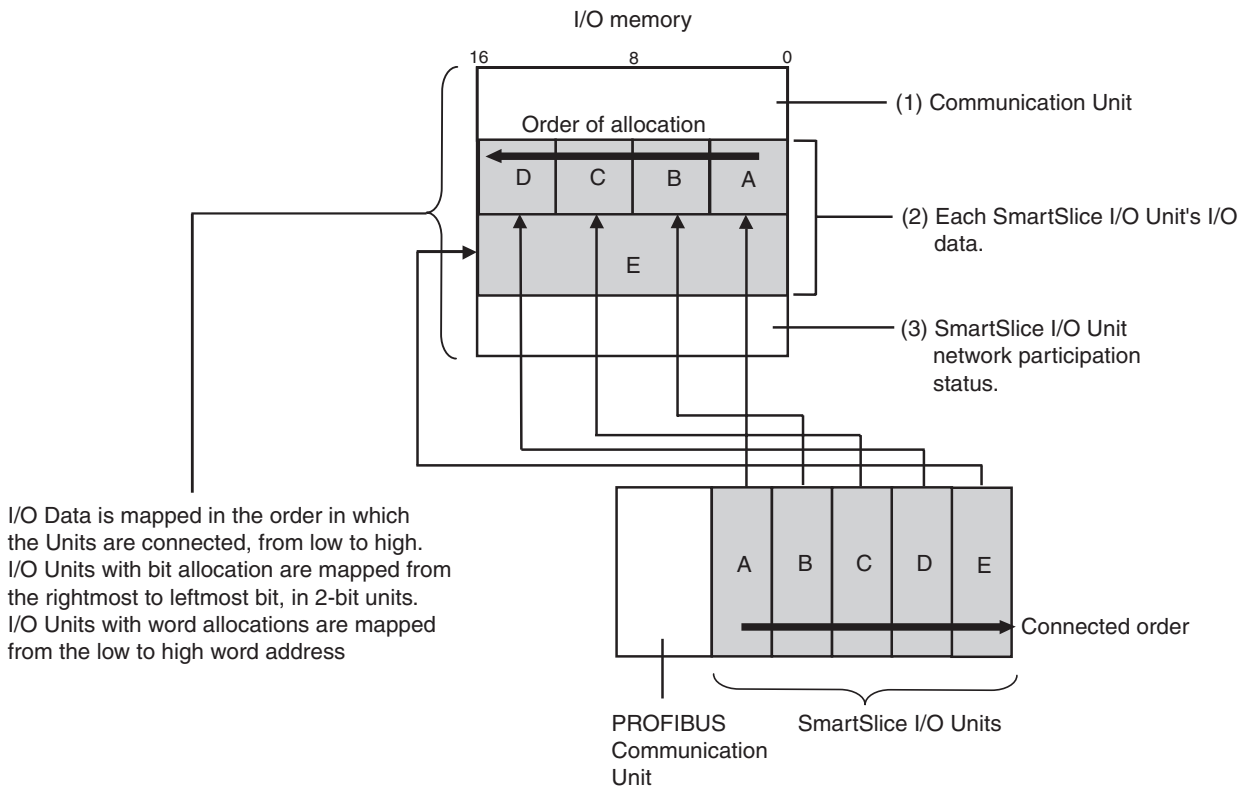

- Note**
1. I/O data is mapped in the order of SmartSlice I/O Unit connection to the PROFIBUS Communication Unit, regardless of the I/O Units' models.

2. One block of mapped Output data (from the Master Unit) and one block of mapped Input data are maintained in the GRT1-PRT and transferred to/from the Master Unit.
3. The first Input data word always contains the SmartSlice I/O Status word.
4. Bit-sized SmartSlice I/O Units, e.g. GRT1-ID4, GRT1-OD4 are grouped together in words.
5. Word sized SmartSlice I/O Units, e.g. GRT1-AD2, GRT1-DA2V are mapped to one or more words.
6. Total size of mapped I/O data can be 64 words output and 64 words input.

**I/O Allocation Example**

I/O data is mapped to the GRT1-PRT Units I/O data blocks in the same order the SmartSlice I/O Units are connected to the PROFIBUS Communication Unit, regardless of the I/O Units' models.

The example below shows the I/O data mapping to the Input / Output blocks.

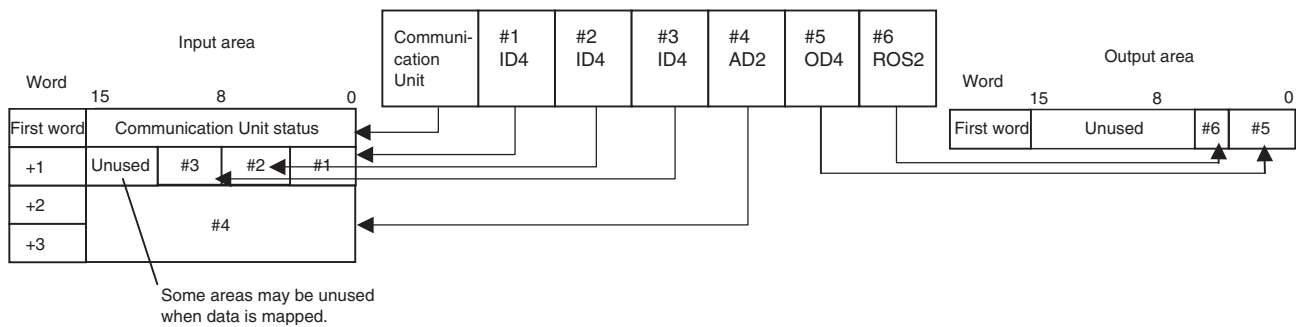

**Note** I/O Units with bit allocation (e.g. GRT1-ID4/OD4) allocate data in 2-bit units. I/O Units with word allocation (such as the GRT1-AD2) are allocated data in 1-word units. The following example shows the mapping of Output Units.

SmartSlice I/O Unit configuration

Communications Unit	#1 OD4	#2 OD4	#3 OD4	#4 ROS2	#5 OD4	#6 DA2V
---------------------	--------	--------	--------	---------	--------	---------

↓

Data is allocated in 2-bit units to I/O Units which require 4 bits, There may be unused areas as shown in the following table.

Word	15	8	0
+0	#5	#4	#3 #2 #1
+1	Unused		#5
+2	#6		
+3			

**Allocated Data Size**

Data type	Data size
I/O data (input and output)	64 input words max. or 64 output words max. GRT1-ID4(-1) / GRT1-OD4(-1): 4 bits per Unit. GRT1-ROS2: 2 bits. GRT1-AD2: 1, 2 or 3 words I/O data. GRT1-DA2V/DA2C: 2 words output data.
Communication Unit status flags	1 word
SmartSlice I/O Unit communication participating/withdrawn flags	Participating flags: 4 words Withdrawn flags: 4 words Total: 8 words
I/O data (inputs) + Communication Unit status flags	Amount of I/O data being used + 1 word

**Status Flags**

There are two types of status flags

- Communication Unit's status flags, transferred with the Input data.
- I/O Unit's communication participating/withdrawn flags, obtained through messaging services.

**Communication Unit's Status Flags**

These flags can be used to monitor the status of the connection between the GRT1-PRT and the SmartSlice I/O Units as well as the status of the SmartSlice I/O Units themselves. The status flags take up 1 word and the information is transferred to the Master as part of the Input data. The table below defines the individual bits in the Status word..

Bit	Content	Description
0	SmartSlice I/O Bus Communication Error Flag	Monitors the status of SmartSlice I/O System communication.
1	Reserved	---
2	SmartSlice I/O Unit Warning Flag 0: Normal 1: Error detected	Indicates a major SmartSlice I/O Unit error. This flag goes ON when there is an error in any one of the connected SmartSlice I/O Units.
3	Reserved	---
4	SmartSlice I/O Unit Alarm Flag 0: Normal 1: Error detected	Indicates a minor SmartSlice I/O Unit error. This flag goes ON when there is an error in any one of the connected SmartSlice I/O Units.
5~11	Reserved	---
12	Unit Maintenance Flag 0: Normal 1: Error (monitor value reached)	Monitors the Unit's operating time the power ON time threshold set with the Unit power ON time monitor function.
13	Automatic Restore Monitor Flag 0: Restore successful 1: Restore failed	Indicates whether or not the automatic parameter restoration to the SmartSlice I/O Units was completed successfully.
14	Communication Unit Error Flag 0: Normal 1: Error occurred	This is the overall Unit status flag. This flag will be ON if any one of the other flags (bits 0 to 13) is ON.
15	I/O Refreshing Flag 0: I/O communication stopped 1: I/O communication normal	Indicates whether I/O data is being exchanged normally.

### 3-2 Unit Functions

The following table lists the PROFIBUS Communication Unit's functions.

Function name	Summary	Setting/monitoring method
Table registration	Reads the configuration of the SmartSlice I/O Units connected to the Communication Unit and registers that information in a table.	Set with DIP switch.
Backup	Records the parameter data of all connected I/O Units in the Communication Unit.	Set with DIP switch.
Automatic restore	Automatically downloads the backed-up parameter data to the appropriate Unit.	Set with DIP switch.
Online replacement	I/O Units can be replaced without turning the power OFF.	No setting required.
I/O communication error history	A history of communication errors with connected I/O Units can be collected in the Communication Unit.	Set/read with Configurator or explicit message.

#### 3-2-1 Table Registration Function

##### Function Overview

This function registers the configuration of the SmartSlice I/O Units connected to the PROFIBUS Communication Unit in a table within the Unit, to allow the registered I/O table to be compared automatically with the actual configuration each time the power is turned ON. The configuration is registered by turning ON (OFF to ON) DIP switch 1 of the PROFIBUS Communication Unit while the SmartSlice I/O Units' power supply is ON. The registered table is enabled if DIP switch 1 is ON when the power is turned ON. If DIP switch 1 is OFF when the power is turned ON, the registered table is disabled and the Communication Unit will automatically detect the actual I/O configuration and start communication.

##### Creating a New Registration Table

The SmartSlice I/O System's actual I/O configuration can be read and registered in the table just by turning DIP switch pin 1 (REGS) from OFF to ON while the PROFIBUS Communication Unit's power supply is ON. If the registration table is being refreshed, the old registration table will be erased.

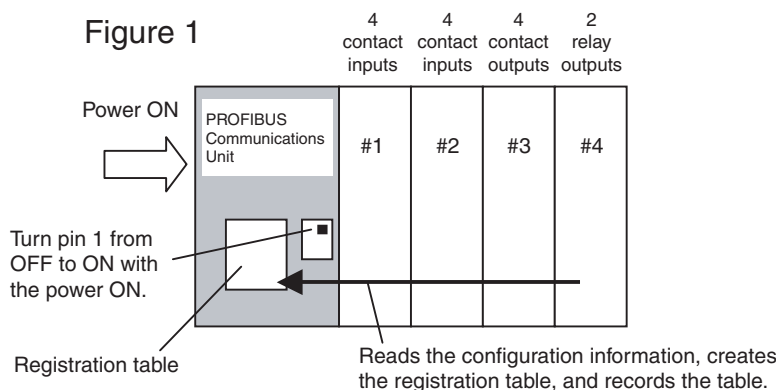

**Note** The configuration information records the order that the SmartSlice I/O Units are connected and the I/O size (input or output, number of bits) of each SmartSlice I/O Unit. The I/O Unit model numbers are not recorded.

**Comparison with the Registered Table**

When DIP switch pin 1 (REGS) is ON and an I/O configuration table has been registered in the Communication Unit, the actual I/O configuration is automatically compared to the registered table when the power is turned ON. A verification error will occur if a registered I/O Unit cannot join I/O communication or an unregistered I/O Unit is detected.

In case of verification errors, the affected SmartSlice I/O Units will not participate in I/O communication. I/O communication will start with the other SmartSlice I/O Units.

**Example of Comparison between Figure 1 and Figure 2**

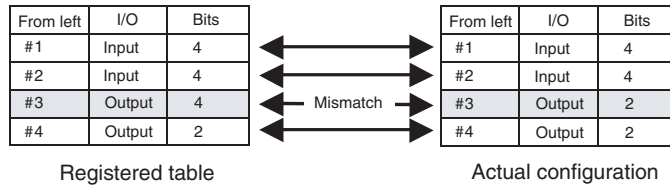
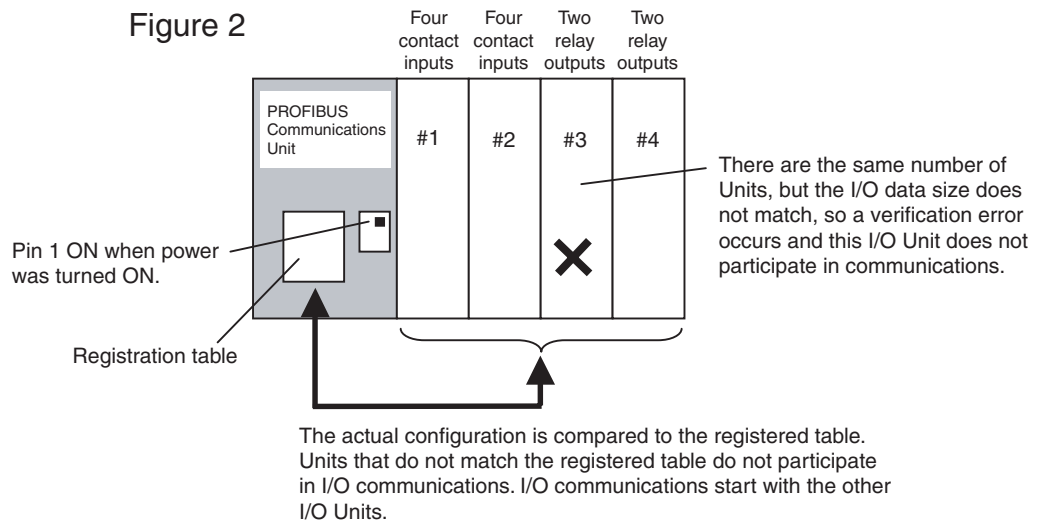

Figure 2



- Note**
1. Register the I/O configuration table when all of the SmartSlice I/O Units are communicating, i.e., when the PROFIBUS Communication Unit's TS indicator is lit green.
  2. A mismatch (verification error) with the registered table is indicated at the PROFIBUS Communication Unit's TS indicator (flashing red). The error details can be retrieved using the GRT1-PRT DTM. Also, the error history can be read with an explicit message command.



## 3-2-2 Backup Function

### Function Overview

The backup function records the parameter data of all SmartSlice I/O Units connected to the PROFIBUS Communication Unit. The parameter data recorded in the Communication Unit can be restored to the SmartSlice I/O Units later with the automatic restore function when a SmartSlice I/O Unit has been replaced.

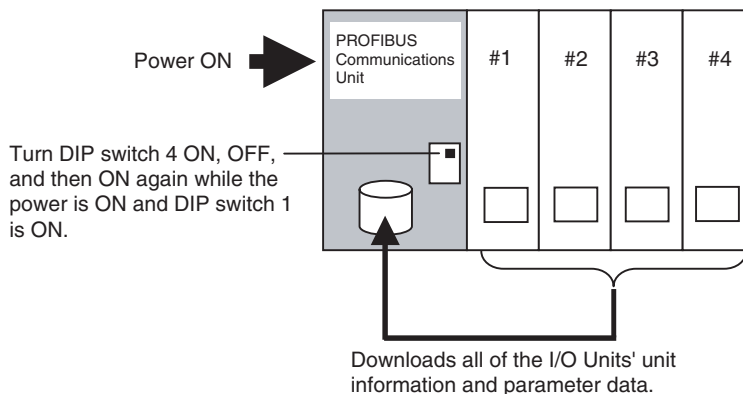

### Backup Procedure

- 1,2,3...**
1. Verify that the power is ON, DIP switch 1 (REGS) is ON, and all of the SmartSlice I/O Units are participating in I/O communication.
  2. Turn DIP switch 4 (BACK) ON, then OFF, and then ON again within 3 s to start the back up.
  3. While the data is being backed up, the PROFIBUS Communication Unit's TS indicator will flash green every 0.5 s. The TS indicator will stop flashing (not lit) when the backup is completed. If the restore operation fails, the TS indicator will be lit red for 2 s.

- Note**
1. Do not turn OFF the power supply or reset the Configurator while data is being backed up. The data will not be backed up properly if the power is turned OFF.
  2. The backup data will be erased along with the registered I/O configuration table if DIP switch pin 1 (REGS) is turned OFF.
  3. Backing up the parameter data is recommended to allow easy replacement of faulty Units in the future.

## 3-2-3 Automatic Restore Function

### Function Overview

When a SmartSlice I/O Unit has been replaced, this function will automatically download (restore) SmartSlice I/O Unit parameter data that was previously backed up in the PROFIBUS Communication Unit. The following conditions are required to execute the automatic restore function:

- DIP switch 1 (REGS) was ON when the power was turned ON, and the registered table is therefore enabled.
- DIP switch 3 (ADR) was ON when the power was turned ON, and the automatic restore function is therefore enabled.
- Parameter data has been backed up in the PROFIBUS Communication Unit.

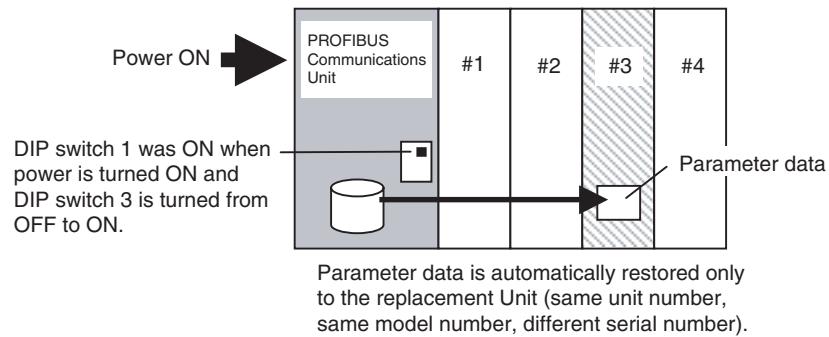

### Preparing Data Restore

- 1,2,3...**
1. Create backup data in the Communication Unit with the backup function. For details, see 3-2-2 *Backup Function*.
  2. Turn ON DIP switch 3 (ADR).

### Replacing a Unit

- 1,2,3...**
1. Turn OFF the SmartSlice I/O System's power supply and the I/O power supply.
  2. Release the locks on the front of the SmartSlice I/O Unit that must be replaced and remove the terminal block. The wiring can remain connected.
  3. Remove the main block of the SmartSlice I/O Unit and replace it with a new SmartSlice I/O Unit of the same type.
  4. Mount the terminal block that was removed in step 2 and latch the lock that was released.
  5. When the power is turned ON again, the Communication Unit will automatically detect the Unit that was replaced and download the backup data. The SmartSlice I/O Unit's TS indicator will indicate the results of the restore operation.
    - If the download was successful, the Unit will be reset automatically and join I/O communication normally. The I/O Unit's TS indicator will be lit green.
    - If the download failed, the I/O Unit's TS indicator will flash red.
    - If the connected Unit is the wrong model, the I/O Unit's TS indicator will be lit red.

- Note**
1. Do not turn OFF the power supply or reset the PROFIBUS Communication Unit while data is being restored. The data will not be restored properly if the power is turned OFF.
  2. When an I/O Unit has been replaced with the power ON and the new I/O Unit joins I/O communication, the new Unit will be compared to the previous one and the parameter data restore operation will start automatically. While data is being restored, the PROFIBUS Communication Unit's TS indicator will flash green every 0.5 s. The TS indicator will stop flashing (not lit) when the restore operation is completed. If the restore operation fails, the Automatic Restore Monitor Flag (bit 13 of the Communication Unit status flags) will be turned ON and the Communication Unit's TS indicator will be lit red for 2 s.

### 3-2-4 Online Replacement Function

#### Function Overview

When one of the SmartSlice I/O Units connected to the PROFIBUS Communication Unit must be replaced, the Unit can be replaced without turning OFF the power. The Units can be replaced online because the SmartSlice I/O Units are made up of 3 blocks: the base block, main block, and terminal block. When replacing a SmartSlice I/O Unit, leave just the base block connected and replace the main block. I/O communication will continue with the other I/O Units even while the problem Unit is being removed and replaced.

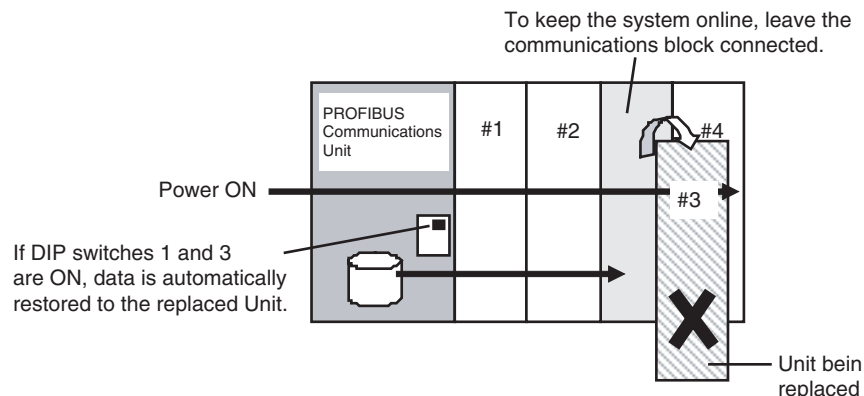

#### Replacing a Unit

**1,2,3...**

1. Turn OFF the I/O power supply of the I/O Unit being replaced.
2. Release the locks on the front of the I/O Unit that must be replaced and remove the terminal block. The wiring can remain connected.
3. Remove the main block of the SmartSlice I/O Unit and replace it with a new I/O Unit of the same type.
4. Mount the terminal block that was removed in step 2 and latch the hook that was released.
5. Turn ON the I/O power supply.

#### Note

1. When a Unit withdraws from I/O communication during replacement, the corresponding SmartSlice I/O Unit Communication Withdrawn Flag will go ON and the PROFIBUS Communication Unit's TS indicator will flash red.
2. Before using the automatic restore function, the preparation for automatic restoration (creating backup data and turning ON DIP switch 3) must be completed. See 3-2-3 *Automatic Restore Function* for details.
3. Always turn OFF the I/O Unit's I/O power supply before replacement in order to prevent false output signals, false input signals, and electrical shocks. In addition, if external power is supplied to the terminal block for a Unit such as a Relay Output Unit, turn OFF that power supply before replacing the Unit.
4. Only replace one I/O Unit at a time.
5. Always replace the I/O Unit with the same model of I/O Unit. If a Unit is replaced with a different model, there may be unexpected outputs and the restore operation may not be completed properly.
6. If the base block is faulty or damaged, turn OFF the power supply and replace the entire Unit. Even in this case, the I/O Unit's parameter data will be restored automatically if the automatic restore function is enabled when the power is turned ON.

### 3-2-5 I/O Communication Error History Monitor

**Function Overview**

The PROFIBUS Communication Unit can record the 64 most recent internal SmartSlice Communication Unit errors in the Unit's error history. When more than 64 errors occur, the oldest entry is deleted to make space for the newest error entry. The communication error history can be read from the GRT1-PRT DTM or via messaging services.

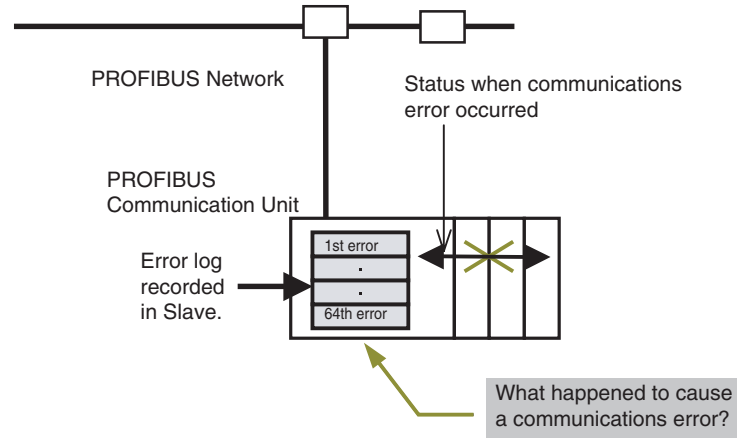

**Checking Using the GRT1-PRT DTM**

To check the internal communication error history using the GRT1-PRT DTM and OMRON's FDT Container Cx-Profibus, perform the following actions.

1,2,3...

1. Turn ON the PROFIBUS Communication Unit's power supply.
2. In Cx-Profibus right click the mouse over the icon of the GRT1-PRT, and select **Diagnosis**.
3. Select the **I/O Unit Error History** Tab in the Diagnosis Window. The communication error history for the most recent errors that occurred will be displayed, as shown in the following window. To display the most recent error history, click the **Update** Button.

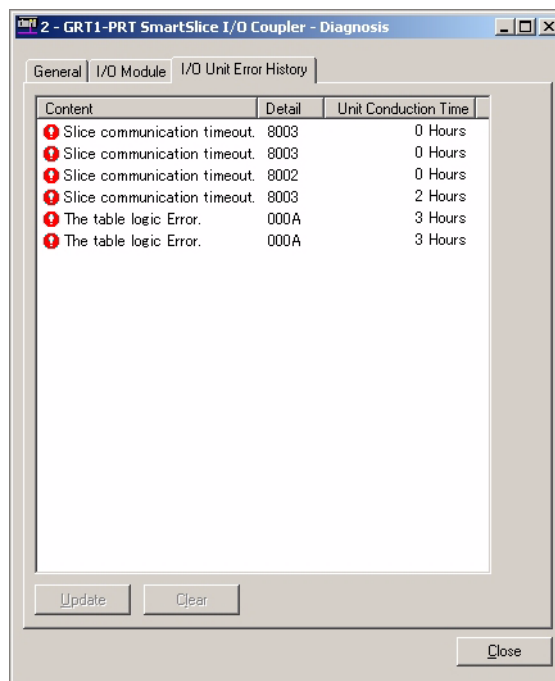

**Note** The method described is also available in third party FDT Containers, although slightly different terminology may be used in the menus.

## 3-3 Setup the GRT1-PRT Configuration

Setting up a PROFIBUS Master Unit to exchange parameters and I/O data with the GRT1-PRT and the SmartSlice I/O System involves defining the I/O configuration to the Master Unit and to set parameters needed at run-time. Refer to *Appendix A PROFIBUS Technology* for more information on PROFIBUS network commissioning.

This section discusses the methods of configuration.

### 3-3-1 Defining the PROFIBUS Network

Defining the PROFIBUS network in the Cx-Profibus FDT Container, starts with defining the PROFIBUS Master Unit and assigning the slave devices to it. Defining and assigning devices can be achieved using drag & drop from the Cx-Profibus Device Catalogue. Refer to the *CS/CJ-series PROFIBUS DP Master Units Operation Manual (W409)* for more information on how to assemble a network. The figure below shows Cx-Profibus with an assembled network in the left window pane and the Device Catalogue opened in the main window pane.

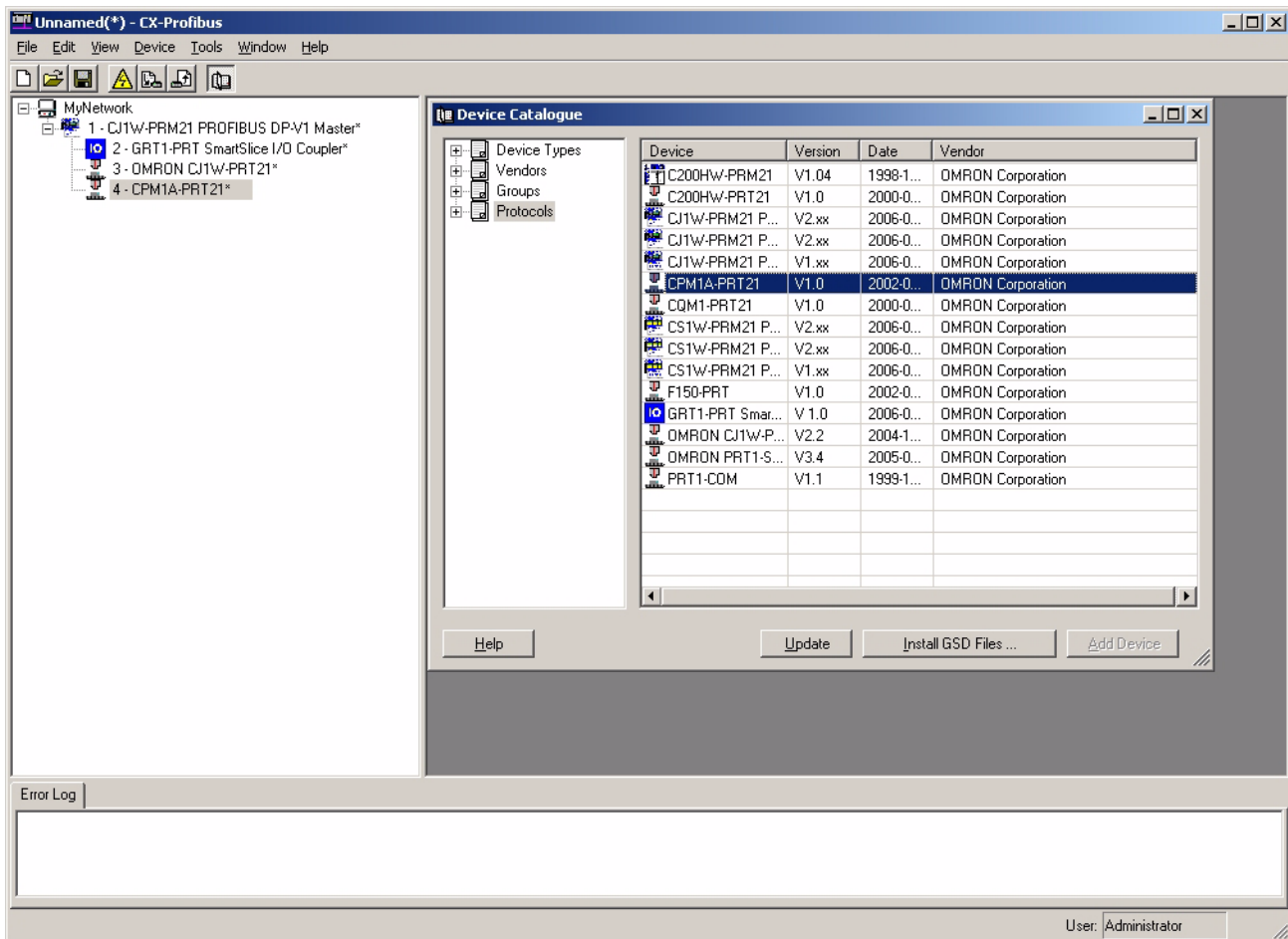

To define the I/O Configuration of the GRT1-PRT SmartSlice Communication Unit, double-click the device in the Network view using the left mouse button. A separate configuration window will pop up, which is described in the next section.

### 3-3-2 Setup Using the DTM

GRT1-PRT DTM window which pops up after double-clicking the GRT1-PRT entry in the Network View is shown below.

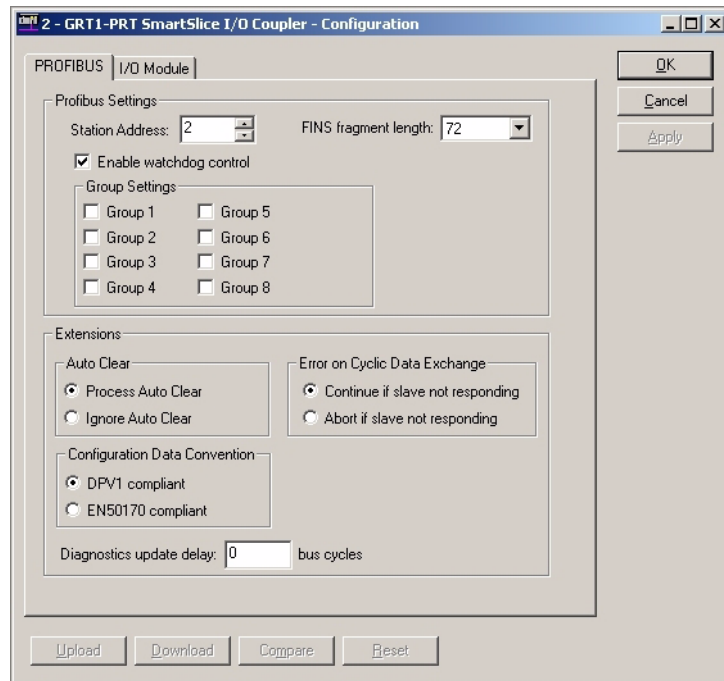

**Note** The buttons on the bottom will be enabled only when the DTM is on-line.

#### **Parameter Area Tab**

The Parameter Area Tab, shown above, defines the parameter settings for the GRT1-PRT. In this Tab are two distinct sub areas of parameters.

- PROFIBUS Settings Box
- Extensions Box

#### **PROFIBUS Settings Box**

The PROFIBUS Settings Box contains

- the Station address,
- the Watchdog Control settings,
- the Group Selection
- the FINS Fragment length.

#### **Station Address Setting**

The Station Address is automatically assigned by the Master DTM. Only change this setting if the physical device has a different address from the one assigned by the Master DTM. The allowable range is 00 to 99.

**⚠ Caution** It is recommended not to use address 00, since in that case the messaging services will not work. Address 00 is reserved for Master Units.

#### **Watchdog Control Setting**

The Watchdog Control check box allows Enable/Disable of the Communication watchdog. If the Watchdog has been enabled, the GRT1-PRT will revert to a safe state, in case the PROFIBUS communication stops. The Watchdog will be Enabled by default, and it is recommended to leave it Enabled.

**Note** The Watchdog timeout Interval is defined by the PROFIBUS Master DTM and depends on the Bus parameters as well as on the total amount of Slave devices on the network.

**Group Setting**

The Group Setting selects to which of 8 groups the GRT1-PRT will belong. This setting allows the user to control input and output data on specific groups of devices using the broadcast command. Refer to Appendix A-4 *Bus Access Protocol* for more information on the broadcast command.

**FINS Fragment Length Setting**

The FINS Fragment Length determines the maximum fragment size used on messaging services, when being wrapped in to PROFIBUS messages. The default setting is 72 bytes. It is recommended not to change it.

**Extensions Box**

The Extensions Box contains a number of settings, which define additional behaviour of the PROFIBUS Master Unit with respect to the GRT1-PRT. This specific behaviour is defined in the PROFIBUS DP extensions standard (PROFIBUS DP-V1), but it does not necessarily require PROFIBUS DP-V1 capabilities from the PROFIBUS Master Units.

**Auto-Clear Processing**

The Auto-Clear processing box defines whether or not the PROFIBUS Master Unit should ignore a failure of the GRT1-PRT, when Auto-CLEAR has been enabled in the Master Unit (Refer to Appendix A-6 *Protection Mechanisms* for more information on Auto-CLEAR). When Ignore Auto-CLEAR has been selected, a failure of the GRT1-PRT (i.e. it requests new parameters, or fails to respond) will not activate the Auto-CLEAR mode. The Master Unit will however, service the slave device.

This feature can be used in case failure during operation, does not necessitate to switch the entire network to Auto-CLEAR mode.

Control	Description
Process Auto-CLEAR	When Auto-CLEAR has been enabled in the PROFIBUS Master Unit, a failure of the GRT1-PRT will cause an Auto-CLEAR event.
Ignore Auto-CLEAR	When Auto-CLEAR has been enabled in the PROFIBUS Master Unit, a failure of the GRT1-PRT will not cause an Auto-CLEAR event. The Master will however service the GRT1-PRT Unit (e.g. send new parameters).

**Configuration Data Convention**

The Configuration Data Convention setting defines how the GRT1-PRT will handle the special identifier format data parts of the Check I/O configuration message. The GRT1-PRT can perform the check either according to the original PROFIBUS DP standard, or according to the PROFIBUS DP-V1 standard. This allows the GRT1-PRT to use either standard PROFIBUS DP data types or extended PROFIBUS DP-V1 data types.

Control	Description
DPV1 Compliant	The Check I/O configuration message will contain PROFIBUS DP-V1 Data type definitions in the special identifier format data parts and the GRT1-PRT will perform the check on this assumption.
EN50170 Compliant	The Check I/O configuration message will contain standard PROFIBUS DP Data type definitions as well as vendor specific data types and the GRT1-PRT will perform the check on this assumption.

**Error on Cyclic Data Exchange**

The Error on Cyclic Data Exchange settings box, defines the behaviour of the PROFIBUS Master Units on the PROFIBUS network with respect to the GRT1-PRT, in case it fails to respond during I/O data exchange. Depending on the setting, the Master Unit will either continue sending I/O data exchange messages to the slave device, or abort I/O data exchange, and continue with requesting the GRT1-PRT Unit's diagnostics data. When continuing sending I/O data exchange data, the Unit's diagnostics data will not be updated.

Control	Description
Continue if slave not responding	The PROFIBUS Master Unit will continue to send I/O data exchange messages, when the GRT1-PRT device fails to respond. The diagnostics data of the GRT1-PRT will not be updated.
Abort if slave not responding	The PROFIBUS Master Unit will abort the data exchange with the GRT1-PRT Unit, and continue to send diagnostics request messages to the GRT1-PRT, until it responds. The diagnostics data of the GRT1-PRT will be updated accordingly.

**Note** A failure of the GRT1-PRT during I/O data exchange will always be reported to the CS1/CJ1 PLC CPU. If Auto-CLEAR has been enabled, the failure to respond will result in the PROFIBUS Master Unit switching to CLEAR mode.

### Diagnostics Update Delay

The Diagnostics Update Delay defines the number of PROFIBUS DP cycles during which the PROFIBUS Master Unit will ignore diagnostics message returned from the GRT1-PRT containing the Prm\_Req flag. During the Diagnostics Update Delay period the PROFIBUS Master Unit will continue requesting its diagnostics data.

### I/O Module Tab

The I/O Module Tab, shown below, defines the I/O Configuration for the GRT1-PRT. This I/O Configuration is downloaded to the PROFIBUS Master Unit and sent to the physical device by the Master Unit for verification at the start of communication.

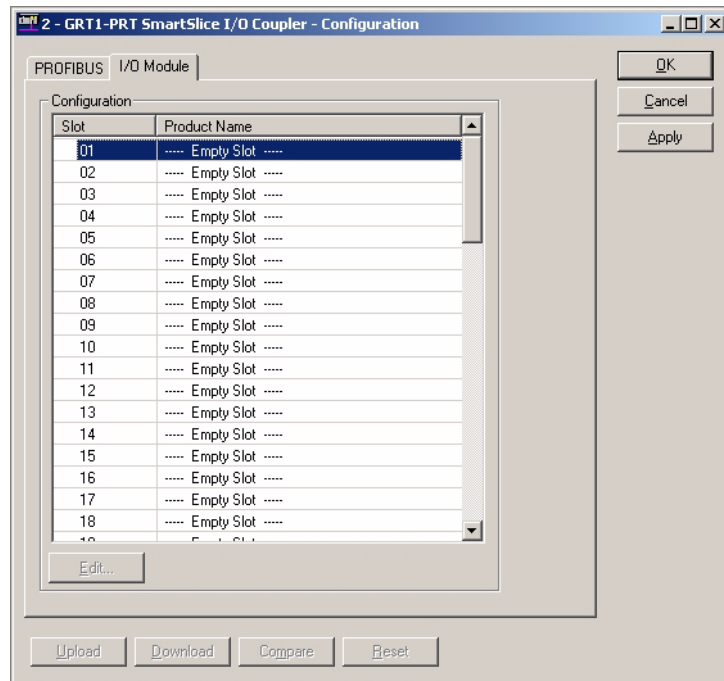

### Selecting the I/O Configuration

The I/O Configuration can be selected using the following procedure.

- 1,2,3... 1. Select the first row and double-click it using the left mouse button. A drop-down list will appear (see figure below).
2. From the drop-down list select the type of slice which is in this first slot, right next to the GRT1-PRT.
3. Select the next slot and repeat steps 1 and 2.



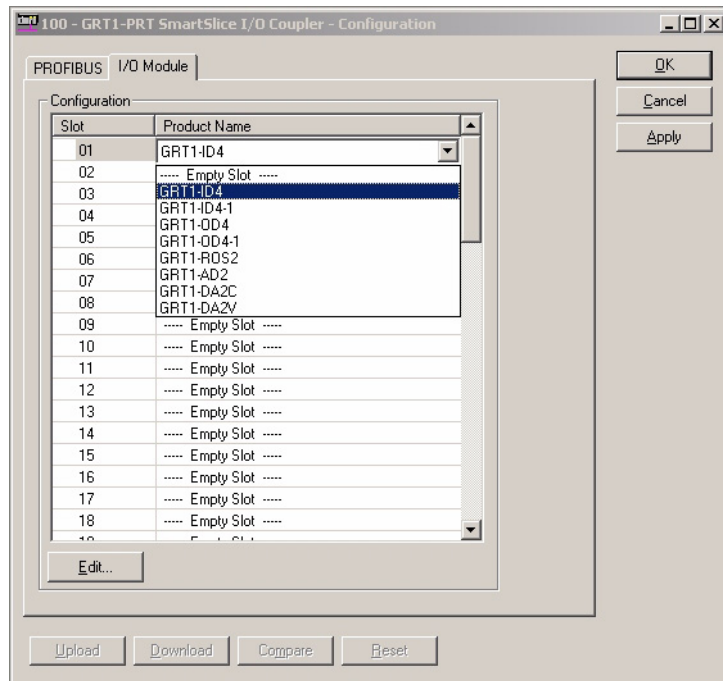

- Note**
1. Not shown in the list is the first input word, containing the GRT1-PRT Unit status word (refer to section 3-1-3 *SmartSlice I/O Allocation to the GRT1-PRT Unit* for an explanation on this word). The GRT1-PRT DTM automatically adds the status word to the I/O Configuration.
  2. The sequence of I/O devices selected in the I/O Module Tab must match the sequence of physical devices attached to the GRT1-PRT. Otherwise I/O Communication will not be achieved.
  3. The I/O Mapping of bit-sized SmartSlice I/O data in to distinct words is performed automatically by the GRT1-PRT.

As an alternative to selecting the I/O Configuration manually, the complete I/O Configuration can be downloaded from the GRT1-PRT Unit. To accomplish this, perform the following steps.

- 1,2,3...**
1. In the Network view, select the GRT1-PRT and right-click the mouse.
  2. From the context menu, which pops up, select the option **Go Online**.
  3. Press the **Upload** button. This will initiate an upload of all SmartSlice I/O Information, i.e. I/O Configuration, Unit types and Unit parameters. From this upload, the I/O Configuration in the Configuration list will be assembled automatically.

**Note** Uploading may take some time, due to the amount of parameters.

**Editing SmartSlice I/O Unit Settings**

After making the I/O configuration selection, the settings of individual SmartSlice I/O Units can be set or changed. To do this, perform the following steps.

- 1,2,3...**
1. Select the SmartSlice I/O Unit in the I/O Configuration.
  2. Press the **Edit** button below the I/O Configuration list. The appropriate setting window will pop up (see for example below).

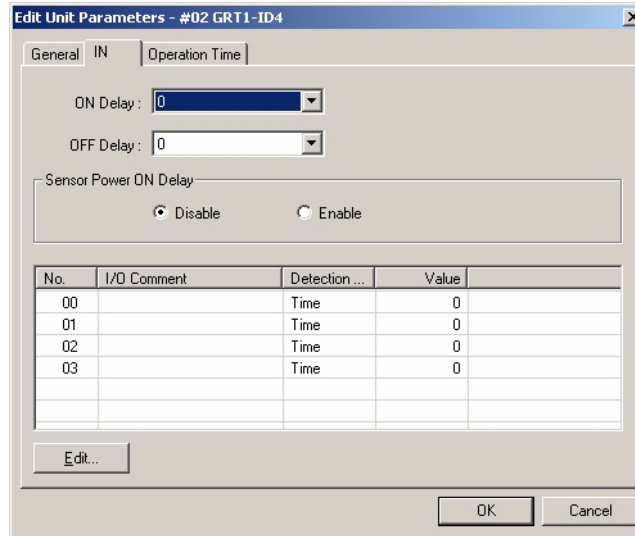

- Note**
1. In order to download/upload settings for individual SmartSlice I/O Units, the DTM has to be on-line with the Physical GRT1-PRT Unit, i.e. it has to be able to establish a connection with the device.
  2. In the case of the GRT1-AD2 some parameter settings will affect the I/O Configuration, i.e. it will change the I/O size for that particular SmartSlice I/O Unit. In that case, the I/O Configuration for the PROFIBUS Master Units needs to be (re-)downloaded. If this is required, an appropriate warning window will pop up.
  3. The configuration options and windows for individual SmartSlice I/O Units are described in detail in *GRT1 Series SmartSlice I/O Units Operation Manual (W455)*

**Using the On-Line Functions**

At the bottom of the GRT1-PRT DTM are four buttons which will be Enabled after the DTM has established communication with the physical device (via the PROFIBUS Master Unit). Switching to on-line must be done via the FDT Container. To switch to on-line, perform the following steps in Cx-Profibus.

- 1,2,3...**
1. In the Network view, select the GRT1-PRT and right-click the mouse.
  2. From the context menu, which pops up, select the option **Go Online**.
- The buttons functions are discussed below.

**Upload Button**

Pressing the **Upload** button will initiate an upload of all SmartSlice I/O Information, i.e. I/O Configuration, Unit types and Unit parameters. From this upload, the I/O Configuration in the Configuration list will be assembled.

**Note** Uploading may take some time, due to the amount of parameters.

**Download Button**

Pressing the **Download** button will initiate a download of all SmartSlice I/O Information, i.e. I/O Configuration, Unit types and Unit parameters.

**Compare Button**

Pressing the **Compare** button will initiate a comparison between the I/O Configuration and parameters of all SmartSlice I/O Units and the data stored

within the DTM. In case a mismatch is found, a warning screen will pop up to notify the user.

### Reset Button

Pressing the **Reset** button will initiate a system reset, i.e. the GRT1-PRT as well as the attached SmartSlice I/O Units will be reset. A Reset will also force the connected SmartSlice I/O Units to restore their settings from their non-volatile storage. In some cases a reset is a necessity to force the SmartSlice I/O Units to use newly written parameters.

**Note** If changes have been made via the SmartSlice I/O Unit's parameter windows, which require a system reset, the user is notified of this through a pop notification window.

## 3-3-3 Setup Using the GSD File

In case third-party Master Units are used, of which the Configuration software does not support FDT/DTM technology, the GRT1-PRT GSD File can be used to configure that master.

- Note**
1. Using the GSD File allows for I/O Configuration and I/O data exchange with the Master unit. It does not provide easy access to other Unit parameters.
  2. CS1/CJ1W-PRM21 PROFIBUS Master units can also be configured using the GSD File, although the DTM is available and has many more features.

The figure below shows the Generic Slave DTM, used in Cx-Profibus to handle GSD Files.

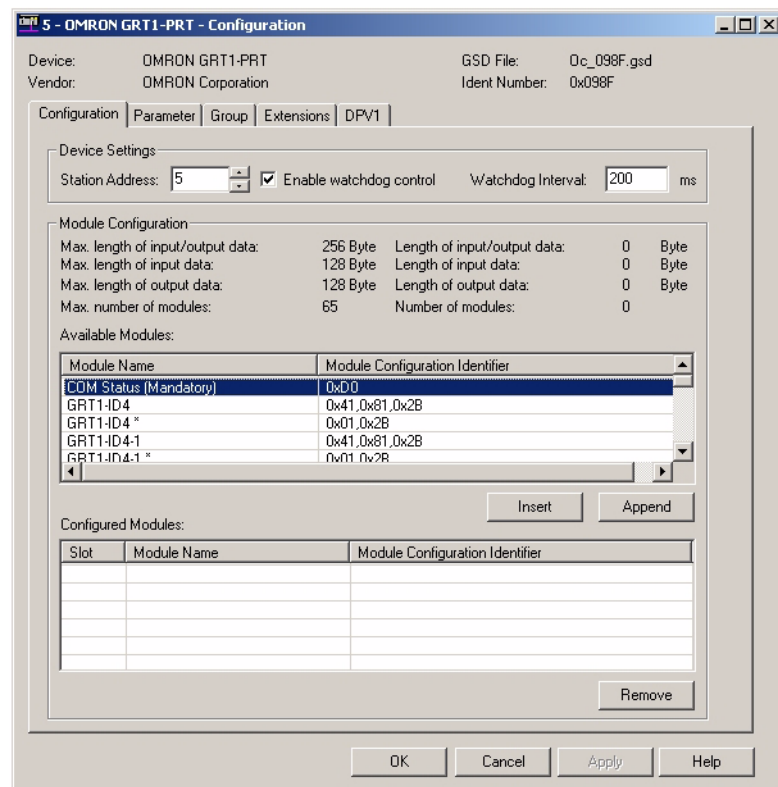

**Defining the I/O Configuration**

To define the I/O configuration, perform the following steps.

- 1,2,3...**
1. First select the COM status module (top of the list of available modules) by selecting and double-clicking the mouse using the left button. This module must always be selected first.
  2. Next select the individual I/O modules in the same sequence as they are physically connected to the GRT1-PRT. Observe the following.
    - Digital Units occupy 2 or 4 bits of I/O data. Adjacent digital Input Units or Output Units must be assembled in to 1 word.
    - To assemble multiple Digital Units, first select the appropriate Unit listed in the available Modules list, which is not marked with an asterisk. This will indicate the start of a new word. For the subsequent units the I/O modules marked with an asterisk must be selected until a word has been filled up.
    - When using digital input (or output) units after an analog input (or output unit), a new word has to be allocated. Select a module which is not marked with an asterisk
    - After a word has been filled up, a new word must be started by selecting again the next I/O module not marked with an asterisk.
    - Do not attempt to put Input Units and Output Units in one and the same word. This will result in a parameterization error, after downloading the configuration to the Master Unit.
    - Analog Units (e.g. GRT1-AD2 or GRT1-DA2V) occupy 1, 2 or 3 words.

To further explain the mapping sequence, an example is given below.

**Example**

To illustrate how the Digital and Analog SmartSlice I/O Units are mapped on to I/O words, and how to implement this using the GSD File, consider the table below:

SmartSlice Unit	Selected I/O Module	I/O Word/Bit
GRT1-PRT	COM Status	Input Word #1
GRT1-ID4	GRT1-ID4	Input Word #2 / Bit 0 ~ 3
GRT1-ID4	GRT1-ID4 *	Input Word #2 / Bit 4 ~ 7
GRT1-OD4	GRT1-OD4	Output Word #1, Bit 0 ~ 3
GRT1-ROS2	GRT1-ROS2 *	Output Word #1, Bit 4~ 5
GRT1-ID4	GRT1-ID4 *	Input Word #2 / Bit 8~ 11
GRT1-AD2	GRT1-AD2 (I: Analog Data) Default	Input Word #3 and #4

The table above lists the physical configuration in the left most column, the I/O Module selected for from the list of available I/O modules in the middle and the I/O words on to which the modules are mapped in the right-most column.

The figure below further illustrates the I/O Configuration selection.

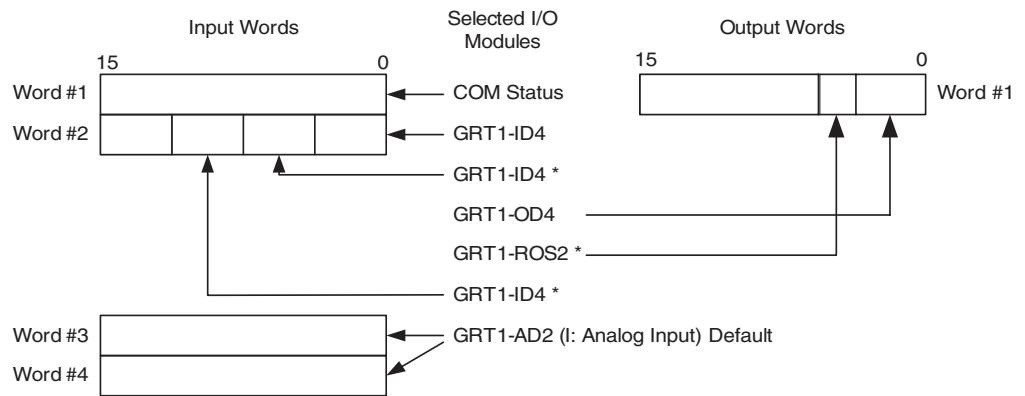

**Setting Parameters**

After selecting the I/O Configuration additional parameter settings can be made in the other tabs. These tabs will not be shown here, as they are similar to the settings explained in the previous section.

**Parameter Tab**

The Parameter Tab contains the setting for the FINS Fragment Length (See *FINS Fragment Length Setting* on page 44).

**Group Tab**

The Group Tab allows setting of the Group selections (See *Group Setting* on page 44).

**Extension Tab**

The Extension Tab contains the Auto-CLEAR, Configuration Data Convention, and the Error on Cyclic Data Exchange settings (See *Auto-Clear Processing* on page 44, and further).

**DPV1 Tab**

The DPV1 Tab contains settings related to DPV1.

**Caution** In the Generic Slave DTM, DPV1 Tab, the DPV1 Enable check box is enabled by default. For the GRT1-PRT this must be disabled. The GRT1-PRT only supports PROFIBUS DP-V1 Class 2 messages. If the flag has not been disabled, I/O data exchange will not be achieved.

For more information on using the Generic Slave DTM, refer to the *CS1/CJ1 PROFIBUS Master unit Operation Manual (W409)*.

### 3-3-4 Mapping I/O Data

The I/O Configuration can now be mapped on to the PROFIBUS Master Unit. The CS1/CJ1W-PRM21 PROFIBUS Master Unit provides a means to map individual I/O Configuration modules to specific memory areas.

For information on how to map the I/O data on to the PLC memory, refer to the *CS1/CJ1 PROFIBUS Master unit Operation Manual (W409)*.

#### Example

As an example, the I/O mapping of the I/O Configuration made using the Generic Slave DTM is shown in the window below.

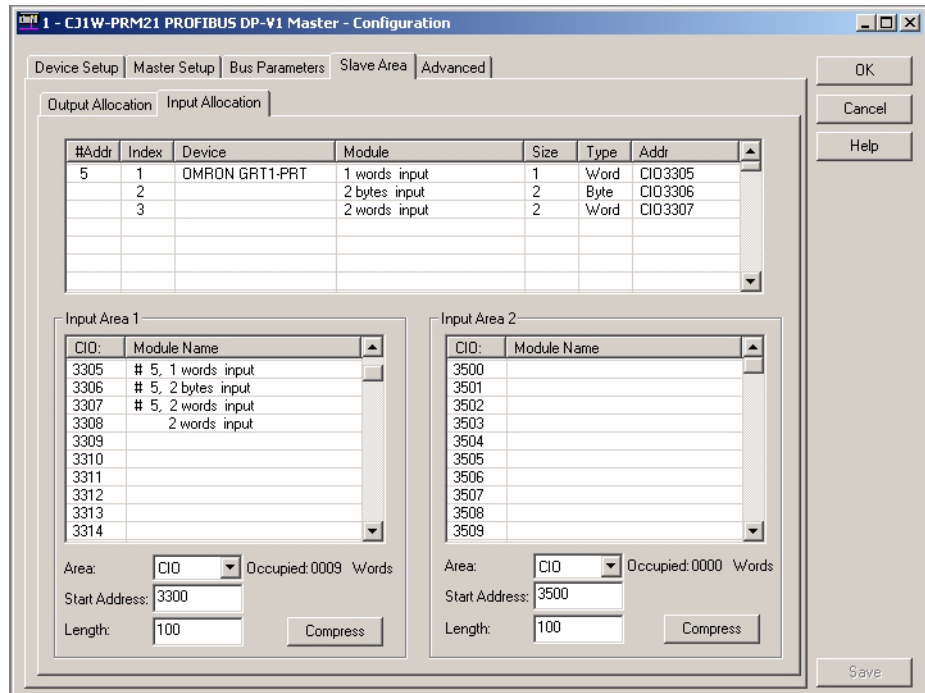

The window above shows the SmartSlice I/O Input data, mapped on to CIO 3305 to 3308. The first row indicates the COM Status word, the second row indicates the GRT1-ID Units, the third and fourth rows indicate the GRT1-AD2 Input data.

After setting up the I/O Configuration, it needs to be downloaded to the Master Unit, which is described in the *CS1/CJ1 PROFIBUS Master unit Operation Manual (W409)*. After download, the Master Unit needs to be switched to OPERATE mode, in order for it to start establishing communication.

### 3-4 Operating the Network

After network commissioning has been finished and there is communication between the PROFIBUS Master Unit and the GRT1-PRT, the GRT1-PRT DTM's additional features to monitor status can be used.

#### Switching the DTM to On-Line

To use these features, the GRT1-PRT must be on-line, i.e. the DTM must establish communication with the physical device (via the PROFIBUS Master Unit). Switching to on-line must be done via the FDT Container. To switch to on-line, perform the following steps in Cx-Profibus.

- 1,2,3...
1. In the Network view, select the GRT1-PRT and right-click the mouse.
  2. From the context menu, which pops up, select the option **Go Online**.

#### Monitoring Features

There are two types of Monitoring information

- PROFIBUS and SmartSlice I/O communication status
- SmartSlice I/O Unit status

#### 3-4-1 Monitoring the GRT1-PRT

To access status information on the PROFIBUS and SmartSlice I/O communication, perform the following steps.

- 1,2,3...
1. Select the GRT1-PRT in the Network View and right click the mouse.
  2. From the context menu, which pops up, select the Diagnosis option.

**Note** Only one GRT1-PRT can be monitored at a time. Opening two or more DTMs in monitoring mode may not function properly.

#### Example

A window will pop up showing PROFIBUS diagnostics information in the upper half of the window and SmartSlice I/O Communication in the lower half of the window. An example is shown below.

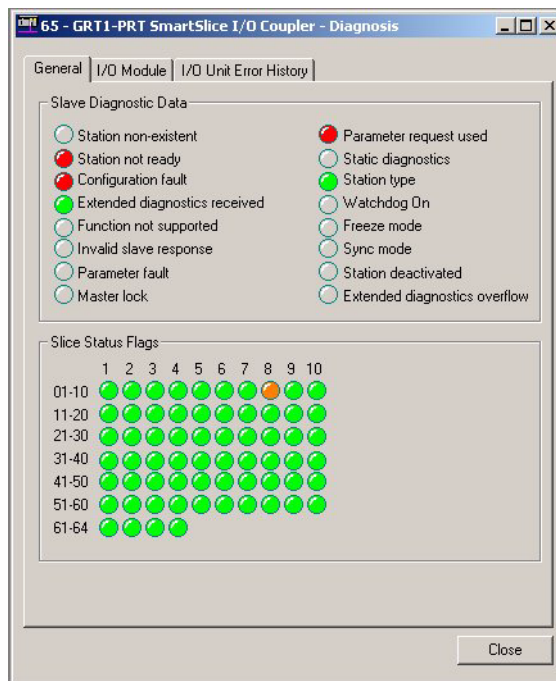

**PROFIBUS  
Communication Status**

The colour of the LED indicators in the window indicate either error (Red) or a status (Green). The PROFIBUS Communication status LED indicators represent the status bits in the GRT1-PRT Diagnostics message sent to the PROFIBUS Master Unit. Refer to *Appendix B Slave Diagnostics Message* for information on individual bit flags. In the example above, the GRT1-PRT has rejected the I/O Configuration because of a mismatch between the configuration provided by the PROFIBUS Master Unit and the physical SmartSlice I/O Unit configuration.

The GRT1-PRT is also requesting new parameter data from the Master Unit.

**SmartSlice I/O  
Communication status**

The lower half of the window shown above contains status LED indicators, which indicate the communication status of individual SmartSlice I/O Units. The LED indicators can have four colours.

Colour	Description
Grey	Grey LED indicators do not take part in communication and have also not been configured.
Green	Green LED indicators indicate correct I/O communication. There are no problems with the associated SmartSlice I/O Unit.
Orange	Orange LED indicators indicate that there is a SmartSlice I/O Unit present, but it is not the type, which was configured through the PROFIBUS DTM.
Red	Red LED indicators indicate a configured slot in which however no SmartSlice Unit is present.

The example above shows that the SmartSlice I/O Unit in slot 9 is different from the one that was configured. Consequently, the GRT1-PRT rejects the I/O Configuration, since it does not match the physical configuration.

**Example**

The window below shows another example, in which two slices which were configured are not present. The GRT1-PRT still accepts the I/O Configuration and performs data exchange over PROFIBUS.

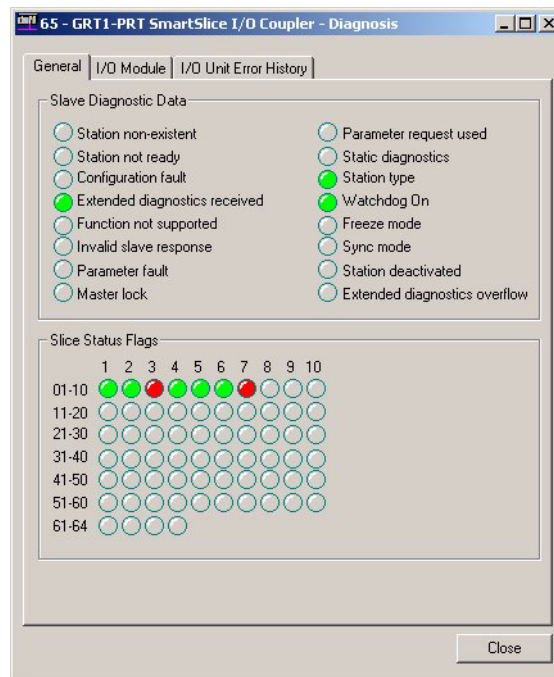



### 3-4-2 Monitoring the SmartSlice I/O System

Individual SmartSlice I/O Units can also be monitored through the PROFIBUS connection. This data can be retrieved through the I/O Module Tab and the I/O Error History Tab of the Diagnosis window.

**SmartSlice I/O Status**

When selecting the I/O Module Tab, the window as shown below will show up.

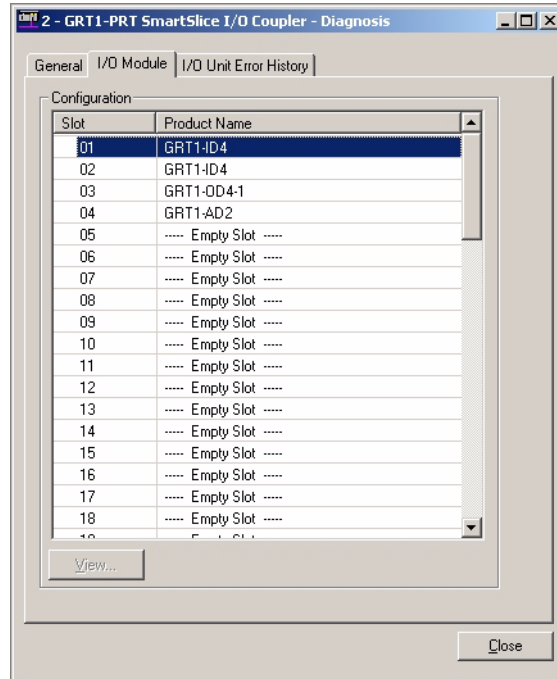

In case an on-line connection to the GRT1-PRT is open, the **View** button will be enabled. Selecting a SmartSlice I/O Unit and pressing the View button will open a status window for the selected SmartSlice I/O Unit. This information is described in detail in the *SmartSlice GRT1 Series Slice I/O Units Operation Manual (W455)*.

**I/O Unit Error History**

The I/O Unit Error History can be monitored, when selecting the I/O Unit Error History Tab. This window has also been described in section 3-2-5 *I/O Communication Error History Monitor*.

## 3-5 Remote Communication Characteristics

### 3-5-1 I/O Communication Characteristics

This section describes the characteristics of PROFIBUS I/O communication between a GRT1-PRT and an OMRON Master. Use this section for reference when planning operations that require precise I/O timing.

The equations provided here are valid under the following conditions:

- All of the required Slaves are participating in communication.
- No errors are being indicated at the Master Unit.
- No third-party Master or Configurator is being used in the network.

**Note** This manual describes the communication with the SmartSlice I/O System only. For details on the Master Unit or overall PROFIBUS network, refer to the *CS/CJ-series PROFIBUS DP Master Units Operation Manual (W409)*.

#### I/O Response Time

The I/O response time is the time it takes from the reception of an input signal at an Input Unit in the SmartSlice I/O System to the output on an Output Unit in the SmartSlice I/O System after being processed by the PLC program.

#### Minimum I/O Response Time

The minimum I/O response time ( $T_{MIN}$ ) is the total of the following terms:

$$T_{MIN} = T_{IN} + T_{SL-IN} + T_{SL-CI} + T_{RT-IN} + (T_{PLC} - T_{RF}) + T_{RT-OUT} + T_{SL-CO} + T_{SL-OUT} + T_{OUT}$$

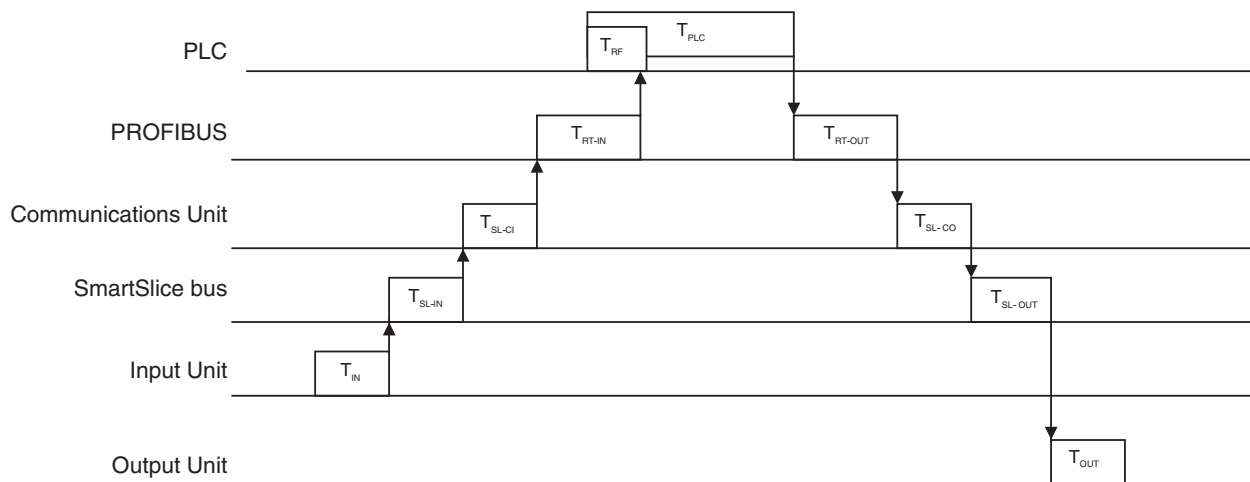

$T_{IN}$ : The Input Unit's ON (OFF) delay

$T_{OUT}$ : The Output Unit's ON (OFF) delay

$T_{SL-IN}$ : The SmartSlice bus' communication time (input data)

$T_{SL-OUT}$ : The SmartSlice bus' communication time (output data)

$T_{SL-CI}$ : The SmartSlice Communication Unit's input data processing time

$T_{SL-CO}$ : The SmartSlice Communication Unit's output data processing time

$T_{RT-IN}$ : The Input Slave's communication time/Slave

$T_{RT-OUT}$ : The Output Slave's communication time/Slave

$T_{RT}$ : The PROFIBUS communication time/Slave

$T_{PLC}$ : The PLC's cycle time

$T_{RF}$ : The PLC's PROFIBUS Unit refresh time

**Note** Refer to the *GRT1 Series SmartSlice I/O Units Operation Manual* for details on Input Unit's input delay times and Output Unit's output delay times.

**Maximum I/O Response Time**

The maximum I/O response time ( $T_{MAX}$ ) is the total of the following terms:

$$T_{MAX} = T_{IN} + 2 \times T_{SL} + T_{SL-CI} + T_{SL-CO} + 2 \times T_{RM} + 2 \times T_{PLC} + T_{RF} + T_{OUT}$$

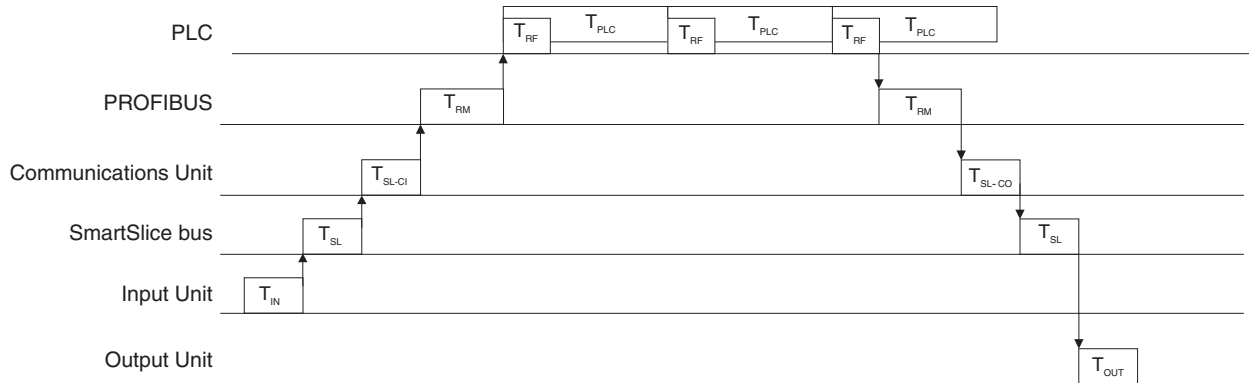

- $T_{IN}$ : The Input Unit's ON (OFF) delay
- $T_{OUT}$ : The Output Unit's ON (OFF) delay
- $T_{SL}$ : The SmartSlice bus communication cycle time
- $T_{SL-CI}$ : The SmartSlice Communication Unit's input data processing time
- $T_{SL-CO}$ : The SmartSlice Communication Unit's output data processing time
- $T_{RM}$ : The entire PROFIBUS communication cycle
- $T_{PLC}$ : The PLC's cycle time
- $T_{RF}$ : The PLC's PROFIBUS Unit refresh time

**Note** Refer to the *GRT1 Series SmartSlice I/O Units Operation Manual* for details on Input Unit's input delay times and Output Unit's output delay times.

**PROFIBUS Communication Cycle Time ( $T_{RM}$ )**

The PROFIBUS communication cycle time is the time from the completion of a Slave's remote I/O communication processing until remote I/O communication with the same Slave are processed again. The communication cycle time is used to calculate the maximum I/O response time.

The communication cycle time ( $T_{RM}$ ) is defined by the Bus parameter settings for the PROFIBUS Master Unit (Refer to the *CS/CJ-series PROFIBUS DP Master Units Operation Manual*).

**Refresh Time ( $T_{RF}$ )**

The refresh time is the time required to exchange I/O data between the PLC's CPU Unit and the PROFIBUS Master Unit. The PLC's cycle time is increased when a Master Unit is mounted, as shown below.

**Master Units for CS, CJ, C200HX/HG/HE (-Z), and C200HS PLCs**

When a Master Unit is mounted to the PLC, the PLC's cycle time (I/O refreshing) is increased by the amount shown in the following table.

PROFIBUS Master unit	I/O Refresh processing time
CS1/CJ1W-PRM21	$0.7 + 0.001 \times \text{number of words (ms)}$ (See note 1)
C200HW-PRM21	<ul style="list-style-type: none"> <li>• For C200HX/HG/HE (-Z) PLCs: <math>1.72 + 0.022 \times \text{number of words (ms)}</math> (See note 1)</li> <li>• For C200HS PLCs: <math>2.27 + 0.077 \times \text{number of words (ms)}</math> (See note 1)</li> </ul>

**Note** 1. The number of words refreshed is the total number of words in the I/O Area allocated to the Slaves, including any unused words between the allocated words. For example, if there are only two Input Slaves with station addresses 1 and 5, the 5 input words for stations 1 through 5 would be refreshed even though the input words for stations 2, 3, and 4 are unused.

2. If message communication is being performed, add the number of words used in message communication to the above number of words for whenever messages are being processed.
3. Refer to the PLC's operation manual for more details on the refresh time and the PLC's cycle time.

**Slice Bus Communication Cycle Time ( $T_{SL}$ )**

The SmartSlice bus communication cycle time is the delay in the SmartSlice I/O System from the end of communication with one I/O Unit until the start of communication with the next Unit.

**Communication Unit Processing Time ( $T_{SL-CI}$  and  $T_{SL-CO}$ )**

The PROFIBUS Communication Unit processing time is the time required for software processing in the Communication Unit.

**Slice Bus Communication Time ( $T_{SL-IN}$  and  $T_{SL-OUT}$ )**

The Slice bus communication time is the time required to communicate with an Input Unit ( $T_{SL-IN}$ ) or Output Unit ( $T_{SL-OUT}$ ) in the SmartSlice I/O System.

$T_{SL}$ ,  $T_{SL-CI}$ ,  $T_{SL-CO}$ ,  $T_{SL-IN}$  and  $T_{SL-OUT}$  strongly depend on the number of SmartSlice I/O Units as well as on the amount of I/O data per SmartSlice I/O Unit. The examples below present an indicative measure for the time required to process PROFIBUS output data.

**Example**

The image below shows the GRT1-PRT DTM with a typical SmartSlice I/O Unit configuration.

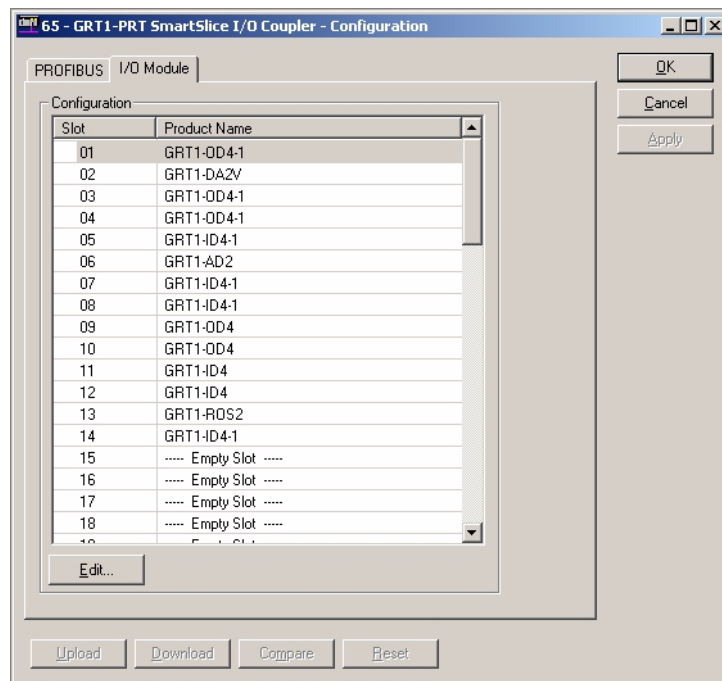

All Unit functions set by DIP switches (see section 3-2 *Unit Functions*) on the GRT1-PRT PROFIBUS Communication Unit are enabled (recommended setting) and the PROFIBUS communication is being operated at 1500 kbit/s. The approximate minimum and maximum time intervals from PROFIBUS output data to be received by the GRT1-PRT and the intended output signal to be present on the output terminal is shown below for various configurations.

SmartSlice Configuration	min [ms]	max [ms]
Minimum (one GRT1-OD4-1 and one GRT1-ID4-1)	0.6	2.2
Typical (See image above)	1.4	4.4
Maximum (64 digital SmartSlice I/O Units)	3.4	11

- Note**
1. The processing time required for an input signal on an input terminal to be transferred to a PROFIBUS input data message is of the same order of magnitude as the numbers presented above.
  2. Setting the DIP switches to OFF, will extend the processing time with an approximate 2 ms.

### 3-5-2 Message Communication Characteristics

The message communication time is the time required for a message sent to the SmartSlice I/O System to travel over the Network and arrive at the SmartSlice I/O Unit. (The message may be data from a SEND(090)/RECV(098) instruction or a FINS command from a CMND(490)/IOWR(223) instruction.)

#### Communication Time to the PROFIBUS Communication Unit

The time required for a message to be sent is the same as the PROFIBUS cycle time, since the acyclic message are sent at the end of a cycle, prior to the next one.

#### Communication Time to the SmartSlice I/O Unit

If a SmartSlice I/O Unit is the final message destination, the message communication time over the SmartSlice bus must be added to calculate the total message communication time. Use the following equation to calculate the message communication time over the Slice bus.

$$\text{Message communication time} = T_{SL} \times \text{Number of frames}$$

$$\text{Number of frames} = \text{Number of message bytes} \div 30 \text{ (round up fractions)}$$

- Note**
1. If the CPU Unit attempts to send another message or receives a message from another station before the message communication time has finished, the response message being sent or the message being received from another station may be destroyed. Always perform message communication at intervals longer than the message communication time and use message instructions (SEND(090), RECV(098), CMND(490), and IOWR(223)). Never send messages to any one station at intervals less than the message communication time.  
If send or receive messages are destroyed, the error record will be placed in the error history of the Master Unit. If an error occurs, read the error history using the FINS command or monitor the error history from the Configurator.
  2. The above equations provide find the approximate message communication time, but not the maximum time. The message communication time will depend on the frequency of the message communication, the load on the remote station, the communication cycle time, and other factors. For any one Master Unit, the message communication time may be greatly increased due to heavy loads.

# SECTION 4

## Troubleshooting and Maintenance

This section describes the troubleshooting procedures and maintenance operations for the PROFIBUS Communication Unit, needed to keep the PROFIBUS network optimally working.

4-1	Overview . . . . .	60
4-2	Troubleshooting using the LED Indicators . . . . .	60
4-2-1	Power Supply Errors . . . . .	61
4-2-2	Unit System Errors . . . . .	62
4-2-3	SmartSlice I/O System Errors . . . . .	62
4-2-4	PROFIBUS Errors . . . . .	63
4-3	Other Errors . . . . .	64
4-3-1	Troubleshooting SmartSlice I/O Communication . . . . .	64
4-3-2	Troubleshooting Profibus Communication . . . . .	65
4-3-3	SmartSlice I/O Unit Error History . . . . .	67
4-4	Maintenance . . . . .	69
4-4-1	Cleaning . . . . .	69
4-4-2	Inspection . . . . .	69
4-5	Replacing the Unit . . . . .	70
4-5-1	Replacement Precautions . . . . .	70
4-5-2	Setting the Unit after Replacement . . . . .	70

## 4-1 Overview

The PROFIBUS Communication Unit and the Configuration DTM provide extensive means for troubleshooting, which can be used to quickly determine errors in the Unit, in the SmartSlice I/O configuration, and/or in the network.

### Troubleshooting on the GRT1-PRT Unit

For troubleshooting purposes, the following error indicators can be used:

- LED indicators on the front of the Unit  
Three red error LED indicators and four status LED indicators show Unit and SmartSlice I/O system status and errors.
- The Error Log collects error codes for various error events. The Error Log can be retrieved using the GRT1-PRT DTM.
- PROFIBUS errors  
DP-V1 commands provide defined response codes, which can indicate specific errors.

This section provides a number of procedures for troubleshooting, based on the error indicators listed above.

## 4-2 Troubleshooting using the LED Indicators

The figure below shows the available LED indicators on the PROFIBUS Communication Unit and on the SmartSlice I/O system attached to it. The GRT1-PRT and the SmartSlice I/O Units are operating normally when all of the LED indicators are lit green.

- RUN LED: Indicates the status of the PROFIBUS Communication Unit.
- ERR LED: Indicates the status of PROFIBUS Communication Unit.
- BF LED: Indicates the status of the PROFIBUS Communication Unit.
- TS LED: Indicates the status of the SmartSlice I/O System.
- UNIT PWR: Indicates the status of the Unit power supply.
- I/O PWR: Indicates the status of the I/O power supply.

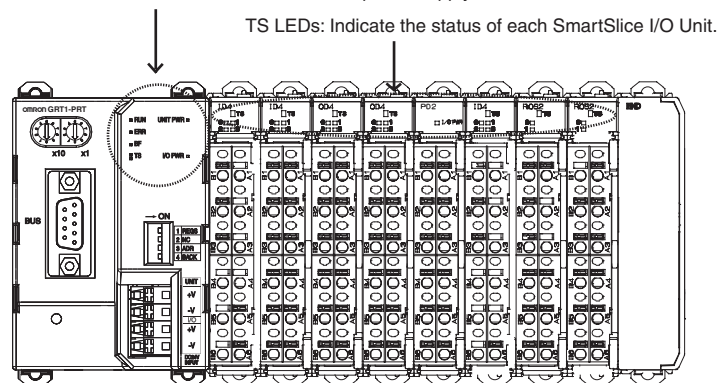

**Note** Not shown in the figure above is a Turnback Unit. The Turnback Unit also provides I/O PWR, UNIT PWR and TS LED Indicators.

The LED indicators can be used to determine the following categories of errors

- Power errors
- Startup errors
- SmartSlice I/O Unit errors
- PROFIBUS errors

### 4-2-1 Power Supply Errors

Errors in the Power supply of the Unit or the external I/O are indicated by the UNIT PWR and I/O PWR LED Indicators.

#### Troubleshooting UNIT Power

The UNIT PWR LED Indicator shows whether or not sufficient power is supplied to the PROFIBUS Communication Unit and the SmartSlice I/O Units in order for them to startup and operate properly. A UNIT PWR LED Indicator is provided on the following Units:

- GRT1-PRT PROFIBUS Communication Unit
- GRT1-TBL Left Turnback Unit

The table below shows the LED Indicator options.

#### Unit Power Error

UNIT PWR	Probable cause	Correction
Not lit	No Power or not enough power is being supplied to the Units (See note)	<ul style="list-style-type: none"> <li>• Check whether power is supplied to the Unit Power Connector.</li> <li>• Check that the supplied power is with in the required range, i.e. 24 Vdc +10% -15% (20.4 to 26.4 Vdc).</li> </ul>
Flashing	The Unit power supply capacity is insufficient.	<ul style="list-style-type: none"> <li>• Check the entire SmartSlice I/O System's power supply requirement and replace the power supply with one that has sufficient capacity.</li> </ul>
Lit	No Unit power error. The correct power is supplied to the System.	

**Note** The PROFIBUS Communication Unit can startup on less power than specified. If this happens, the UNIT PWR LED Indicator may be OFF, whereas other LED Indicators may indicate correct operation. In this situation however, correct operation of the whole SmartSlice I/O System is not guaranteed.

#### Troubleshooting I/O Power

The I/O PWR LED Indicator shows whether or not sufficient power is supplied to the External I/O Power lines to the SmartSlice I/O Units in order for them to drive the external Outputs on the individual Units.I/O slices. A I/O PWR LED Indicator is provided on the following Units:

- GRT1-PRT PROFIBUS Communication Unit
- GRT1-TBL Left Turnback Unit
- GRT1-PD2 I/O Power Supply Unit

The table below shows the LED Indicator options.

#### I/O Power Error

I/O PWR	Probable cause	Correction
Not lit	No Power or not enough power is being supplied to the External I/O of the SmartSlice I/O Units	<ul style="list-style-type: none"> <li>• Check whether power is supplied to the I/O Power Connector on the GRT1-PRT, the GRT1-TBL or the GRT1-PD2 Unit.</li> <li>• Check that the supplied power is with in the required range, i.e. 24 Vdc +10% -15% (20.4 to 26.4 Vdc).</li> </ul>
Lit	No I/O power error. The correct power is supplied to the External I/O System.	



### 4-2-2 Unit System Errors

If power supply to the Unit and the SmartSlice I/O Units is correct, the Unit will start initialization at power up. During the Initialization process the RUN LED indicator will remain OFF. Once the initialization has been completed correctly, the RUN LED indicator will be ON.

The table below indicates the states which can occur during startup and operation of the Unit.

RUN	ERR	Probable cause	Correction
Not Lit	Not Lit	Unit is initializing	--
	Flashing	Unit has encountered a fatal system error during initialization and is unable to continue.	Replace the Unit.
	Lit	The Unit has been initialised, but encountered fatal error during Operation.	Restart the Unit. If the problem persists, replace the Unit.
Lit	Not Lit	The Unit is Operational. No errors encountered.	
	Lit	Not a valid combination.	

### 4-2-3 SmartSlice I/O System Errors

If power supply to the Unit is correct and the Unit has initialized correctly, problems in the SmartSlice I/O system can be determined using the TS LED indicators on the PROFIBUS Communication Unit as well on the individual SmartSlice I/O Units. When lit or flashing, the TS LED indicator can be either Green or Red.

The tables below lists the TS LED indicator options.

#### Communication Unit

TS	Colour	Probable cause	Correction
Not Lit	---	Power is not being supplied to the Unit.	Refer to section 4-2-1 <i>Power Supply Errors</i> .
Flashing (1 Hz)	Green	Joining SmartSlice I/O Units to network.	Wait until the SmartSlice I/O Units have been added to the network.
		There is a possible break in the connection between individual slices, or one of the SmartSlice sockets has not been connected properly to its left neighboring connector. The TS LED Indicator on all correctly connected slices are flashing, whereas the TS LED Indicators on the non-correct Units are Not Lit (OFF).	Check the connection between slices at the point where the first Unit is located with its TS LED Indicator OFF. Ensure that all slices are connected correctly to each other.
		The End Unit is not (properly) attached. SmartSlice Communication does not start up. The TS LED Indicator on all SmartSlice I/O Units slices are flashing.	Check the End Unit connection and ensure that it is correctly connected to the SmartSlice system.
	Red	SmartSlice bus communication error occurred.	Check whether the SmartSlice I/O System's base block is connected properly.
		When the registration table function is enabled, the actual configuration does not match the registered configuration.	Correct the configuration and turn the power ON again.
		The total number of I/O points in the SmartSlice I/O Systems exceeds the maximum.	Correct the Unit configuration and number of I/O points and turn the power ON again.
Flashing (2 Hz)	Green	Restore operation in progress	Wait until the restore operation is completed.
		Backup operation in progress	Wait until the backup operation is completed.

TS	Colour	Probable cause	Correction
Lit	Red	Backup operation failed (See Note).	Backup the data again.
		Restore operation failed (See Note).	Reinstall the Unit in which the data was being restored and turn the power ON again.
		SmartSlice I/O Unit configuration error occurred.	Check the following items. <ul style="list-style-type: none"> <li>• Are more than 64 I/O Units connected?</li> <li>• Are more than 128 bytes of I/O data being used?</li> <li>• Has the I/O configuration changed since the I/O configuration table was registered?</li> </ul>
	Green	The Slice bus is operating normally.	---

**Note** Backup/Restore Operation failed: TS LED Indicator will be Lit for 2 seconds.

**SmartSlice I/O Unit**

TS	Colour	Probable cause	Correction
Not Lit	--	Power is not being supplied to the Unit.	Refer to section 4-2-1 Power Supply Errors.
Flashing (1 Hz)	Red	Communication error occurred.	Check whether the connector is inserted properly.
Flashing (2 Hz)	Green	Restore operation in progress	Wait until the restore operation is completed.
		Backup operation in progress	Wait until the backup operation is completed.
Lit	Red	Unit hardware failure	Turn the power OFF and then ON again. Replace the Unit if the error recurs.
	Green	SmartSlice I/O Unit operating normally.	---

**4-2-4 PROFIBUS Errors**

If power supply to the Unit is correct and the Communication Unit and the SmartSlice I/O Units are operating correctly, problems in the PROFIBUS Connection can be determined using the BF LED indicator (Bus Fail) on the PROFIBUS Communication Unit. The tables below lists the BF LED options.

BF	Probable cause	Correction
Not lit	No PROFIBUS Communication error encountered. The Unit is exchanging I/O data with the Master Unit.	
Flashing	The PROFIBUS configuration is not correct. There is however communication with Master Unit.	<ul style="list-style-type: none"> <li>• Check the configuration and the parameter data of the slave (See Note 1).</li> <li>• Verify that the first selected I/O module is the “COM status” Module (see Note 2).</li> <li>• Verify that the selected configuration matches the physical slice configuration attached to the PROFIBUS Communication Unit.</li> <li>• Verify the Profibus allocation of the SmartSlice I/O Unit is according the description. Check the Profibus Diagnostics. Please refer to <i>Appendix B Slave Diagnostics Message</i>.</li> </ul>
Lit	The PROFIBUS configuration is not correct. There is NO communication with master.	<ul style="list-style-type: none"> <li>• Verify that the Unit has the same station address as in the master's configuration.</li> <li>• Verify that no station address is used twice.</li> <li>• Verify that the Master Unit is ON-LINE.</li> </ul>

BF	Probable cause	Correction
Lit	The PROFIBUS wiring is not correct.	<ul style="list-style-type: none"> <li>Verify that the correct pins of the BUS connector are connected.</li> <li>Verify that there are no short circuits or line interruptions,</li> <li>Verify that the correct cable type is used,</li> <li>Verify that the stub lines are not too long. See 2-4-1 <i>Network Structure</i>).</li> </ul>
	The PROFIBUS network has not been terminated correctly.	Terminate the network at the appropriate places. See 2-4-2 <i>Bus Termination</i> ).

- Note**
- If two or more SmartSlice I/O Units do not match with the PROFIBUS I/O configuration, the diagnostics message will only contain the error flags of the first mismatching SmartSlice I/O Unit.
  - Selecting the COM Status module applies to the use of the GSD file in third-party Configuration software. When using the GRT1-PRT DTM within an FDT container, the COM Status module is selected automatically, and remains hidden to the user.

## 4-3 Other Errors

### 4-3-1 Troubleshooting SmartSlice I/O Communication

This section deals with troubleshooting the SmartSlice I/O communication on the network from a behaviour point of view. The column on the left describes the general perceived problem to the user. The columns on the right list the possible causes and their remedies.

Problem	Probable cause	Correction
<p>The Communication Unit's Unit Power LED is flashing.</p> <p>The I/O Unit repeatedly checks LEDs (TS LED flashing green and red).</p>	The Unit power supply capacity is insufficient.	Check the entire SmartSlice I/O System's power supply requirement and replace the power supply with one that has sufficient capacity.
The Communication Unit's TS LED intermittently flashes green. The TS LED of the I/O Units in front of the bad connection light green, while the TS LED of the I/O Units behind the bad connection are OFF.	<p>The slide connector on the left side of the affected Unit is not connected properly.</p>	Connect this slide connector properly and turn the power ON again.
The Communication Unit's TS LED flashes green and the I/O Unit's TS LED is ON.	<p>The End Unit is not connected properly.</p>	Connect the End Unit properly and turn the power ON again.

### 4-3-2 Troubleshooting Profibus Communication

Problem	Probable cause	Correction
PROFIBUS DP Master Unit is configured, but only the SmartSlice I/O Unit is not exchanging data.	The PROFIBUS configuration of the master for the Unit is not correct.	<ul style="list-style-type: none"> <li>• Verify that the first selected I/O module is the "COM status" Module (see Note).</li> <li>• The SmartSlice I/O Unit supports Profibus DPV1 Class 2, not DPV1 Class 1. The slave configuration must not have the DPV1 class 1 option enabled (hence the DPV1 tab of the Generic Slave DTM). Always disable the DPV1 class 1 setting for the Unit.</li> <li>• Check the configuration and the parameter data of the slave.</li> <li>• Verify that the selected configuration matches the physical slice configuration attached to the PROFIBUS Communication Unit.</li> <li>• Verify the Profibus allocation of the Smart-Slice I/O Unit is according the description. Check the Profibus Diagnostics. refer to <i>Appendix B Slave Diagnostics Message</i>.</li> </ul>
	The SmartSlice bus has one of the following problems at start-up: <ul style="list-style-type: none"> <li>• One or more SmartSlice Units are missing.</li> <li>• Disconnected turn-back cable.</li> </ul> The PROFIBUS configuration for the Unit can not be compared with the actual configuration. The SmartSlice I/O Units PROFIBUS Diagnostics indicates that the Unit is in state Not Ready.	Connect the Smart Slice Units and the cables properly and turn the power ON again.
PROFIBUS DP Master Unit is configured, but none of the slaves are exchanging data.	No power is supplied to the system. <ul style="list-style-type: none"> <li>• All LED indicators on the system are OFF.</li> </ul>	<ul style="list-style-type: none"> <li>• Verify that power is supplied to the system.</li> </ul>
	The PROFIBUS DP Master Unit is in either OFF-LINE or STOP mode. <ul style="list-style-type: none"> <li>• The Master's BST LED indicator is OFF The Master Unit may have been configured to maintain its current mode (last mode was OFF-LINE, during download).</li> <li>• The Master's and BF the Unit's LED indicator are ON: A PROFIBUS interface error has occurred: see Master Status 2 error flags (Master CIO Word n+6, bit 00 ~ 03, see Note) for details.</li> </ul>	Determine the mode of the Master Unit: Check the Master Status 1 Word (Master CIO Word n+5, bit 00 to bit 03, see Note). If Unit is in OFF-LINE or STOP mode: <ul style="list-style-type: none"> <li>• Verify that the master does not use the same address as another Master Unit on the network. Otherwise, correct the Master Unit's PROFIBUS address.</li> <li>• Set CLEAR or OPERATE switch in Master CIO Word n (see Note).</li> <li>• Change the configuration to set the Master Unit OPERATE mode when switching the PLC to RUN/MONITOR mode (see Master DTM, Master Setup Tab). Download the configuration, and switch the PLC to RUN/MONITOR mode.</li> </ul>
	Network cabling is not correct. <ul style="list-style-type: none"> <li>• Master BF LED and/or Unit BF LED indicator is ON.</li> <li>• Master Status 2 error flag may provide more information (Master CIO Word n+6, bit 00 ~ 03, see Note).</li> <li>• Master CIO Words n+9 to n+16 show which slaves have problems.</li> </ul>	Verify that the network installation is correct: <ul style="list-style-type: none"> <li>• Verify that all slaves are powered up and functioning correctly.</li> <li>• Verify that all slave devices are correctly connected to the network.</li> <li>• Verify that any repeaters used are functioning correctly.</li> <li>• Check the cable length versus the selected baud rate.</li> <li>• Verify that used stubs are not too long.</li> <li>• Verify that termination (resistors and inductors) are properly set and used.</li> </ul>

Problem	Probable cause	Correction
PROFIBUS DP Master Unit is configured. Some, but not all slaves exchange data.	Network cabling is not correct. <ul style="list-style-type: none"> <li>• Master's and/or Unit's BF LED indicator is ON or Flashing.</li> <li>• Master Status 2 error flag may provide more information (Master CIO Word n+6, bit 00 ~ 03, see Note).</li> <li>• Master CIO Words n+9 to n+16 show which slaves have problems.</li> </ul>	Verify that the network installation is correct: <ul style="list-style-type: none"> <li>• Verify that all slaves are powered up and functioning correctly.</li> <li>• Verify that all slave devices are correctly connected to the network.</li> <li>• Verify that any repeaters used are functioning correctly.</li> <li>• Check the cable length versus the selected baud rate.</li> <li>• Verify that any stubs used are not too long.</li> <li>• Verify that termination (resistors and inductors) are properly set and used.</li> </ul>
	Configuration is not correct. <ul style="list-style-type: none"> <li>• Master BF LED indicator is Flashing.</li> <li>• Master CIO Words n+9 to n+16 show which slaves have problems.</li> <li>• Use Cx-Profibus and DTMs to determine slave diagnostics.</li> </ul>	Verify that the configuration is correct: <ul style="list-style-type: none"> <li>• Verify that address of targeted slave device matches the configured address.</li> <li>• Verify that the slave parameter and configuration settings are correct.</li> <li>• Verify that the watchdog setting for the slave device is not too low.</li> </ul>
	The configuration contains timing errors. <ul style="list-style-type: none"> <li>• Master's BF LED indicator is Flashing.</li> <li>• Slaves are sometimes briefly in and out of data exchange.</li> </ul>	<ul style="list-style-type: none"> <li>• Verify that the Bus parameter sets are correct. If necessary, increase Target Rotation Time and/or Min. Slave Interval parameters.</li> <li>• Re-download the configuration.</li> <li>• If the problem persists, replace the Unit.</li> </ul>
	Specific slave devices are configured and allocated to the Master Unit, but the slave which is not exchanging data may have been disabled using the FINS STOP command.	Use the FINS RUN command to enable the slave devices.
PROFIBUS DP Master Unit is configured. All slaves were in data exchange, but it has now stopped.	No power is supplied to the system. All LED indicators on the system are OFF.	<ul style="list-style-type: none"> <li>• Verify that power is supplied to the system.</li> </ul>
	The PROFIBUS DP Master Unit is in either OFF-LINE or STOP mode. <ul style="list-style-type: none"> <li>• The Master BST LED indicator is OFF</li> <li>• The Master and/or Slaves' BF LED indicators are ON: A PROFIBUS interface error has occurred: see Master Status 2 error flags (Master CIO Word n+6, bit 00 ~ 03, see Note) for details.</li> </ul>	Determine the mode of the Master Unit: Check the Master Status 1 Word (Master CIO Word n+5, bit 00 to bit 03, see Note). If Master Unit is in OFF-LINE or STOP mode: <ul style="list-style-type: none"> <li>• Verify that the master does not use the same address as another Master Unit on the network. Otherwise, correct the Master Unit's PROFIBUS address.</li> <li>• Set CLEAR or OPERATE switch in CIO Word n (see Note).</li> </ul>
	Network cabling is not correct. <ul style="list-style-type: none"> <li>• Master and/or Slaves' BF LED indicator are ON.</li> <li>• Master Status 2 error flag may provide more information (CIO Word n+6, bit 00 ~ 03, see Note).</li> </ul>	Verify that the network installation is correct: <ul style="list-style-type: none"> <li>• Verify that the network is still in tact, and connected to the Unit.</li> <li>• Verify that any repeaters used are functioning correctly.</li> </ul>
PROFIBUS DP Master Unit is configured. All slaves were in data exchange, but all outputs are now set to zeros. Inputs can still be read.	The Master Unit is in CLEAR mode. <ul style="list-style-type: none"> <li>• The BST LED indicator is Flashing.</li> <li>• The CLEAR switch has been set in the Switch word 1 (CIO Word n, bit 02, see Note)</li> <li>• The Unit has been configured for Auto-CLEAR and an error occurred on the Network with one or more slave devices.</li> </ul>	<ul style="list-style-type: none"> <li>• If Auto-CLEAR is enabled, correct the network problem first.</li> <li>• Set OPERATE switch in CIO Word n (see Note) to force the Unit to the OPERATE mode.</li> </ul>

Problem	Probable cause	Correction
PROFIBUS DP Master Unit is configured. All slaves are in data exchange, but the outputs of some slave devices are not updated.	The specified slave devices may be in Sync mode.	Send a Global-Control Unsync command to the targeted slave or group of slaves, using the Global-Control feature in CIO Words.
	The specified slave device may have its watchdog disabled and is disconnected from the network, due to a cabling problem. <ul style="list-style-type: none"> <li>• Master BF LED indicator is Flashing.</li> <li>• Master CIO Words n+9 to n+16 (see Note) show which slaves have problems.</li> <li>• Use Cx-Profibus and DTMs to determine slave diagnostics.</li> </ul>	Verify that the specified slave device is still connected to the network.
PROFIBUS DP Master Unit is configured. All slaves are in data exchange, but the inputs of some slave devices are not updated.	The specified slave devices may be in Freeze mode.	Send a Global-Control Unfreeze command to the slave or group of slaves. Use either the Global-Control feature in CIO Words.
	The specified slave device may have its watchdog disabled and is disconnected from the network, due to a cabling problem. <ul style="list-style-type: none"> <li>• Master BF LED indicator is Flashing.</li> <li>• Master CIO Words n+9 to n+16 (see Note) show which slaves have problems.</li> <li>• Use Cx-Profibus and DTMs to determine slave diagnostics.</li> </ul>	Verify that the specified slave device is still connected to the network.
PROFIBUS Master Unit is configured. All slaves are in data exchange, but the parameters and status information can not be accessed.	The station address of the GRT1-PRT has been set to 00. This address is reserved for Master Units in the messaging services protocol.	Set the station address to another value than 00, and restart the GRT1-PRT and the SmartSlice I/O System.

**Note** n = CIO 1500 + (25 x unit number).

### 4-3-3 SmartSlice I/O Unit Error History

The PROFIBUS Configurator can read the error history details of the most recent errors that occurred in the SmartSlice I/O Units.

#### Error History Tab Page

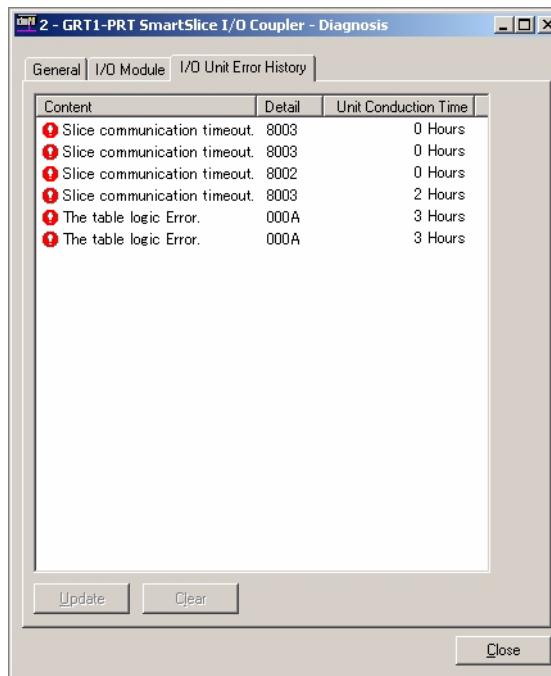

## Communication Unit Error History

Error code (Hex)	Meaning	Detailed Error Code		Corrective action	Non Volatile
		1st byte	2nd byte		
0002	WDT error	0x00	0x00	Replace the Unit if the error occurs frequently.	Yes
0370	Verification error (Slave missing)	00	00	Connect the missing Unit and restart.	No
0372	Verification error (unregistered Slave joined network)	0x80: Slice I/O	Node address (Hex)	Remove the unregistered Unit and restart.	No
021A	Setting table logic error Cause: There was a checksum error in one of the following tables or a set value was out-of-range. <ul style="list-style-type: none"> <li>• Network parameters</li> <li>• Registration table</li> <li>• Slave parameters</li> <li>• Backup restore data</li> </ul>	0x00	0x0A: Registration table 0x0B: Slave parameters 0x0C: Network parameters 0x0F: Backup restore data	Download the settings again.	Yes
0602	Memory access error Cause: <ul style="list-style-type: none"> <li>• A hardware error occurred in the Unit's internal non-volatile memory.</li> <li>• E2P hardware error</li> <li>• Backup communication failure</li> <li>• FROM save failure</li> <li>• EEPROM save failure</li> <li>• FROM hardware error</li> <li>• ADR failure (communication failure)</li> </ul>	0x01: Read error 0x02: Write error	0x07: Error history 0x09: Identity information 0x0A: Registration table 0x0C: Network parameters 0x0F: Backup restore data (E2P/FROM)	Replace the Unit if the error occurs frequently.	Yes (No for error history only)

## Slice Bus Error History

Error code (Hex)	Meaning	Detailed Error Code		Corrective action	Non Volatile
		1st byte	2nd byte		
0300	Backup data reception error	0x80: Slice I/O	Node address (Hex)	Verify that the Unit is connected properly. Check for excessive environmental noise	No
0374	Transmission error Cause: A transmission error occurred.	0x80: Slice I/O	Node address (Hex)	Verify that the Unit is connected properly. Check whether there is excessive noise in the surroundings.	No
0375	Communication stopped due to a transmission error. Cause: The Unit is set to stop communication for communication errors and a transmission error occurred. (Error code 0374 will not occur in this case.)	0x80: Slice I/O	Node address (Hex)	Verify that the Unit is connected properly. Check whether there is excessive noise in the surroundings.	Yes
0376	Slave duplication error Cause: A Slave duplication error occurred.	0x80: Slice I/O	Node address (Hex)	Verify that the Unit is connected properly and turn the power ON again.	No
0378	I/O size error	0x00	0x00	Verify that the Unit is connected properly and turn the power ON again.	No
0379	Slice configuration error	0x00	0x00	Verify that the Unit is connected properly and turn the power ON again.	No

## 4-4 Maintenance

This section describes the routine cleaning and inspection recommended as regular maintenance.

### 4-4-1 Cleaning

Clean the PROFIBUS Communication Unit regularly as described below in order to keep it in an optimum operating condition.

- Regularly wipe the Unit with a dry, soft cloth.
- If a spot cannot be removed with a dry cloth, dampen the cloth with a neutral cleaner, wring out the cloth and wipe the Unit.

 **Caution** Never use volatile solvents such as paint thinner, benzene or chemical wipes. These substances could damage the surface of the Unit.

### 4-4-2 Inspection

Be sure to inspect the system periodically to keep it in optimum operating condition. In general, inspect the system once or twice a year, but more frequently if the system is used in high temperature or high humidity environments or dirty/dusty conditions.

#### Inspection Equipment

Prepare the following equipment before inspecting the system.

#### Required Equipment

Philips type screwdriver, multimeter, alcohol, and a clean cloth.

#### Optional Test Equipment

Depending on system conditions, a synchroscope, oscilloscope, thermometer or hygrometer (to measure humidity) might be needed.

#### Inspection Procedure

Check the items in the following table and correct any that are below standard.

	Item	Standard	Equipment
Environmental conditions	Ambient temperature	0° C to 55° C	Thermometer
	Ambient humidity	10% to 90%	Hygrometer
	Dust/dirt accumulation	None	---
Installation	Are the units installed securely?	No looseness	---
	Are the communication connectors fully inserted?	No looseness	---
	Are the external wiring screws tight?	No looseness	---
	Are the connecting cables undamaged?	No damage	---



## 4-5 Replacing the Unit

### 4-5-1 Replacement Precautions

The PROFIBUS Communication Unit is a Network device. If the Unit is damaged, it will effect the entire Network, so always ensure repairs are undertaken immediately. It is recommended to have a spare PROFIBUS Communication Unit on hand so that repairs may be conducted quickly.

#### Replacement Precautions

Observe the following precautions when replacing the Unit.

- Always turn OFF the power before replacing the Unit.
- Ensure that the new Unit is not faulty.
- If a poor connection is suspected of causing the malfunction, clean the connectors using a clean, soft cloth and industrial-grade alcohol. Remove any lint or threads left from the cloth, and remount the Unit.
- When returning a faulty Unit for repair, always attach a detailed fault report to the Unit and return it to the nearest OMRON dealer.

- Note**
1. In order to prevent faulty operation be sure to turn off the power to all master and slave devices before replacing the Unit.
  2. When replacing the Unit, do not reconnect it to the Network before carrying out the procedures listed below.

### 4-5-2 Setting the Unit after Replacement

After replacing the Unit - before re-applying the power - set the Profibus station address number to the same value as the previous Unit.

After re-applying the power, the Profibus configuration settings will be automatically set by the Profibus Master. No user actions required.

When using one or more of the following Unit functions for the old Unit:

1. Table Registration Function, see Section 3-2-1 *Table Registration Function*
2. Backup Function, see Section 3-2-2 *Backup Function*
3. Automatic Restore Function, see Section 3-2-3 *Automatic Restore Function*

execute these operations again for the new Unit.

Re-connect it to the network, and restart operation.

# Appendix A

## PROFIBUS Technology

### A-1 Overview of PROFIBUS

PROFIBUS (PROcess FieldBUS) is an open fieldbus standard for a wide range of applications in manufacturing, processing and building automation. The Standard, EN 50170 (the Euronorm for field communication), to which PROFIBUS adheres, guarantees vendor independence and transparency of operation. It enables devices of various manufacturers to intercommunicate without having to make any special interface adaptations.

The PROFIBUS family comprises three mutually compatible versions:

- PROFIBUS FMS (for Fieldbus Message Specification) is the general-purpose solution for high-level extensive and complex communication tasks. Powerful services open up a wide range of applications and provide great flexibility.
- PROFIBUS DP (for Decentralized Periphery) is a variant optimized for high speed and low-cost interfacing. It is specially designed for communication between automation control systems and distributed I/O at the device level.
- PROFIBUS PA (for Process Automation) is a variant which permits sensors and actuators to be connected to one common bus even in areas where intrinsically safe products are required. It permits data and power to be supplied over the bus using 2-wire technology according to the international standard IEC 1158-2.

PROFIBUS DP and PROFIBUS FMS use the same transmission technology and uniform bus access protocol. Consequently, both versions can be operated simultaneously on the same bus. FMS field devices, however, cannot be controlled by DP masters and vice versa.

**⚠ Caution** It is not possible to exchange one of these family members by another family member. This will cause faulty operation.

### A-2 PROFIBUS Communication Protocol

In general, the PROFIBUS communication protocol is based on the Open System Interconnection (OSI) reference model in accordance with the international standard ISO-7498 (see the following illustration). The model defines 7 layers of communication functions, three of which - layers 1, 2, and 7 - are used in PROFIBUS.

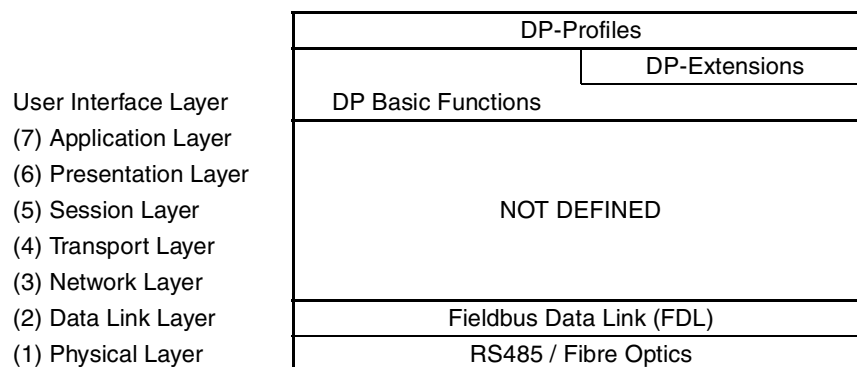

- Layer 1, the Physical Layer of this model, defines the physical transmission characteristics.
- Layer 2, the Data Link Layer of this model, defines the bus access protocol. This protocol also includes data security and the handling of transmission protocols and telegrams.
- Layer 7, the Application Layer of this model, defines the application functions. This Layer is only applicable to PROFIBUS FMS

In the rest of this Appendix, only PROFIBUS DP is considered.

PROFIBUS DP uses layers 1 and 2, and the user interface. Layers 3 to 7 are not defined for PROFIBUS DP. The User Interface Layer defines the interface functions for specific application areas, i.e. the PROFIBUS DP basic functions and communication profiles. This streamlined architecture ensures fast and efficient data transmission. The application functions which are available to the user, as well as the system and device behaviour of the various PROFIBUS DP device types, are specified in the user interface.

RS-485 transmission technology or fibre optics are available for transmission. RS-485 transmission is the most frequently used transmission technology. Its application area includes all areas in which high transmission speed and simple inexpensive installation are required. PROFIBUS modules are interconnected by single twisted-pair shielded copper wires.

The RS-485 transmission technology is very easy to handle. Installation of the twisted pair cable does not require expert knowledge. The bus structure permits addition and removal of devices or step-by-step commissioning of the system without influencing the other devices. Later expansions have no effect on devices which are already in operation.

Transmission speeds between 9.6 kbit/s and 12 Mbit/s can be selected as shown in the table below. One unique transmission speed must be selected for all devices on the bus when the system is commissioned.

Baud rate (kbit/s)	Distance / segment (m)	Baud rate (kbit/s)	Distance / segment (m)
9.6	1200	500	400
19.2	1200	1500	200
45.45	1200	3000	100
93.75	1200	6000	100
187.5	1000	12000	100

The maximum cable length values depend on the transmission speed and are based on type-A cable (see *Cable Type on page 25*). The length can be increased by the use of repeaters. However, it is not recommended to use more than three repeaters in series in a PROFIBUS network.

### **A-3 Device Types**

PROFIBUS distinguishes between master devices and slave devices.

Master devices determine the data communication on the bus. A Master can send messages without an external request, as long as it holds the bus access right (the token). Masters are also referred to as active devices in the PROFIBUS standard.

There are two types of master devices.

- A PROFIBUS DP Class 1 Master (DPM1) device is a central controller, which exchanges information with the decentralized devices (i.e. DP slaves) within a specified message cycle.
- PROFIBUS DP class 2 Master (DPM2) devices are programmers, configuration devices or operator panels. They are used during commissioning, for configuration of the DP system, or for operation and monitoring purposes.

Slave devices are peripheral devices. Typical slave devices include input/output devices, valves, drives, and measuring transmitters. They do not have bus access rights and they can only acknowledge received messages or send messages to the master when requested to do so. Slave devices are also called passive devices.

The GRT1-PRT is a PROFIBUS DP Slave device.

To enable the exchange of devices from different vendors, the user data has to have the same format. The PROFIBUS DP protocol does not define the format of user data, it is only responsible for the transmission of this data. The format of user data may be defined in so called profiles. Profiles can reduce engineering costs since the meaning of application-related parameters is specified precisely. Profiles have been defined for specific areas like drive technology, encoders, and for sensors / actuators.

## A-4 Bus Access Protocol

The PROFIBUS bus access protocol is implemented by OSI layer 2. This protocol also includes data security and the handling of the transmission protocols and messages.

The Medium Access Control (MAC) specifies the procedures which determine when a device is permitted to transmit data. A token passing procedure is used to handle the bus access between master devices, and a polling procedure is used to handle the communication between a master device and its assigned slave device(s).

The token passing procedure guarantees that the bus access right (the token) is assigned to each master within a precisely defined time frame. The token message, a special message for passing access rights from one master to the next master, must be passed around the logical token ring - once to each master - within a specified target rotation time. Each master executes this procedure automatically.

The polling or master-slave procedure permits the master, currently in possession of the token, to access its assigned slaves. The figure below shows a possible configuration. The configuration shows three active devices (masters) and six passive devices (slaves).

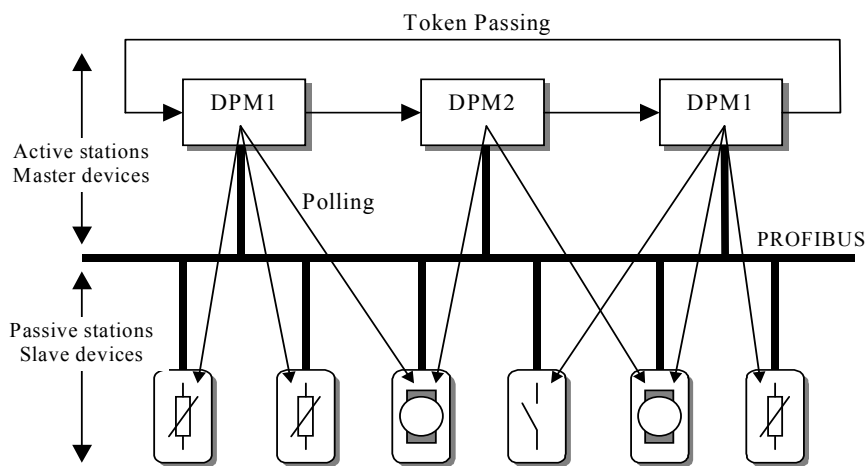

The three masters form a logical token ring. When an active device receives the token message, it can perform its master role for a certain period of time. During this time it can communicate with all assigned slave devices in a master-slave communication relationship, and a DPM2 master can take the initiative to communicate with DPM1 master devices in a master-master communication relationship.

In addition to logical peer-to-peer data transmission, PROFIBUS DP provides multi-peer communication (broadcast and multicast).

- Broadcast communication: a master device sends an unacknowledged message to all other devices (masters and slaves).
- Multicast communication: a master device sends an unacknowledged message to a predetermined group of devices (masters and slaves).

## A-5 Diagnostic functions

Extensive diagnostic functions defined in PROFIBUS DP enable the fast location of errors at slave devices. Diagnostic messages are transmitted over the bus and collected at the master. Three levels of diagnostic messages are defined:

- Messages indicating the general operational status of the whole device, e.g. over temperature, low voltage.
- Messages indicating an error in a specific I/O range of a device, e.g. an 8-bit output module.
- Messages indicating an error at a given input or output, e.g. short circuit on Output 5.

## A-6 Protection Mechanisms

PROFIBUS DP provides protection functions against parameterization errors or failure of the transmission equipment. Time monitoring is provided both at the master and the slave devices. The monitoring interval is specified when the system is configured.

The PROFIBUS DP Master monitors data transmission of each individual slave device with the Data-Control-Timer. This timer expires if response data is not correctly received from the slave within the monitoring interval. If the automatic error reaction (Auto-CLEAR) has been enabled, the PROFIBUS DP master exits its OPERATE state, switches the outputs of all assigned slaves to the fail-safe status and changes to the CLEAR state.

Slave devices use a watchdog to detect failures of the master or the bus. If no data exchange with the master occurs within the set watchdog time interval, the slave automatically switches its outputs to the fail-safe mode.

Also, access protection is provided for the inputs and outputs of the slaves operating in multi-master systems. Only authorized masters can access their slaves.

## A-7 Network Operation Modes

PROFIBUS DP distinguishes four different network operation modes:

- **OFFLINE:** Communication with all PROFIBUS DP participants (masters and slaves) is stopped. The Master ceases to access the PROFIBUS network.
- **STOP:** Communication between the master and its slaves is stopped. Only communication between the master and other masters is possible.
- **CLEAR:** The master tries to set parameters, check the configuration, and perform data exchange with its associated slaves. Data exchange involves reading the inputs of the PROFIBUS DP slaves and writing zeros to the outputs of the slaves.
- **OPERATE:** The master exchanges I/O data with its assigned slaves. Also, the master cyclically sends its own status to all assigned PROFIBUS DP slaves using a broadcast message.

The PROFIBUS DP Master Unit will always be in one of these four modes. Mode transitions will be performed via intermediate modes. For example, a mode transition from OFF-LINE to OPERATE, will be performed as OFF-LINE →STOP →CLEAR →OPERATE.

If an error occurs during the data exchange phase of the master, the 'Auto-CLEAR' function determines the subsequent actions. If this function has been disabled, the master remains in the OPERATE mode. If the function has been enabled, the master automatically changes the network to the CLEAR mode, in which the outputs of the assigned PROFIBUS DP slaves are switched to zero, i.e. the 'fail-safe' state. The master continues to read the inputs of the slaves.

## A-8 Configuring the PROFIBUS DP Master

In order to operate a PROFIBUS network, each master in the network needs to be configured. This process of PROFIBUS master configuration involves

- setting up the network topology, i.e. assigning the slave devices to the master device,
- defining the parameterization data, which the master will send to each of the slave devices, before process data exchange can commence
- defining the configuration data, i.e. defining the process data, which will be exchanged,
- setting up the bus parameters, which define the baud rate and the bus timing parameters.
- downloading the configuration setup to the master device.

The configuration process is usually facilitated by a special Computer based program, often referred to as a configurator. The configurator requires special configuration files, defining the configuration options for each device, which is to participate in data exchange. The files must be provided by the manufacturer of the device.

Two types of configuration technology exist:

- Configuration technology based on FDT/DTM technology
- Configuration technology based on GSD-files

## A-9 FDT/DTM Technology

The FDT/DTM concept specifies the interfaces between the engineering systems called Field Device Tools (FDT), and the device-specific software components called Device Type Managers (DTM). FDT/DTM is the most recent advancement in Configurators.

The FDT/DTM concept separates the device dependent functionality (which is in the DTM) from the application. It provides separate interfaces for device configuration, monitoring and maintenance solutions, which before largely depended on the manufacturer of the application. Because of this concept, any type of network can be configured and accessed, provided the appropriate DTMs are available.

A FDT container application facilitates configuration of network devices and parameterizing and/or manipulating their operational modes. All device dependent functionality is concentrated in the DTM.

FDT container applications can be stand-alone tools, or can be part of other engineering tools such web browsers providing FDT interfaces. Since FDT standardizes the interfaces, it allows devices from different manufacturers to be integrated in any automation system, regardless of the fieldbus system.

Cx-Profibus is an example of a FDT container application.

DTMs are provided by the manufacturer of the device. A DTM is comparable to a printer driver, which allows interactive configuration and diagnostics. The DTM provides not only the configuration, manipulation and monitoring functions for a device including the user interface functions, it also provides the connection technology to the device.

A DTM provides all the options for configuration and monitoring of a device, which it can present to the user through its own user interface. The user interface for a DTM is provided using ActiveX windows. In general multi-language user interface windows, including DTM specific Help files are supported by the DTM.

In general, a device configuration DTM is accompanied by a communication DTM. This specific DTM facilitates device specific communication, e.g. for downloading a configuration to a PROFIBUS DP Master Unit and/or for retrieving monitoring information from PROFIBUS DP Master Unit. It may incorporate the specific communication protocol, or rely on other available drivers.

## A-10 GSD file Technology

The older and most commonly used configuration technology is the based on GSD files (General Slave Data file). A GSD file is a text file, containing the characteristic features and configuration options of a device. The device data base file of each device is loaded in the configurator and downloaded to the master device.

GSD files are usually supplied with a Unit, or can be downloaded from the Internet, either from the manufacturer's site, or from the GSD library of PROFIBUS International at <http://www.profibus.com>.

OMRON provides a GSD file for the GRT1-PRT, to facilitate configuration for third-party PROFIBUS Master devices.

The GSD files are prepared individually by the vendor for each type of device, according to a fixed format. Some parameters are mandatory, some have a default value and some are optional.

When comparing the two configuration technologies, a GSD file only provides information on the device characteristics and configuration options. It has no GUI of its own, nor can it connect to the device itself. A GSD file always requires a separate configurator program to interpret the data. In the FDT/DTM concept all these device related functions are included in the DTM. The DTM can be executed from any program, which provides FDT interfaces.



# Appendix B

## Slave Diagnostics Message

The PROFIBUS Communication Unit supports diagnostics to allow the user system to automatically determine problems, which can occur in the SmartSlice I/O system. The PROFIBUS Diagnostics consists of standard diagnostics and possibly extended diagnostics.

### B-1 Standard Diagnostics

#### Slave Diagnostics Byte 1: Station Status 1

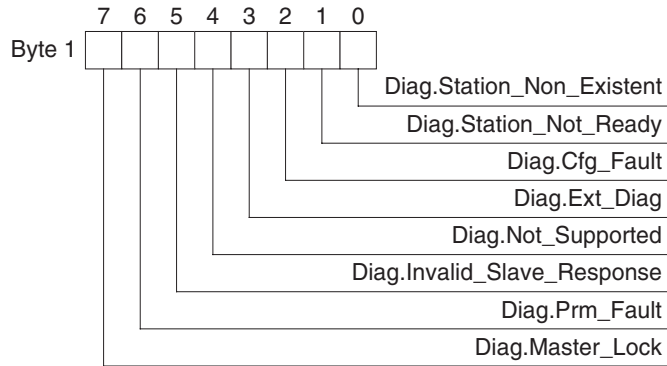

Bit	Name	Description
00	Diag.Station_Non_Existent	This bit is set by the Master Unit if the Unit does not respond to any of the request messages sent by the master. If this bit is set the diagnostic bits contains the state of the last diagnostic message or the initial value. The slave device sets this bit to zero in case of a correct response.
01	Diag.Station_Not_Ready	This bit indicates that the Unit is not yet ready for data transfer. This also may be caused by a SmartSlice Bus failure during start-up.
02	Diag.Cfg_Fault	Set by the Unit, this bit indicates that the last received configuration data from the Master Unit is rejected. The configuration data in the slave device differ from the configuration sent by the Master Unit.
03	Diag.Ext_Diag	This bit indicates that the diagnostics message returned by the Unit contains extended diagnostics, i.e. it contains more than the mandatory 6 bytes.
04	Diag.Not_Supported	In case the Master Unit sent a message to the Unit, which is not supported, this bit will be set.
05	Diag.Invalid_Slave_Response	This bit is set by the Master Unit if the Unit has returned an invalid response to a Master request message. The slave device will set this bit to 0.
06	Diag.Prm_Fault	Set by the Unit, this bit indicates that the last received parameter data from the Master Unit has been rejected. The parameter data in the Unit differ from the parameter sent by the Master Unit.
07	Diag.Master_Lock	This bit indicates that the Unit has been parameterized by another master. The bit is set by the Master Unit, if the address in byte 4 differs from 255 and from the Master Unit's own address. The Unit sets this bit to zero.



**Slave Diagnostics Byte 2: Station Status 2**

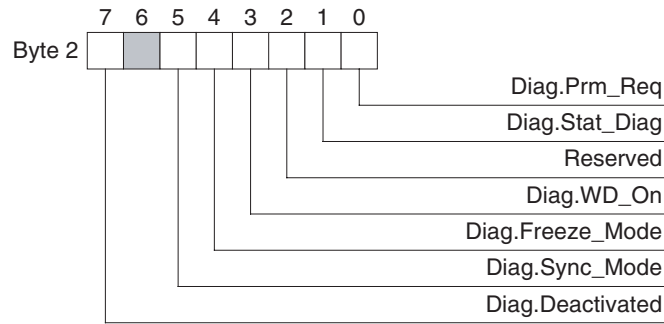

Bit	Name	Description
00	Diag.Prm_Req	This bit is set by the Unit and indicates that it needs to be (re-)parameterized. The Unit is not in Data_Exchange with the Master Unit. The bit remains on as long as it has not been parameterized successfully.
01	Diag.Stat_Diag	This bit indicates static diagnostics at the Unit. The Master Unit will repeatedly request diagnostics data. As long as this bit is set, Data_Exchange with the Master Unit is not being performed.
02	Reserved	This bit is reserved and always set to 1 by the Unit.
03	Diag.WD_On	If the watchdog has been enabled at the slave device (through the appropriate setting in the parameterization message) this bit will be set.
04	Diag.Freeze_Mode	If the Unit has been set to the Freeze mode, using the global command, this bit will be set to on. The bit will be set to off, if an Unfreeze command has been received.
05	Diag.Sync_Mode	If the Unit has been set to the Sync mode, using the global command, this bit will be set to on. The bit will be set to off, if an Unsync command has been received.
06	Reserved	This bit is reserved.
07	Diag.Deactivated	This bit is set by the Master Unit, indicating that the Unit has been disabled (i.e. using the STOP FINS command). The Unit is allocated to the Master Unit, but removed from cyclic processing.

**Slave Diagnostics Byte 3: Station Status 3**

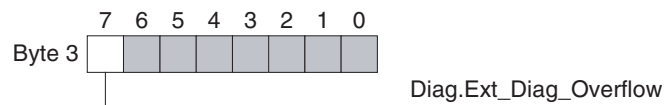

Bit	Name	Description
00 ~ 06	Reserved	These bits are reserved and always set to 0 by the slave device.
07	Diag.Ext_Diag_Overflow	If set, this bit indicates that there exists more diagnostic information than specified in Ext_Diag_Data. This bit will - for example - be set if the Unit has more diagnostics available than it can enter in its send buffer. This bit will also be set if the Master Unit receives more diagnostic information than it can enter in its diagnostic buffer.

**Slave Diagnostics Byte 4: Master PROFIBUS Address**

This byte contains the PROFIBUS address of the Master Unit, which parameterized the slave. If the slave is not parameterized correctly, the byte contains FF (Hex) or 255 (Decimal).

## Slave Diagnostics Bytes 5 to 6: Ident Number

Slave Diagnostics Bytes 5 and 6 contain the PROFIBUS Ident Number of the slave device. The Ident number uniquely identifies the type of device. For the GRT1-PRT PROFIBUS DPV1 slave the Ident number is 098F (Hex).

## B-2 Extended Diagnostics

### Module Diagnostics

The Module Diagnostics will indicate whether or not SmartSlice I/O Units have communication or configuration errors related to the Unit.

	7	6	5	4	3	2	1	0		
Byte 7	Header byte = 4A (Hex)									
Byte 8	7	6	5	4	3	2	1	0	SmartSlice Slot 1 ~ 7, COM Status (0)	
Byte 9	15	14	13	12	11	10	9	8	SmartSlice Slots 8 ~ 15	
Byte 10	23	22	21	20	19	18	17	16	SmartSlice Slots 16 ~ 23	
Byte 11	31	30	29	28	27	26	25	24	SmartSlice Slots 24 ~ 31	
Byte 12	39	38	37	36	35	34	33	32	SmartSlice Slots 32 ~ 39	
Byte 13	47	46	45	44	43	42	41	40	SmartSlice Slots 40 ~ 47	
Byte 14	55	54	53	52	51	50	49	48	SmartSlice Slots 48 ~ 55	
Byte 15	63	62	61	60	59	58	57	56	SmartSlice Slots 56 ~ 63	
Byte 16	Fixed to 0								64	SmartSlice Slot 64

### Module Diagnostics bytes

Bit	Name	Description
00	COM Status	When set, this bit indicates that there is Diagnostics information pending related to the COM status.
01 - 64	Module Diagnostics	When set, this bit indicates that there is Diagnostics information pending related to the corresponding SmartSlice slot.

**Module Status Diagnostics**

The Module Status Diagnostics will indicate the detailed status of the SmartSlice I/O Units.

	7	6	5	4	3	2	1	0	
Byte 17	Header byte = 14 (Hex)								
Byte 18	Status Type = 82 (Hex)								
Byte 19	Slot Number = 00 (Hex)								
Byte 20	Specifier = 00 (Hex)								
Byte 21	04	03	02	01	SmartSlice Slot 1 ~ 4				
Byte 22	08	07	06	05	SmartSlice Slot 5 ~ 8				
Byte 23	12	11	10	09	SmartSlice Slot 9 ~ 12				
Byte 24	16	15	14	13	SmartSlice Slot 13 ~ 16				
Byte 25	20	19	18	17	SmartSlice Slot 17 ~ 20				
Byte 26	24	23	22	21	SmartSlice Slot 21 ~ 24				
Byte 27	28	27	26	25	SmartSlice Slot 25 ~ 28				
Byte 28	32	31	30	29	SmartSlice Slot 29 ~ 32				
Byte 29	36	35	34	33	SmartSlice Slot 33 ~ 36				
Byte 30	40	39	38	37	SmartSlice Slot 37 ~ 40				
Byte 31	44	43	42	41	SmartSlice Slot 41 ~ 44				
Byte 32	48	47	46	45	SmartSlice Slot 45 ~ 48				
Byte 33	52	51	50	49	SmartSlice Slot 49 ~ 52				
Byte 34	56	55	54	53	SmartSlice Slot 53 ~ 56				
Byte 35	60	59	58	57	SmartSlice Slot 57 ~ 60				
Byte 36	64	63	62	61	SmartSlice Slot 61 ~ 64				

00	Data valid
01	Reserved
10	Wrong SmartSlice / Data invalid
11	No SmartSlice / Data invalid

**Note** If two or more SmartSlice I/O Units do not match with the PROFIBUS I/O configuration sent by the PROFIBUS Master Unit, the diagnostics message will only contain the error flags of the first mismatching SmartSlice I/O Unit.

# Appendix C

## Explicit Messages

Explicit messages sent from the Master Unit to a GRT1 Series PROFIBUS Communication Unit can be used to read or write any parameter of a specified GRT1 Series PROFIBUS Communication Unit.

The PROFIBUS Communication Units process the commands sent from the Master and then return responses.

### C-1 Basic Format of Explicit Messages

The basic format of each command and response is shown below.

#### Command Block

Destination station address	Service code	Class ID	Instance ID	Attribute ID	Data
-----------------------------	--------------	----------	-------------	--------------	------

#### Destination Station Address

The station address of the Unit that is sending the explicit messages (commands) is specified as a single-byte hexadecimal.

#### Service Code, Class ID, Instance ID, Attribute ID

The parameters used for specifying the command, processing object, and processing content.

**Note** The number of bytes designated for Class ID, Instance ID, and Attribute ID depend on the Master Unit. When sent from an OMRON Master, the Class ID and Instance ID are 2 bytes (4 digits), and Attribute ID is 1 byte (2 digits).

#### Data

Data is not required when the read command is used.

#### Response Block

##### Normal Response Block

Number of bytes received	Source station address	Service code	Data
--------------------------	------------------------	--------------	------

##### Error Response Block

Number of bytes received: 0004 Hex (fixed)	Source station address	Service code	Error code
---	------------------------	--------------	------------

#### Number of Bytes Received

The number of bytes received from the source station address is returned in hexadecimal. When an error response is returned for an explicit message, the number of bytes is always 0004 Hex.

#### Source Station Address

The station address of the station from which the command was sent is returned in hexadecimal.

**Service Code**

For normal completion, the value when the leftmost bit of the service code specified in the command turns ON is stored as shown in the following table.

Function	Command service code	Response service code
Write data	10 Hex	90 Hex
Read data	0E Hex	8E Hex
Reset	05 Hex	85 Hex
Save	16 Hex	96 Hex

When an error response is returned for an explicit message, the value is always 94 Hex.

**Data**

Read data is included only when a read command is executed.

**Error Codes**

The explicit message error code. For details, refer to the list of error codes in the following table.

**List of Error Codes**

Response code	Error name	Cause
08FF	Service not supported	The Service code is incorrect.
09FF	Invalid Attribute value	The specified Attribute value is not supported. The data written was outside valid range.
16FF	Object does not exist	The specified Instance ID is not supported.
15FF	Too much data	The data is larger than the specified size.
13FF	Not enough data	The data is smaller than the specified size.
0CFF	Object state conflict	The specified command cannot be executed due to an internal error.
20FF	Invalid parameter	The specified operation command data is not supported.
0EFF	Attribute not settable	An Attribute ID supported only for reading has been executed for a write service code.
10FF	Device state conflict	The specified command cannot be executed due to an internal error.
14FF	Attribute not supported	The specified Attribute is not supported.
19FF	Store operation failure	The data cannot be stored in memory.
2AFF	Group 2 only server general failure	The specified command or Attribute is not supported or the Attribute was not set.

## C-2 Explicit Messages Common to All Slaves

### Alarm Information Read

Explicit message	Read/write	Function	Command					Response
			Service code	Class ID	Instance ID	Attribute ID	Data size	
Alarm Information Read	Read	Reads the SmartSlice I/O Unit's alarm data.	0E Hex	9C Hex	01 Hex	73 Hex	-	32 bytes (See note.)

**Note** The following tables show the alarm data details.

Word offset	Bit			
	15	12	11	8 7 4 3 0
+0	SmartSlice I/O Node #4	SmartSlice I/O Node #3	SmartSlice I/O Node #2	SmartSlice I/O Node #1
+1	SmartSlice I/O Node #8	SmartSlice I/O Node #7	SmartSlice I/O Node #6	SmartSlice I/O Node #5
+2	SmartSlice I/O Node #12	SmartSlice I/O Node #11	SmartSlice I/O Node #10	SmartSlice I/O Node #9
:				
+13	SmartSlice I/O Node #56	SmartSlice I/O Node #55	SmartSlice I/O Node #54	SmartSlice I/O Node #53
+14	SmartSlice I/O Node #60	SmartSlice I/O Node #59	SmartSlice I/O Node #58	SmartSlice I/O Node #57
+15	SmartSlice I/O Node #64	SmartSlice I/O Node #63	SmartSlice I/O Node #62	SmartSlice I/O Node #61

The 4 bits allocated to each SmartSlice I/O Node have the following functions:

Bit 0	Warning (Minor error)
Bit 1	Alarm (Major error)
Bit 2	Reserved
Bit 3	Reserved

**Note** The Warning/Alarm details depend on the Communication Unit. Refer to the Unit's operation manual.

### C-3 Using Explicit Messages

The following example shows how to use explicit messages with a PROFIBUS Communication Unit connected to a CJ1W-PRM21 Profibus Master Unit.

Example: Sending a “Unit Maintenance Present Value Read” command to the PROFIBUS Communication Unit.

**Example: PROFIBUS Master Unit’s station address: 05**

**Unit number: 0**

**Unit address: 11 Hex**

**GRT1-PRT Communication Unit’s station address: 65**

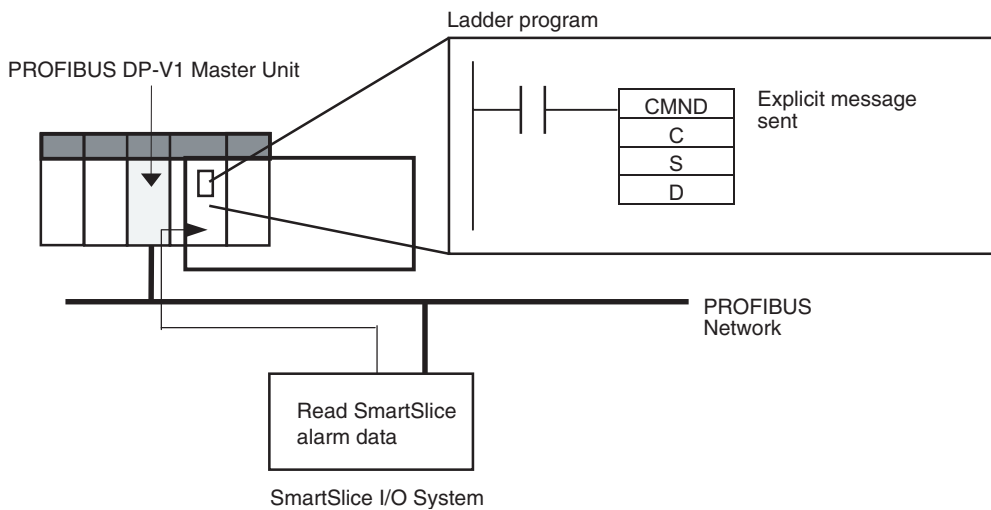

#### Operation

Reads the Alarm data of the connected SmartSlice I/O Unit from the PROFIBUS Communication Unit.

The data is read using the EXPLICIT MESSAGE SEND command (2801).

The command data is written in words starting from D01000 in the PLC and the response data is stored in words starting from D02000.

If the command does not end normally, the end code is stored in D00006 and the send command is re-executed.

**Note** The maximum length of the EXPLICIT MESSAGE SEND command (2801) when used for sending data over PROFIBUS is limited to 1004 bytes.

**Command Details**

- [CMND S      D      C]
- S: D01000
- D (first response word): D02000
- C: D00000

Contents of S

Address	Contents (Hex)	Meaning
D01000	28 01	Command code
D01001	41 0E	PROFIBUS Communication Unit's station address: 65 Service code: 0E Hex
D01002	00 9C	Class ID: 009C Hex
D01003	00 01	Instance ID: 0001 Hex
D01004	73 **	Attribute ID: 73 ** Hex (Set any value for the blank boxes.)

Contents of C

Address	Contents (Hex)	Meaning
D00000	00 09	Number of bytes of command data
D00001	00 2A	Number of bytes of response data
D00002	00 00	Destination PROFIBUS Master Unit's network address: 0
D00003	00 11	Destination PROFIBUS Master Unit's unit address: 11 Hex
D00004	00 00	Response required Communication port number: 0 Number of retries: 0
D00005	00 3C	Response monitoring time: 6 s

**Response**

Contents of D

Address	Contents (Hex)	Meaning
D02000	28 01	
D02001	00 00	
D02002	00 24	
D02003	41 8E	Response source station address: 65 (41 Hex) Normal completion: 8E Hex
D02004 to D02020	20 00	Number of slave alarm data: 32 (20 Hex) Status of slave #4, Status of slave #3 (2 bits each)
D02005	00 00	Status of slave #8, slave #7, slave #1, slave #2 (2 bits each)
D02006 to D02020	...	(continue)





# Index

## A

About  
Manual, vii  
A-line, 15  
Auto-CLEAR, 74  
Automatic restore, 38

## B

Backup function, 38  
Basic Operating Procedure, 9  
Baud rate, 15  
B-line, 15  
Bus connector, 27  
Bus termination  
See Wiring

## C

Cable  
see Wiring  
changing present values, xv  
Configuring the PROFIBUS-DP Master, 74  
Connecting SmartSlice I/O Units, 18  
Connector, 15  
Cx-Profibus, 7

## D

Declaration of Conformity, xviii  
Device DTM, 75  
Diagnostic functions, 73  
Diagnostics, 73  
Diagnostics Update Delay, 45  
DIP switches, 14  
ADR switch, 14  
BACK switch, 14  
REGS switch, 14  
Downloading the configuration, 8

## E

EMC directive, xvii  
EN50170, 15  
Error history, 41  
Error on Cyclic Data Exchange, 44

## F

Fail-safe, 74  
FALS instruction, xiv  
FDT/DTM

Communication DTM, 75  
Device DTM, 75  
DTM versus GSD file, 75  
FDT Container application, 75  
FDT/DTM Concept, 75  
FINS, 44

## G-H

Generic Slave DTM  
Extensions  
Configuration convention, 44  
Diagnostics Update Delay, 45  
Error on Cyclic Data Exchange, 44  
GRT1-PRT  
Automatic restore, 38  
Backup function, 38  
Configuration, 42  
I/O Data mapping, 51  
Using the GSD File, 43  
DIP switches, 14  
Error history, 41  
Features, 3  
Functional Specifications, 5  
I/O allocation, 33  
I/O Data exchange, 4  
Installation, 16  
Installing a Unit, 17  
Messaging services, 4  
Monitoring, 52  
Online replacement of I/O units, 40  
Power connector, 15  
PROFIBUS connector, 15  
Protocol Specification, 6  
Removing a Unit, 17  
Specifications, 5  
Station address  
Rotary switches, 13  
System configuration, 4  
Table comparison, 37  
Table registration, 36  
GRT1-PRT Configuration  
Features, 7  
Setup, 42  
Using the GSD File, 8  
GRT1-PRT DTM  
Comparing data, 47  
Diagnostics Update Delay, 45  
Downloading data, 47  
Editing SmartSlice I/O units, 47  
Error on Cyclic Data Exchange, 44  
I/O module tab  
Selecting I/O configuration, 45  
Installation  
Procedure, 28  
Requirements, 28

- Installation requirements, 28
- Parameter area tab, 43
  - Auto-Clear, 44
  - FINS fragment length, 44
  - Station address, 43
  - Watchdog control setting, 43
- Resetting the unit, 48
- Uploading data, 47
- Using online functions, 47
- GRT1-PRT I/O module tab, 45
- GRT1-PRT Specifications
  - Environment, 5
  - External dimensions, 7
  - Front case, 5
  - Installation, 5
  - PROFIBUS services, 6
  - SmartSlice I/O system, 5
- GRT1-Series
  - Overview, 2
  - SmartSlice I/O Units, 2
- GSD file
  - DTM versus GSD file, 75
  - GSD file technology, 75

## I

- I/O data allocation, 33
- I/O data sizes, 35
- Table comparison, 37
- Table registration, 36
- Installation
  - DIN Rail, 16
  - Handling precautions, 16

## L-M

- LED indicators
  - Specifications, 12
- Low voltage directive, xvii
- Maintenance, 69
  - Cleaning, 69
  - Inspection, 69
    - Equipment, 69
    - Procedure, 69
- Manual
  - About, vii
  - Revision history, 91
- Master devices
  - See* PROFIBUS, Master
- Master DTM
  - Configuration, 74
- Medium Access Control, 73

## N

- Network
  - Monitoring, 52
  - Operation, 52
- Network operation modes
  - CLEAR mode, 74
  - OFFLINE mode, 74
  - OPERATE mode, 74
  - STOP mode, 74
- Network structure, 24
  - Linear bus topology, 24
  - Repeaters, 24
  - Tree topology, 24

## O-P

- OMRON
  - Copyright notice, iv
- Online replacement, 40
- Operating the Network, 52
- Operation modes
  - See* Network Operation modes, 74
- OSI reference model, 71
  - Layer 1, Physical Layer, 71
  - Layer 2, Data Link Layer, 71
  - Layer 7, Application Layer, 71
- outputs
  - precautions, xv
- Polling procedure, 73
- Power supply errors, 61
- Precautions
  - Application, xvi
  - General, xiv
  - Operating Environment, xv
  - Safety, xiv
- PROFIBUS
  - Explicit messages, 81
  - Master
    - Class 1 Master (DPM1), 72
    - Class 2 Master (DPM2), 72
  - Network
    - Operational modes, 74
    - PROFIBUS-DP, Decentralized Periphery, 71
    - PROFIBUS-PA, Process Automation, 71
    - Protocol Specification, 6
- Protection mechanism
  - Master Unit, 74
  - Monitoring Time, 74
  - Slave device, 74

## R

- refreshing

data, xv  
Rotary switches, 13  
RS-485  
  Cable length, 72  
  Cable Type, 25  
  *See also* Wiring

Bus connector, 27  
Bus termination, 26  
  Inductors, 26  
  Resistors, 26  
Cable length, 72  
Cable shield connection, 27

## **S**

Safety Precautions, xiv  
Setup  
  GRT1-PRT Configuration, 42  
Shock resistance, 5  
Slave devices, 72  
Slave diagnostics  
  Extended data  
    Channel related, 80  
    Device related, 77, 79  
    Module related, 79  
SmartSlice I/O Unit errors, 62  
SmartSlice I/O Units  
  Online replacement, 40  
  Troubleshooting, 62, 64

## **T**

Table comparison, 37  
Table registration, 36  
Token passing, 73  
Trademarks, iv  
transferring I/O memory data, xv  
transferring I/O memory files, xv  
Transmission medium  
  RS-485, 72  
Troubleshooting  
  GRT1-PRT, SmartSlice I/O Units, 60  
  Power supply errors, 61  
  PROFIBUS errors, 63  
  SmartSlice I/O Communication, 64  
  SmartSlice I/O Unit errors, 62  
  Unit system errors, 62  
  Using LED indicators, 60

## **U**

Unit replacement, 70  
  Precautions, 70  
  Unit setup, 70  
Unit system errors, 62

## **V-W**

Vibration resistance, 5  
Wiring



## Revision History

A manual revision code appears as a suffix to the catalog number on the front cover of the manual.

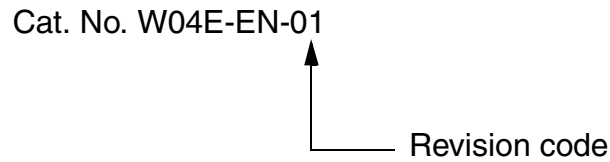

The following table outlines the changes made to the manual during each revision. The page numbers of a revision refer to the previous version.

Revision Code	Date	Revised Content
01	April 24, 2006	Initial version.
02	September 4, 2006	Page xiv: Updated Safety Precaution section. Page xvii: Added precaution bullet on foreign object damage when wiring. Page 54: Added note on use of monitoring DTM.
03	November 27, 2006	Page 2: Removed model table and added manual reference. Page 4: Removed non-supported features. Page 16: Added note to bottom of page. Page 22: Removed power consumption table and added manual reference. Page 23: Removed current consumption table and added manual reference. Page 57: Updated text on third bullet and removed Note 1. Page 58: Corrected $T_{MAX}$ calculation formula. Page 58: Moved note at the bottom to next page. Page 59: Improved IO Refresh timing table. Page 59: Removed formula for $T_{SL}$ . Page 59: Removed formula for $T_{SL-CI}$ and $T_{SL-CO}$ . Page 59: Removed formula for $T_{SL-IN}$ and $T_{SL-OUT}$ . Page 59: Added examples for processing time calculation. Page 65: Added Note reference to PROFIBUS Errors table. Page 65: Reformatted PROFIBUS Errors table. Page 66: Added note and renumbered notes. Page 66: Updated LED indicator images and text. Page 82: Added caption Reserved to bottom of image. Page 82: Added note on I/O configuration mismatch error flags.

