

JUSP-NS600

# Indexer unit

## Smart and simple positioning solution.

- No programming languages are required. Connects directly to the Sigma-II series drive
- Allows serial network control and discrete I/O control
- Servo axis set-up, actuation and monitoring
- 128 indexing programmed moves
- Refined methods and functions for smart control like program tables or position and speed tables
- Up to 16 servos can be connected via serial network
- With SigmaWin+ the system can be easily configured



## System configuration

### Using serial communications



CJ1/CS1 series Host controller

Controls 16 axes through RS-485/RS-422

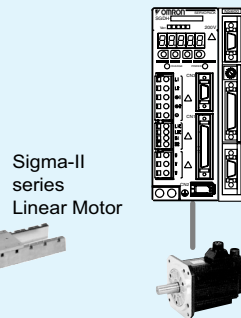
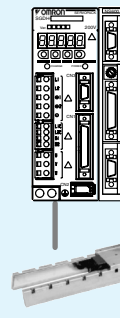
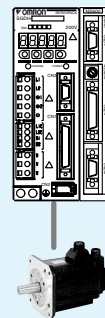
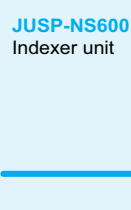
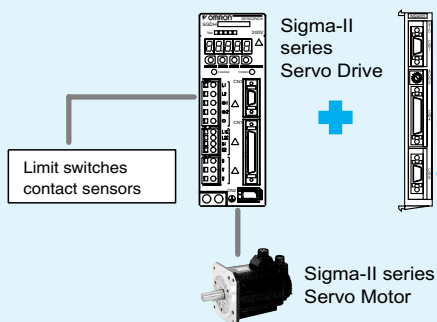

### Using digital I/O



Specifications

JUSP-NS600 - indexer unit

Item		Details	
Type		JUSP-NS600	
Applicable servo drive		All SGDh-□□□E SERVOPACKs	
Installation method		Mounted on the SGDh servo drive side: CN10.	
Basic specifications	Power supply method	Supplied from the servo drive control power supply	
	Power consumption	2.6 W	
Control specifications	Program table	Program table positioning by designating the starting step by the contact input (maximum 128 steps)	
	Serial communications	Serial commands in ASCII codes Communications specifications: RS422 / RS485 (maximum 50 m (164.0 ft)) RS232C (maximum 3 m (9.84 ft)) Connection: Multi-drop method (maximum 16 axes) Baud rate: 9600, 19200, 38400bps	
	Command table	Positioning by designating the command table by the contact input (maximum 128 points)	
	Zero-point return	3 types	
Other functions		External positioning, JOG speed table operation (maximum 16 speeds)	
I/O signals	Input	Servo drive	S-ON (Servo ON) P-OT (forward run prohibited), N-OT (reverse run prohibited) DEC (zero-point return deceleration LS) RTRG (external positioning signal)
		INDEXER module	MODE0/1 (mode signal) START/HOME (start signal / zero-point return execution) PGMRES/JOGP (program reset / motor forward rotation) SEL0/JOGN (program starting step designation / motor reverse rotation) SEL1 to SEL4 / JOG0 to JOG3 (program starting table selection / JOG speed table selection)
	Output	Servo drive	ALM (servo alarm) WARN (warning) BK (brake interlock) S-RDY (servo ready) ALO1, ALO2, ALO3 (alarm codes)
		INDEXER module	INPOSITION (positioning completed) POUT0 to POUT4 (programmable outputs)

Nomenclature

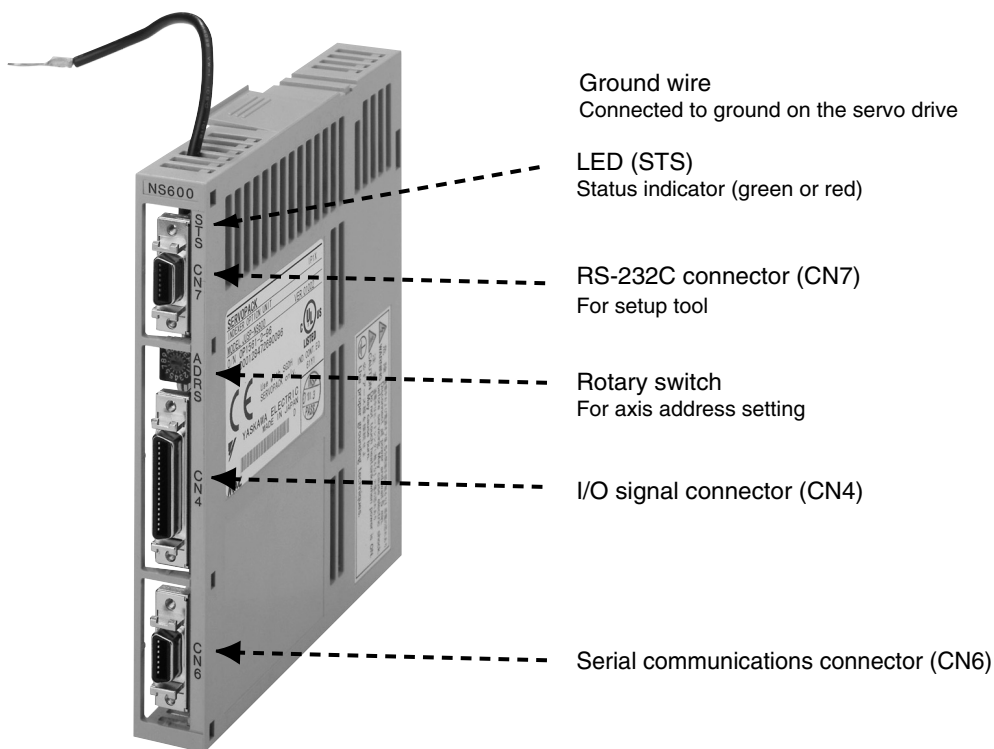

Dimensions

JUSP-NS600 - indexer unit

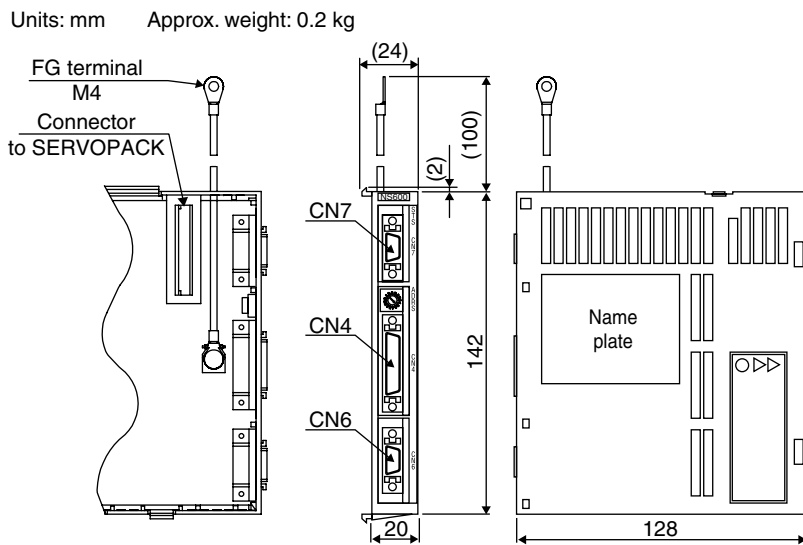

Installation

Standard connections

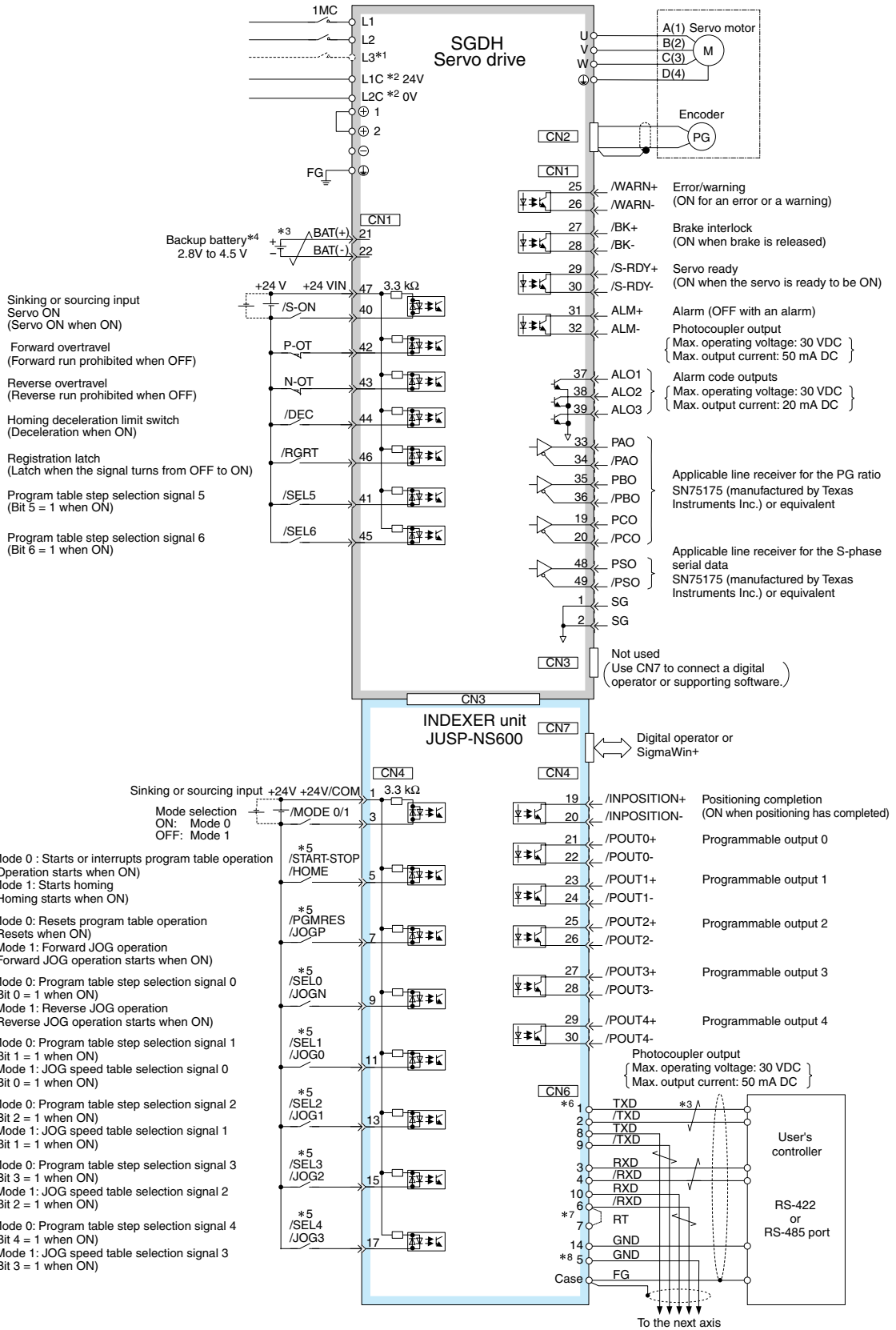

\*1: The L3 terminal is for specifications requiring a three-phase power supply.  
 \*2: The control power supply for 400 V-class servo drive is 24 VDC.  
 \*3: represents a twisted-pair cable.  
 \*4: Connect a backup battery when an absolute encoder is used and no battery is connected to CN8.

\*5: The signal on the first line is in mode 0, and the signal on the second line is in mode 1.  
 \*6: The wiring for CN6 shown here is full-duplex wiring for RS-422 or RS-485 communications.  
 \*7: Short-circuit RT and /RXD at the last axis.  
 \*8: Grounding for pin No.5 is available for hardware version 04 or later. The grounding for pin No.14 is shared with the other pins for hardware version 03 or earlier. The hardware version is shown in the VER. column of the nameplate located on the side of the device ( VER. □□□□ ).

**Note:** Connect the ground cable of indexer unit to the ground connector of the servo drive.

