

## Compact Magnetic Non-contact Safety Switches

**F3S-TGR-N□C**

*Magnetic Coded Non-contact switches are designed to inter-lock hinge, sliding or removal guard doors. All coded Non-contact switches have a LED for easy diagnosis.*

- Coded actuator for applications requiring anti tamper switches
- Non-contact = no abrasion = no particles
- Excellent coverage of mechanical tolerances
- Can operate behind stainless steel fittings
- Screw-hole covers support hygienic design (NMPC)
- Conforms to safety categories up to 4 acc. EN 954-1 and PDF-M acc. EN60947-5-3.

**Model Number Structure**

F3S-TGR-N□□C-□□-□□

1 2      3      4

**1. Type**

- L: Elongated Sensor
- S: Small Sensor for NLPC and NSMC
- M: Miniature Sensor

**2. Housing Material**

- P: Plastic Housing
- M: Stainless Steel Housing

**3: Contact configuration**

- 20: 2 Normally Closed Contacts (NC)
- 21: 2 Normally Closed Contacts (NC) + 1 Normally Open Contact (NO)

**4: Cable Length/connection**

- 02: 2m Cable
- 05: 5m Cable
- 10: 10m Cable
- M1J8: M12 male connector, 8pin

**4: Cable Length/connection for NMPC**

- 02: 2m Cable, cable exit to the left
- 05: 5m Cable, cable exit to the left
- 10: 10m Cable, cable exit to the left
- M1J8: M12 male connector, 8-pin, cable exit to the left

Ordering Information

Elongated Sensors	Type	Cable Connection	Contact Configuration
	F3S-TGR-NLPC-20-02	2 m pre-wired	2NC
	F3S-TGR-NLPC-20-05 *	5 m pre-wired	2NC
	F3S-TGR-NLPC-20-10	10 pre-wired	2NC
	F3S-TGR-NLPC-20-M1J8	M12, 8-pin	2NC
	F3S-TGR-NLPC-21-02	2 m pre-wired	2NC/1NO
	F3S-TGR-NLPC-21-05 *	5 m pre-wired	2NC/1NO
	F3S-TGR-NLPC-21-10	10 pre-wired	2NC/1NO
	F3S-TGR-NLPC-21-M1J8	M12, 8-pin	2NC/1NO

\*. Preferred stock items.



Small Sensor	Type	Cable Connection	Contact Configuration
	F3S-TGR-NSMC-20-02	2 m pre-wired	2NC
	F3S-TGR-NSMC-20-05 *	5 m pre-wired	2NC
	F3S-TGR-NSMC-20-10	10 pre-wired	2NC
	F3S-TGR-NSMC-20-M1J8	M12, 8-pin	2NC
	F3S-TGR-NSMC-21-02	2 m pre-wired	2NC/1NO
	F3S-TGR-NSMC-21-05 *	5 m pre-wired	2NC/1NO
	F3S-TGR-NSMC-21-10	10 pre-wired	2NC/1NO
	F3S-TGR-NSMC-21-M1J8	M12, 8-pin	2NC/1NO

\*. Preferred stock items.

Miniature Sensor	Type	Cable Connection	Contact Configuration
	F3S-TGR-NMPC-20-02	2m pre-wired	2NC
	F3S-TGR-NMPC-20-05 *	5m pre-wired	2NC
	F3S-TGR-NMPC-20-10	10m pre-wired	2NC
	F3S-TGR-NMPC-20-M1J8	M12, 8pin	2NC
	F3S-TGR-NMPC-21-02	2m pre-wired	2NC/1NO
	F3S-TGR-NMPC-21-05 *	5m pre-wired	2NC/1NO
	F3S-TGR-NMPC-21-10	10m pre-wired	2NC/1NO
	F3S-TGR-NMPC-21-M1J8	M12, 8pin	2NC/1NO

\*. Optional cable exit to the right is available for F3S-TGR-NMPC - types. Please contact your Omron distributor

Accessories

<b>Safety relay units</b>	G9SA 	G9SA-301 G9SA-501 G9SA-321-T075 G9SA-321-T15 G9SA-321-T30
	G9SB 	G9SB-2002-C G9SB-2002-A G9SB-200-B G9SB-200-D G9SB-3012-A G9SB-301-B G9SB-3012-C G9SB-301-D
	G9SX 	G9SX-BC202-R_ G9SX-AD322-T15-R_ G9SX-AD322-T150-R_ G9SX-ADA222-T15-R_ G9SX-ADA222-T150-R_
<b>Programmable Controllers</b>	Standalone controller 16 inputs	NE1A-SCPU01L
	Standalone controller 40 inputs	NE1A-SCPU02L
	Safety Network controller 16 inputs	NE1A-SCPU01-V1
	Safety Network controller 40 inputs	NE1A-SCPU02
	Safety input terminal	DST1-ID12SL-1
	Safety mixed terminal	DST1-MD16SL-1
<b>Cables 8-pin</b>	Safety mixed terminal (relay out)	DST1-MRD08SL-1
	2 m	F39-TGR-CVL-B-2-R
	5 m	F39-TGR-CVL-B-5-R
<b>T-Connector Connection cable</b>	10 m	F39-TGR-CVL-B-10-R
	for M12 connector - types	F39-TGR-NT
	2m M12-8pin, 2m	F39-TGR-CVL-N-2
	5m M12-8pin, 5m	F39-TGR-CVL-N-5
	10m M12-8pin, 10m	F39-TGR-CVL-N-10

## Specifications

## Mechanical Data

		Elongated Sensor	Small Sensor	Miniature Sensor
<b>Operating distance</b>	OFF → ON (Sao)	12mm Close		8mm Close
	ON → OFF (Sar)	17mm Open		12mm Open
<b>Actuator approach speed</b>	Min.	4mm/s		
	Max.	1000mm/s		
<b>Switching frequency</b>		1Hz		
<b>Operating temperature</b>		-25°C...+80°C	-25°C...+105°C	-25°C...+80°C
<b>Enclosure protection</b>	Flying lead M12 connector	IP67		
<b>Material</b>		Black Polycarbonate	Stainless Steel 316	Black Polyester
<b>Mounting bolts</b>		2 x M4 recommended		
<b>Tightening torque</b>		1Nm		0,8Nm
<b>Mounting position</b>		any		
<b>Mechanical life expectancy</b>		10.000.000 cycles		
<b>Electrical life expectancy</b>		1.000.000 cycles		
	De-rating Safety factor 2	2.000.000 cycles @ 24VDC/100mA		
<b>Cable diameter and material</b>		6mm PVC		

## Electrical Data

		Elongated Sensor	Small sensor	Miniature Sensor
<b>Power supply</b>		24VDC ±15%		
<b>Power consumption</b>	Max.	50mA		
<b>Switching current</b>	Min.	10mA @ 10VDC		
<b>Rated loads</b>	NC contacts	100mA @ 24VDC		
	NO contacts	100mA @ 24VDC		
<b>Insulation resistance</b>		100MΩ		
<b>Rated insulation voltage</b>		250VAC		
<b>Output type</b>		electronic output (potential-free optocoupler output)		

## Approved Standards

- EN standards certified by TÜV Rheinland
- EN 954-1
- EN 60204-1
- EN/IEC 60947-5-3
- UL 508, CSA C22.2
- BS 5304
- EN 1088-1 conformance

## Connection diagram

### Cable version

Pin No.	Signal name
red	+24 VDC
blue	GND
black	NC Channel 1, +
white	NC Channel 1, -
yellow	NC Channel 2, +
green	NC Channel 2, -
brown	NO Channel +
orange	NO Channel, -

### M12-Connector version

Pin No.	Signal name	Wire color (F39-TGR-SB4-CVLB)
2	+24 VDC	Brown
3	GND	Green
7	NC Channel 1, +	Blue
1	NC Channel 1, -	White
4	NC Channel 2, +	Yellow
6	NC Channel 2, -	Pink
5	NO Channel +	Grey
8	NO Channel, -	Red

## Operating characteristics

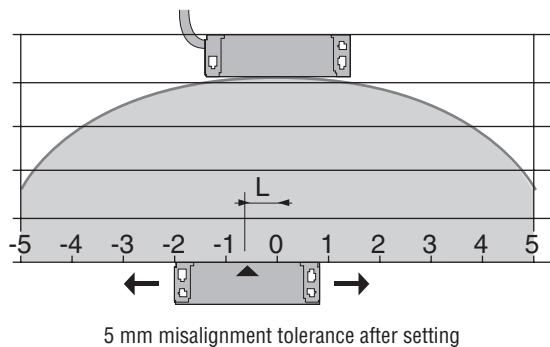

Dimensions

Elongated Sensor (Sensor/Actuator)

F3S-TGR-NLPC

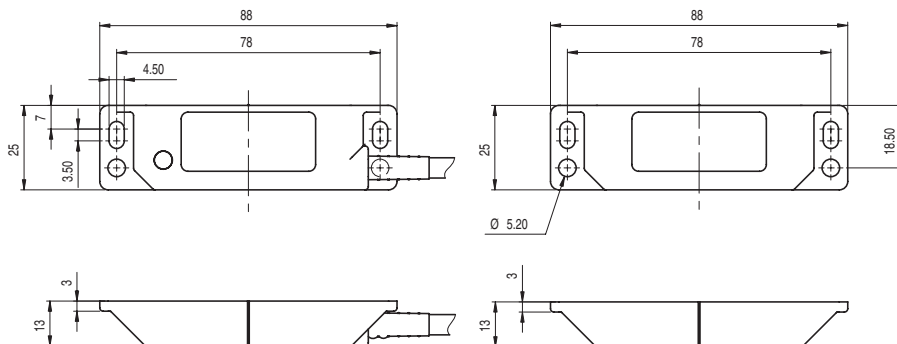

Small Sensor (Sensor/Actuator)

F3S-TGR-NSMC

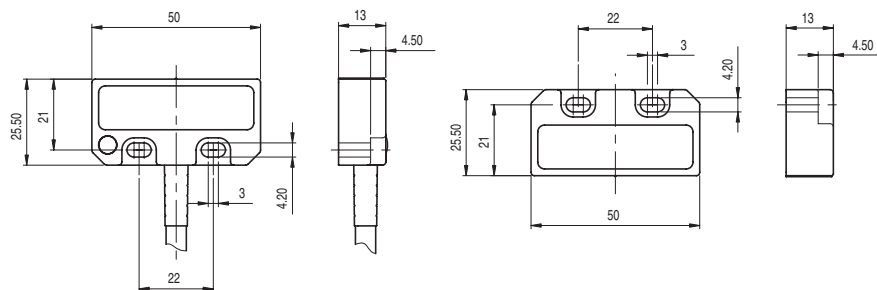

Miniature Sensor (Sensor/Actuator)

F3S-TGR-NMPC

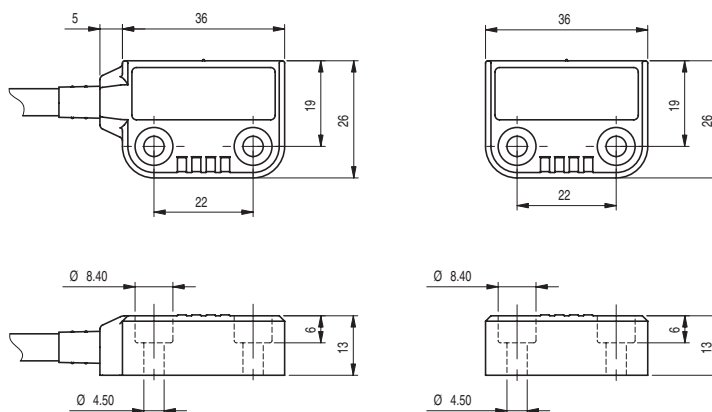

Wiring examples (Single head connection up to category 4 acc. EN954-1)

G9SA

Single Sensor Application with G9SA-301

(up to Safety Category 4 acc. EN954-1)

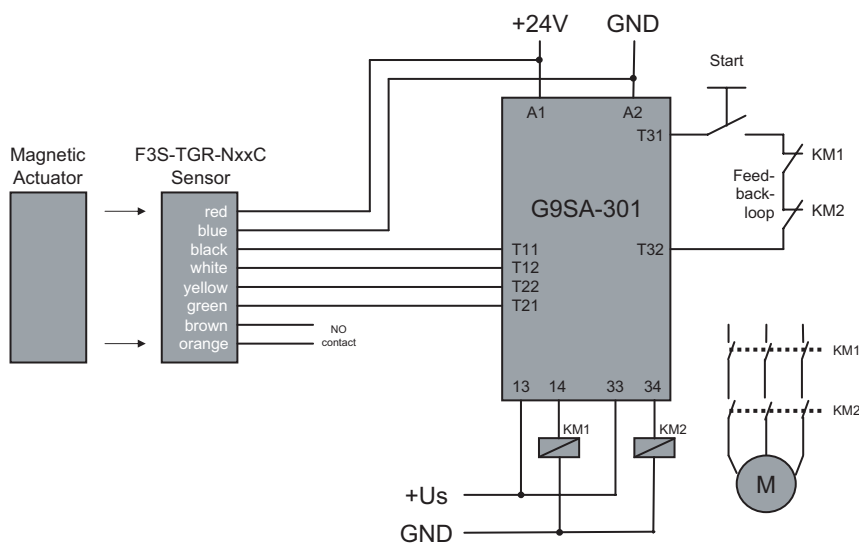

Series connection Application, up to 6 Sensors with G9SA-301

(up to Safety Category 3 acc. EN954-1)

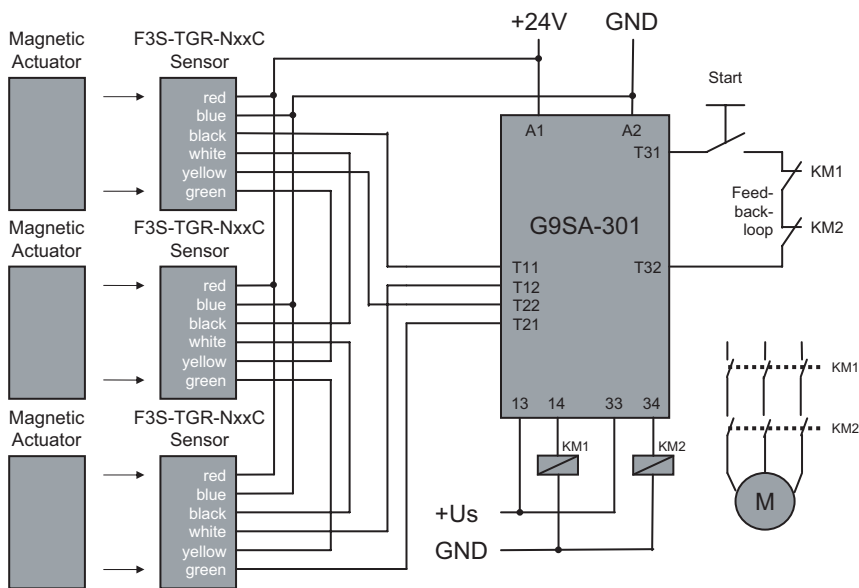

G9SB

**Single Sensor Application with G9SB-2002-C**

(up to Safety Category 4 acc. EN954-1)

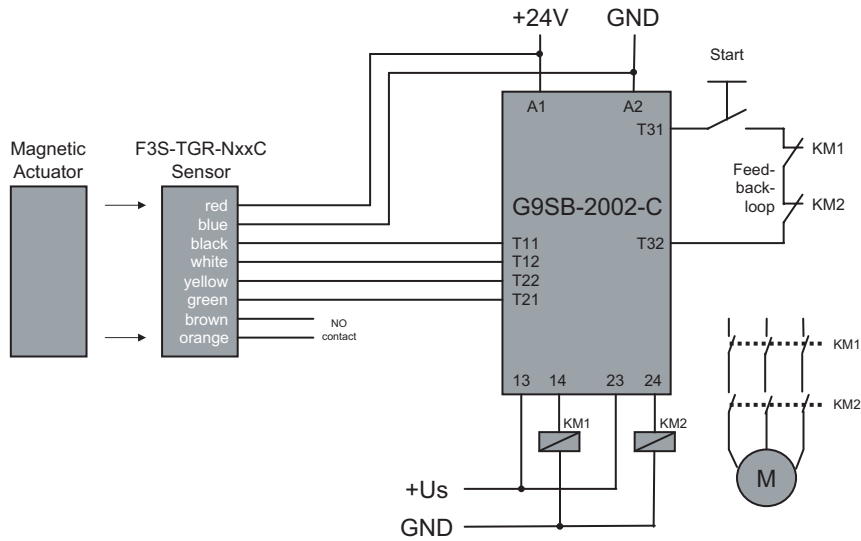

**Series connection Application, up to 6 Sensors with G9SB-2002-C**

(up to safety Category 3 acc. EN954-1)

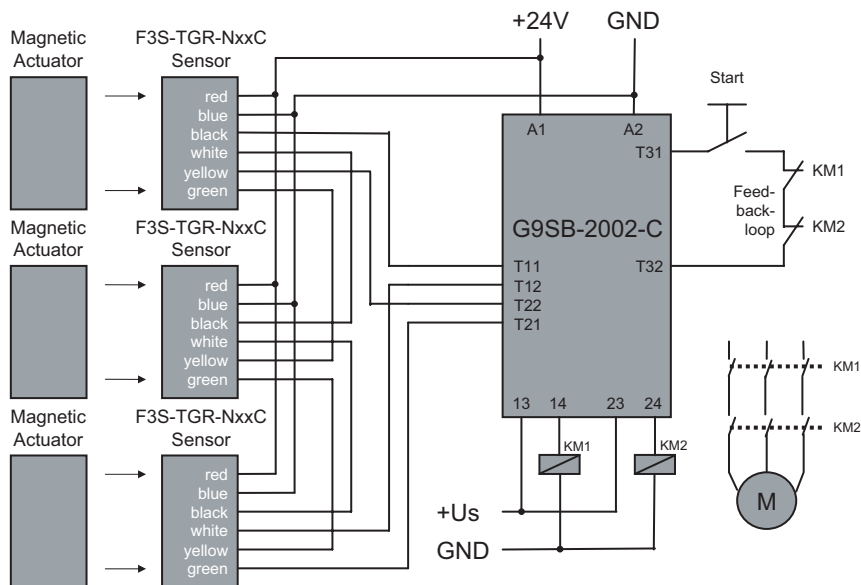



G9SX

Single Sensor Application with G9SX-AD322-T15

(up to Safety Category 4 acc. EN954-1)

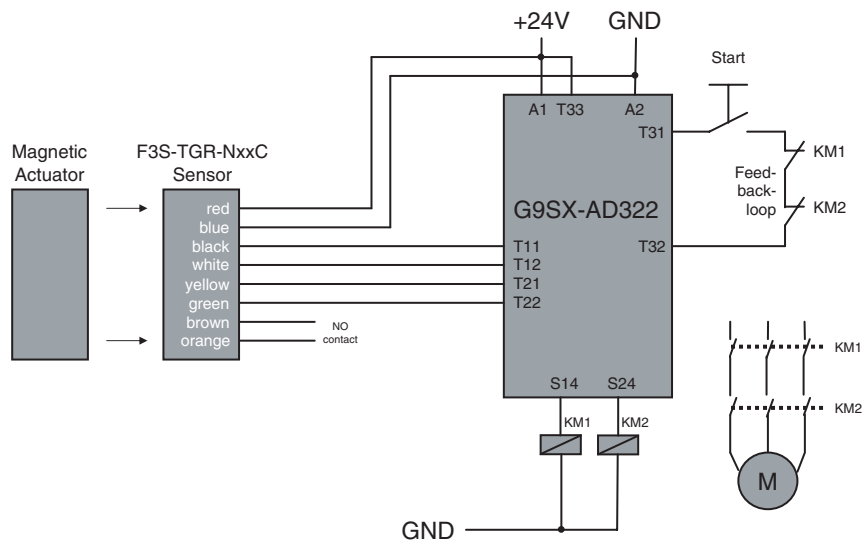

Series connection Application, up to 6 Sensors with G9SX-AD322-T15

(up to Safety Category 3 acc. EN954-1)

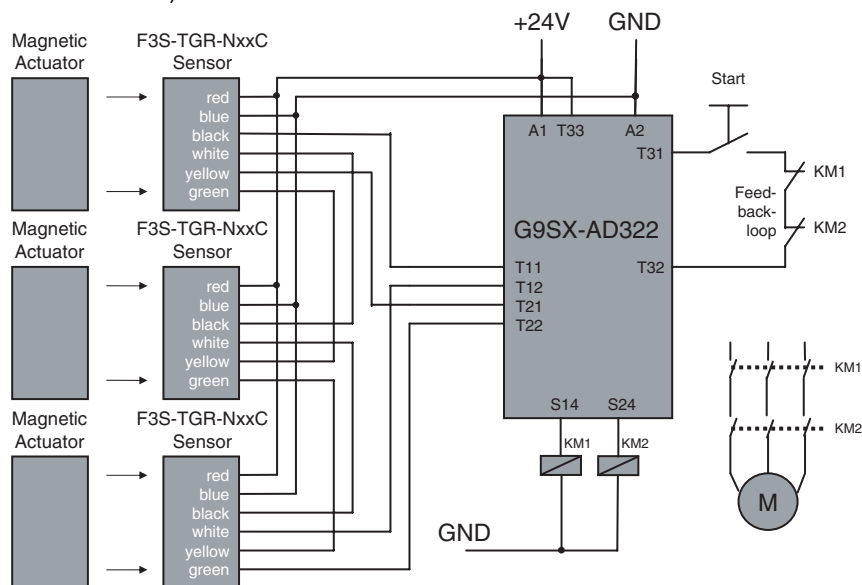

DeviceNet Safety NE1A and DST1-I/O-Terminals

**Single Sensor Application with NE1A and DST1-Safety-IO**

(up to safety Category 4 acc. EN954-1)

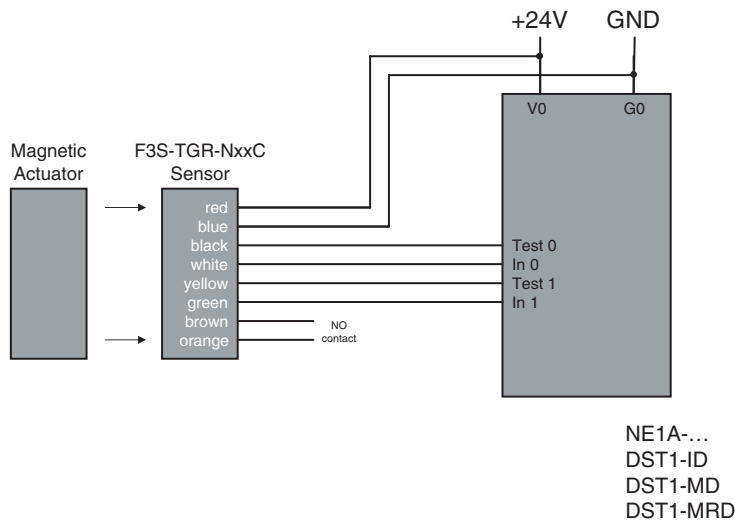

**Series connection Application, up to 6 Sensors with NE1A or DST1-Safety-IO**

(up to Safety Category 3 acc. EN954-1)

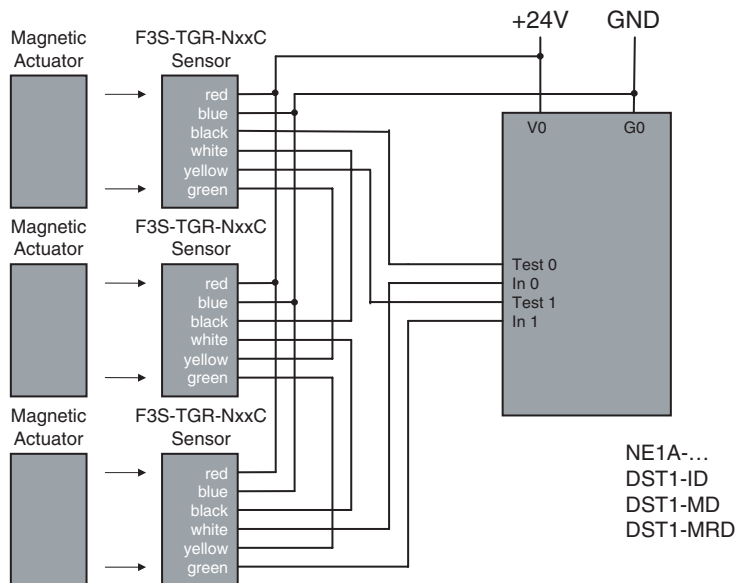

**Application with multiple Sensors with NE1A or DST1-Safety-IO**

(up to Safety Category 4 acc. EN954-1)

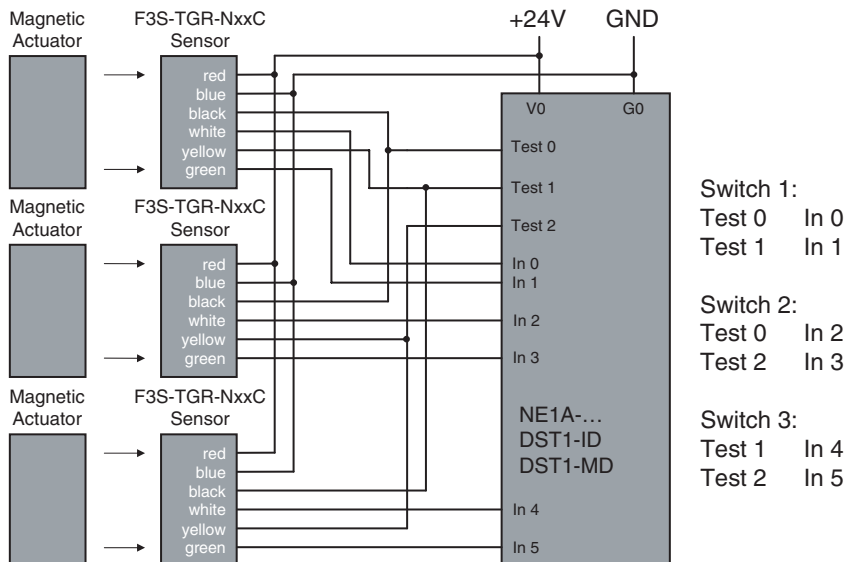

## Safety Precautions

### ⚠ WARNING

Be sure to turn OFF the power before performing wiring. Do not touch charge parts (e.g., terminals) while power is ON. Doing so may result in electric shock.



Do not allow the actuator to come close to the switch with the door open. Doing so may cause machinery to start operating and may result in injury.



Keep actuators (magnets) away from magnetically sensitive equipment like PC harddisks, floppy disks etc. The magnetic field of the magnet will damage existing data.



### ⚠ CAUTION

Use guard stops in the way shown below to ensure that the switch and actuator do not make contact when the guard door is closed.

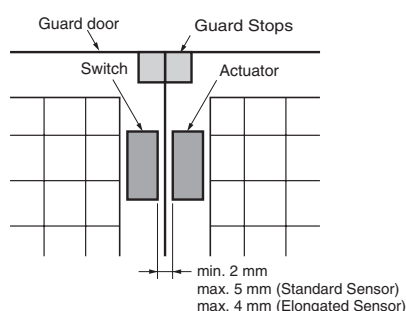

## Application Precautions

- Do not use the product in locations subject to explosive or flammable gases.
- Do not use load currents exceeding the rated value.
- Be sure to wire each conductor correctly.
- Be sure to confirm correct operation after completing mounting and adjustment.
- Do not drop or attempt to disassemble the product.
- Be sure to use the correct combination of switch and actuator.
- Use a power supply of the specified voltage. Do not use power supplies with large ripples or power supplies that intermittently generate incorrect voltages.
- Capacitors are consumable and require regular maintenance and inspection.

## Precautions for Safe Use

### Mounting Direction of Switch and Actuator

The Sensor will not operate properly if the switch and actuator come towards each other diagonally. The Sensor will, however, operate properly if the switch and actuator come towards each other head-on, horizontally or vertically (as long as the faces have the same orientation).

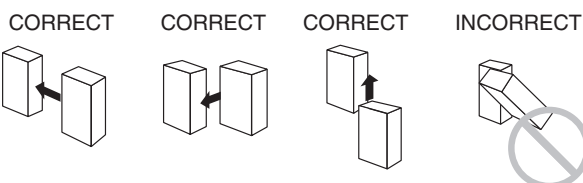
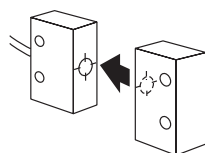

## Mutual Interference

If the switch and actuator are mounted in parallel, be sure to separate them by at least 25 mm, as shown below.

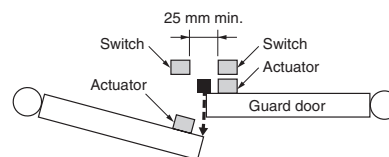

## Using for Hinged Doors

On hinged doors, install the Sensor at an opening edge as shown below.

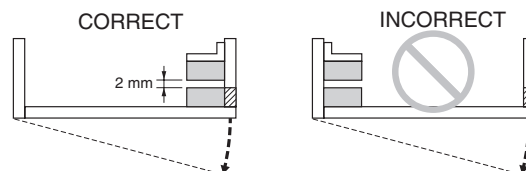

## Solvents

Ensure that solvents, such as alcohol, thinner, trichloroethane, or gasoline do not adhere to the product. Solvents may cause markings to fade and components to deteriorate.

## Installation Location

Do not install the product in the following locations. Doing so may result in product failure or malfunction.

- Locations subject to direct sunlight
- Locations subject to humidity levels outside the range 35% to 85% or subject to condensation due to extreme temperature changes
- Locations subject to corrosive or flammable gases
- Locations subject to shocks or vibration in excess of the product ratings
- Locations subject to dust (including iron dust) or salts

Take appropriate and sufficient countermeasures when using the product in the following locations.

- Locations subject to static electricity or other forms of noise
- Locations subject to possible exposure to radioactivity
- Locations subject to power supply lines
- It is advisable to mount the switches on non ferrous materials. The presence of ferrous material can effect switching sensitivity.

## Wiring

Perform wiring using wire with the following dimensions.

Stranded wire: 2.5 mm<sup>2</sup>

Solid wire: 4.0 mm<sup>2</sup>

Tighten the terminal screws with the specified torque. Not doing so may result in malfunction or abnormal heat generation.

Terminal screw tightening torque: 1 Nm for NLPC and NSMC  
0,8 Nm for NMPC

ALL DIMENSIONS SHOWN ARE IN MILLIMETERS.

To convert millimeters into inches, multiply by 0.03937. To convert grams into ounces, multiply by 0.03527.