



VARISPEED E7

Drive your energy costs down

Model: CIMR-E7Z

200V Class Single-phase 0.4 to 110 kW

400V Class 3-phase 0.4 to 300 kW

QUICK START GUIDE



E7Z Quick Start Guide

Table of Contents

Warnings	EN-1
◆ Safety Precautions and Instructions	EN-2
◆ EMC Compatibility	EN-3
Installation	EN-5
◆ Mechanical Installation	EN-5
◆ Electrical Connection	EN-7
◆ Wiring Main Circuit Inputs	EN-11
Keypad Operation	EN-13
◆ Digital Operator Display (optional)	EN-13
Power Up and Basic Parameter Setup	EN-15
◆ Start Up Procedure	EN-15
◆ Before Power Up	EN-16
◆ Display after Power Up	EN-16
◆ Autotuning for Line-to-Line Resistance	EN-16
User Parameters	EN-16
Troubleshooting	EN-24
◆ General Faults and Alarms	EN-24
◆ Operator Programming Errors	EN-25
◆ Autotuning Faults	EN-26

Warnings



CAUTION

Cables must not be connected or disconnected, nor signal tests carried out, while the power is switched on.

The Varispeed E7 DC bus capacitor remains charged even after the power has been switched off. To avoid an electric shock hazard, disconnect the frequency inverter from the mains before carrying out maintenance. Then wait for at least 5 minutes after all LEDs have gone out.

Do not perform a withstand voltage test on any part of the Varispeed. The frequency inverter contains semiconductors, which are not designed for such high voltages.

Do not remove the digital operator while the mains supply is switched on. The printed circuit board must also not be touched while the inverter is connected to the power.

Never connect general LC/RC interference suppression filters, capacitors or overvoltage protection devices to the inverter input or output.

To avoid unnecessary overcurrent faults, etc. being displayed, the signaling contacts of any contactor or switch fitted between inverter and motor must be integrated into the inverter control logic (e.g. baseblock).

This is absolutely imperative!

This manual must be read thoroughly before connecting and operating the inverter. All safety precautions and instructions for use must be followed.

The inverter may must be operated with the appropriate line filters, following the installation instructions in this manual and with all covers closed and terminals covered.

Only then will adequate protection be provided. Please do not connect or operate any equipment with visible damage or missing parts. The operating company is responsible for any injuries or equipment damage resulting from failure to heed the warnings in this manual.

◆ Safety Precautions and Instructions

■ General

Please read these safety precautions and instructions for use thoroughly before installing and operating this inverter. Also read all of the warning signs on the inverter and ensure they are never damaged or removed.

Live and hot inverter components may be accessible during operation. Removal of housing components, the digital operator or terminal covers runs the risk of serious injuries or damage in the event of incorrect installation or operation. The fact that frequency inverters control rotating mechanical machine components can give rise to other dangers.

The instructions in this manual must be followed. Installation, operation and maintenance may only be carried out by qualified personnel. For the purposes of the safety precautions, qualified personnel are defined as individuals who are familiar with the installation, starting, operation and maintenance of frequency inverters and have the proper qualifications for this work. Safe operation of these units is only possible if they are used properly for their intended purpose.

The DC bus capacitors can remain live for about 5 minutes after the inverter is disconnected from the power. It is therefore necessary to wait for this time before opening its covers. All of the main circuit terminals may still carry dangerous voltages.

Children and other unauthorized persons must not be allowed access to these inverters.

Keep these Safety Precautions and Instructions for Use readily accessible and supply them to all persons with any form of access to the inverters.

■ Intended Use

Frequency inverters are intended for installation in electrical systems or machinery.

Their installation in machinery and systems must conform to the following product standards of the Low Voltage Directive:

EN 50178, 1997-10, Equipping of Power Systems with Electronic Devices

EN 60204-1, 1997-12 Machine Safety and Equipping with Electrical Devices

Part 1: General Requirements (IEC 60204-1:1997)/

Please note: Includes Corrigendum of September 1998

EN 61010-1, A2, 1995 Safety Requirements for Information Technology Equipment

(IEC 950, 1991 + A1, 1992 + A2, 1993 + A3, 1995 + A4, 1996, modified)

CE marking is carried out to EN 50178, using the line filters specified in this manual and following the appropriate installation instructions.

■ Transportation and storage

The instructions for transportation, storage and proper handling must be followed in accordance with the technical data.

■ Installation

Install and cool the inverters as specified in the documentation. The cooling air must flow in the specified direction. The inverter may therefore only be operated in the specified position (e.g. upright). Maintain the specified clearances. Protect the inverters against impermissible loads. Components must not be bent nor insulation clearances changed. To avoid damage being caused by static electricity, do not touch any electronic components or contacts.

■ Electrical Connection

Carry out any work on live equipment in compliance with the national safety and accident prevention regulations. Carry out electrical installation in compliance with the relevant regulations. In particular, follow the installation instructions ensuring electromagnetic compatibility (EMC), e.g. shielding, grounding, filter arrangement and laying of cables. This also applies to equipment with the CE mark. It is the responsibility of the manufacturer of the system or machine to ensure conformity with EMC limits.

Your supplier or Omron Yaskawa Motion Control representative must be contacted when using leakage current circuit breaker in conjunction with frequency inverters.

In certain systems it may be necessary to use additional monitoring and safety devices in compliance with the relevant safety and accident prevention regulations. The frequency inverter hardware must not be modified.

■ Notes

The Varispeed E7 frequency inverters are certified to CE, UL, and cUL

◆ EMC Compatibility

■ Introduction

This manual was compiled to help system manufacturers using OMRON YASKAWA Motion Control (OYMC) frequency inverters design and install electrical switch gear. It also describes the measures necessary to comply with the EMC Directive. The manual's installation and wiring instructions must therefore be followed.

Our products are tested by authorized bodies using the standards listed below.

Product standard: EN 61800-3:1996
EN 61800-3; A11:2000

■ Measures to Ensure Conformity of OYMC Frequency inverters to the EMC Directive

OYMC frequency inverters do not necessarily have to be installed in a switch cabinet.

It is not possible to give detailed instructions for all of the possible types of installation. This manual therefore has to be limited to general guidelines.

All electrical equipment produces radio and line-borne interference at various frequencies. The cables pass this on to the environment like an aerial.

Connecting an item of electrical equipment (e.g. drive) to a supply without a line filter can therefore allow HF or LF interference to get into the mains.

The basic countermeasures are isolation of the wiring of control and power components, proper grounding and shielding of cables.

A large contact area is necessary for low-impedance grounding of HF interference. The use of grounding straps instead of cables is therefore definitely advisable.

Moreover, cable shields must be connected with purpose-made ground clips.

■ Laying Cables

Measures Against Line-Borne Interference:

Line filter and frequency inverter must be mounted on the same metal plate. Mount the two components as close to each other as possible, with cables kept as short as possible.

Use a power cable with well-grounded shield. For motor cables up to 50 meters in length use shielded cables. Arrange all grounds so as to maximize the area of the end of the lead in contact with the ground terminal (e.g. metal plate).

Shielded Cable:

- Use a cable with braided shield.
- Ground the maximum possible area of the shield. It is advisable to ground the shield by connecting the cable to the ground plate with metal clips (see following figure).

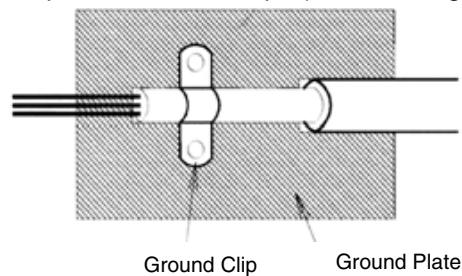

Fig 1 Earthing the cable shield with metal clips

The grounding surfaces must be highly conductive bare metal. Remove any coats of varnish and paint.

- Ground the cable shields at both ends.
- Ground the motor of the machine.

Installation

◆ Mechanical Installation

■ Unpacking the Inverter

Check the following items after unpacking the inverter.

Item	Method
Has the correct Inverter model been delivered?	Check the model number on the nameplate on the side of the Inverter.
Is the Inverter damaged in any way?	Inspect the entire exterior of the Inverter to see if there are any scratches or other damage resulting from shipping.
Are any screws or other components loose?	Use a screwdriver or other tools to check for tightness.

If any irregularities in the above items are found, contact the agency from which the Inverter was purchased or your Omron Yaskawa Motion Control representative immediately..

■ Checking the Installation Site

Protection covers are attached to the top and bottom of the NEMA 1 and IP00 Inverters. Be sure to remove the top cover before operating a 200 or 400 V Class Inverter with a capacity of 18.5 kW or less inside a panel.

Observe the following precautions when mounting the Inverter:

- Install the Inverter in a clean location which is free from oil mist and dust. It can be installed in a totally enclosed panel that is completely shielded from floating dust.
- When installing or operating the Inverter, always take special care so that metal powder, oil, water, or other foreign matter does enter the Inverter.
- Do not install the Inverter on combustible material, such as wood.
- Install the Inverter in a location free from radioactive materials and combustible materials.
- Install the Inverter in a location free from harmful gasses and liquids.
- Install the Inverter in a location without excessive oscillation.
- Install the Inverter in a location free from chlorides.
- Install the Inverter in a location without direct sunlight.

■ Installation Orientation

Install the Inverter vertically so as not to reduce the cooling effect. When installing the Inverter, always provide the following installation space to allow normal heat dissipation.

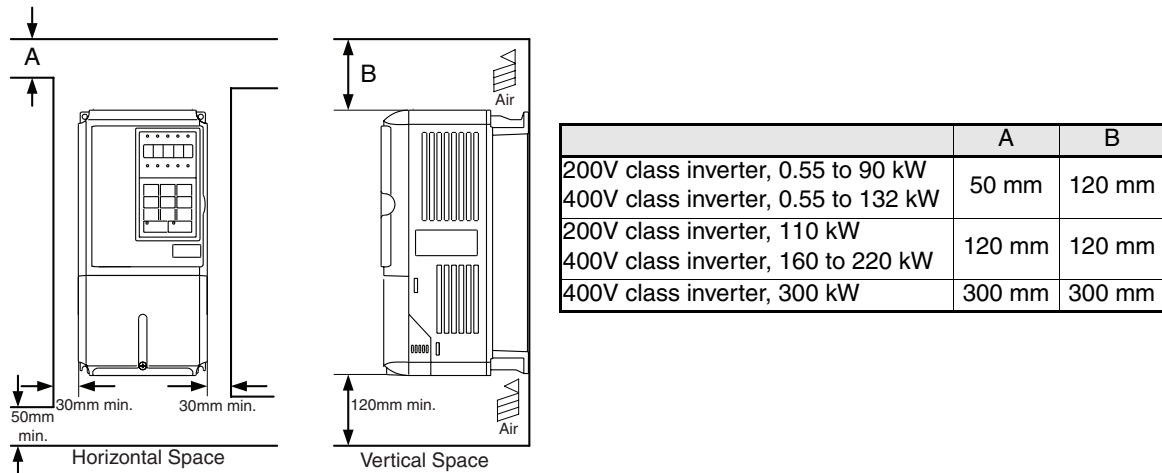

Fig 2 Installation space



1. The same space is required horizontally and vertically for IP00, IP20 and NEMA 1 Inverters.
2. Always remove the top protection cover after installing an Inverter with an output of 18.5 kW or less in a panel.
Always provide enough space for suspension eye bolts and the main circuit lines when installing an Inverter with an output of 22 kW or more in a panel.

■ Installation of Inverters and EMC filters

For an EMC rules compliant installation consider the following points:

- Use a line filter.
- Use shielded motor cables.
- Mount the inverter and filter on a grounded conductive plate.
- Remove any paint or dirt before mounting the parts in order to reach the lowest possible grounding impedance.

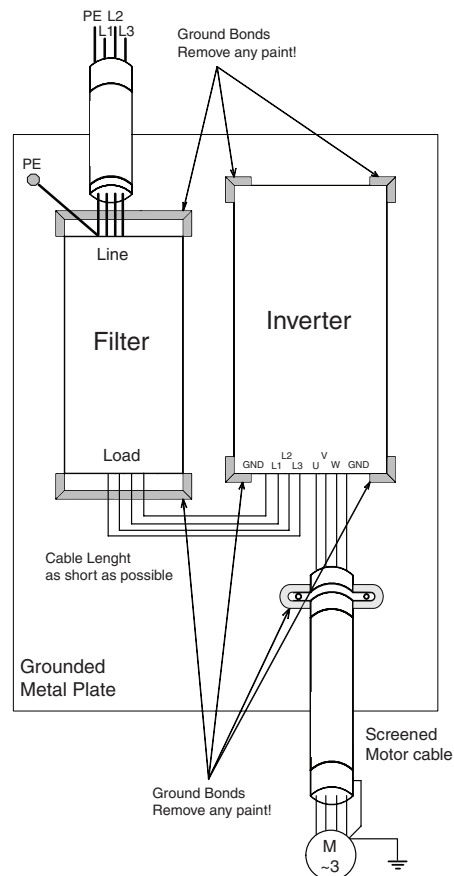

Fig 3 EMC filter installation

◆ Electrical Connection

■ Wiring the Inverter

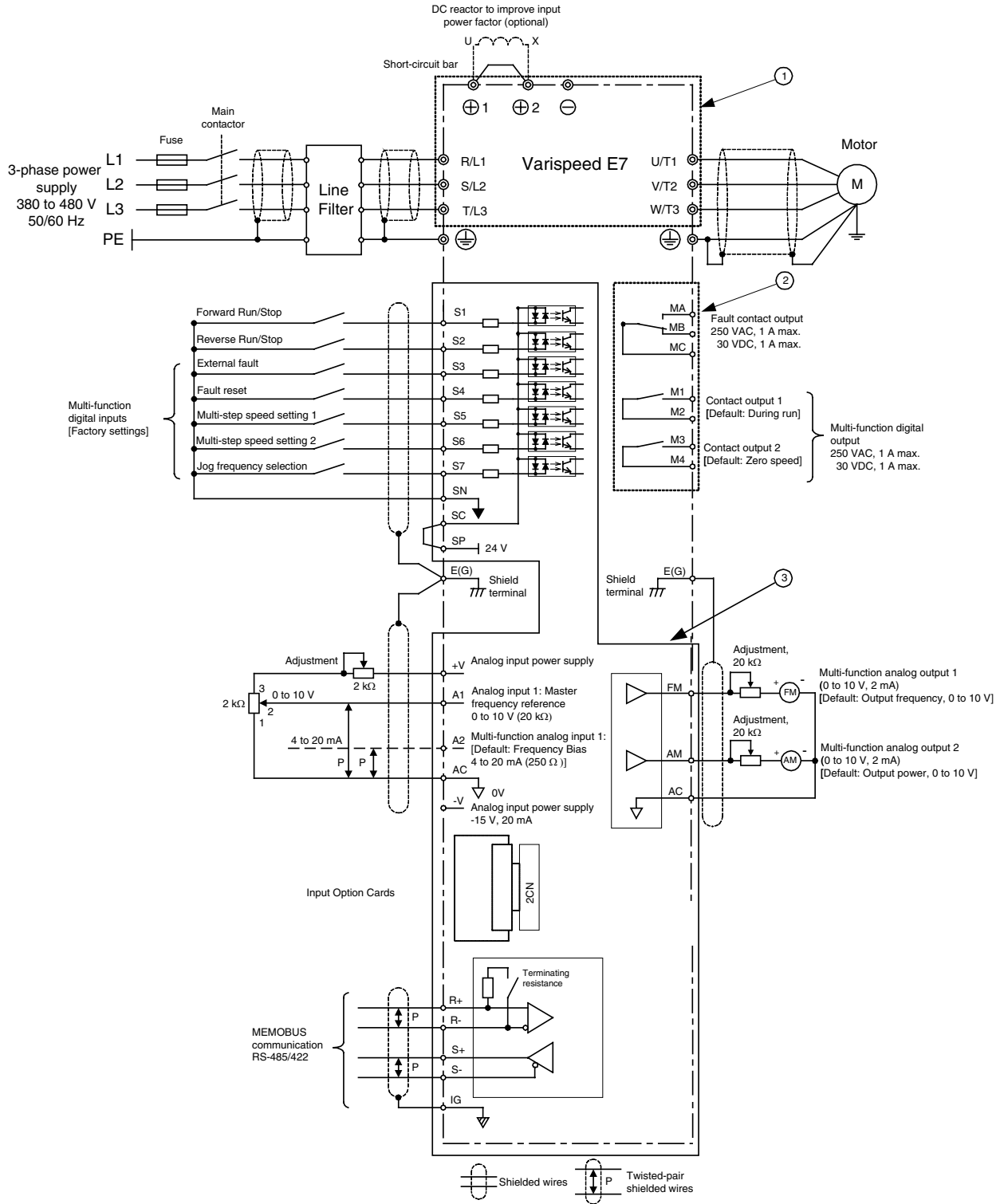

Fig 4 Wiring Diagram

■ Main Circuit Terminals

Main circuit terminal functions are summarized according to terminal symbols in [Table 1](#). Wire the terminals correctly for the desired purposes.

Table 1 Main Circuit Terminal Functions (200 V Class and 400 V Class)

Purpose	Terminal Symbol	Model: CIMR-E7Z□□□□	
		200 V Class	400 V Class
Main circuit power input	R/L1, S/L2, T/L3	20P4 to 2110	40P4 to 4300
	R1/L11, S1/L21, T1/L31	2022 to 2110	4022 to 4300
Inverter outputs	U/T1, V/T2, W/T3	20P4 to 2110	40P4 to 4300
DC bus terminals	⊕1, ⊖	20P4 to 2110	40P4 to 4300
DC reactor connection	⊕1, ⊕2	20P4 to 2018	40P4 to 4018
Braking Unit connection	⊕3, ⊖	2022 to 2110	4022 to 4300
Ground	⊕	20P4 to 2110	40P4 to 4300

■ Control Circuit Terminals

[Fig 5](#) shows the control terminal arrangement. The functions of the control circuit terminals are shown in [Table 2](#). Use the appropriate terminals for the correct purposes.

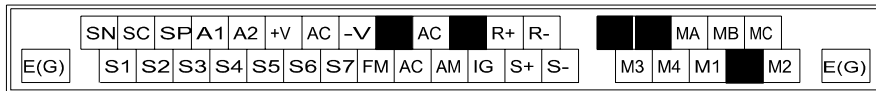

Fig 5 Control terminal arrangement

Table 2 Control Circuit Terminals with default settings

Type	No.	Signal Name	Function		Signal Level
Digital input signals	S1	Forward run/stop command	Forward run when ON; stopped when OFF.		24 VDC, 8 mA Photocoupler isolation
	S2	Reverse run/stop command	Reverse run when ON; stopped when OFF.		
	S3	External fault input ^{*1}	Fault when ON.	Functions are selected by setting H1-01 to H1-05.	
	S4	Fault reset ^{*1}	Reset when ON		
	S5	Multi-step speed reference 1 ^{*1} (Master/auxiliary switch)	Auxiliary frequency reference when ON.		
	S6	Multi-step speed reference 2 ^{*1}	Multi-step speed 2 when ON.		
	S7	Jog frequency reference ^{*1}	Jog frequency when ON.		
	SC	Digital input common	-		-
	SN	Digital Input Neutral	-		-
SP	Digital Input Power Supply	+24VDC power supply for digital inputs		24 VDC, 250 mA max. ^{*2}	
Analog input signals	+V	15 V power output	15 V power supply for analog references		15 V (Max. curr.: 20mA)
	A1	Frequency reference	0 to +10 V/100%		0 to +10 V (20 kΩ)
	A2	Auxiliary Frequency Reference	Auxiliary analog frequency reference; 4 to 20 mA (250Ω)	Function is selected by setting H3-09.	4 to 20 mA (250Ω) 0 V to +10 V (20kΩ) 0 to 20 mA (250Ω)
	-V	-15 V power output	-15 V power supply for analog references		
	AC	Analog reference common	-		-
E(G)	Shield wire, optional ground line connection point	-		-	

Type	No.	Signal Name	Function	Signal Level
Digital output signals	M1	During run (1NO contact)	Closed during Run	Relay contacts Contact capacity: 1 A max. at 250 VAC 1 A max. at 30 VDC ^{*3}
	M2			
	M3	Zero speed (1NO contact)	CLOSED when output frequency at zero level (b2-01) or below	
	M4			
	MA	Fault output signal	CLOSED across MA and MC during faults OPEN across MB and MC during faults	
	MB			
	MC			
analog output signals	FM	Output frequency	Analog output fre- quency signal; 0 to 10 V; 10V=FMAX	Function selected by H4-01
	AC	Analog common	—	
	AM	Inverter output power	Analog output power signal; 0 to 10V; 10V=max. appl. motor capacity	Function selected by H4-04
RS-485/ 422	R+	MEMOBUS communications input	For 2-wire RS-485, short R+ and S+ as well as R- and S-.	Differential input, PHC isolation
	R-			
	S+	MEMOBUS communications output		Differential input, PHC isolation
	S-			
	IG	Signal common		—

*1. The default settings are given for terminals S3 to S7. For a 3-wire sequence, the default settings are a 3-wire sequence for S5, multi-step speed setting

1 for S6 and multi-step speed setting 2 for S7.

*2. Do not use this power supply for supplying any external equipment.

*3. When driving a reactive load, such as a relay coil with DC power supply, always insert a flywheel diode as shown in [Fig 6](#)

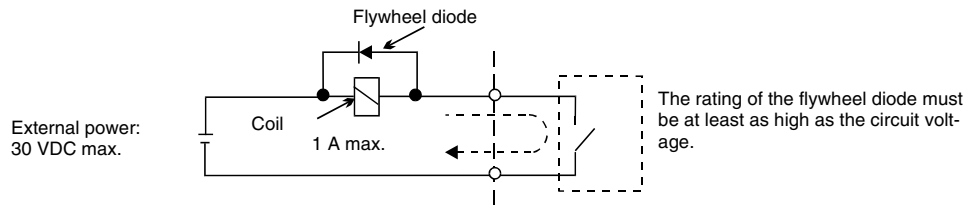

Fig 6 Flywheel Diode Connection



- In [Fig 4](#) the wiring of the digital inputs S1 to S7 is shown for the connection of contacts or NPN transistors (0V common and sinking mode). This is the default setting. For the connection of PNP transistors or for using a 24V external power supply, refer to [Table 3](#).
- A DC reactor is an option only for Inverters of 18.5 kW or less. Remove the short circuit bar when connecting a DC reactor.

■ Sinking/Sourcing Mode (NPN/PNP Selection)

The input terminal logic can be switched over between sinking mode (0-V common, NPN) and sourcing mode (+24V common, PNP) by using the jumper CN5. An external power supply is also supported, providing more freedom in signal input methods.

Table 3 Sinking / Sourcing Mode and Input Signals

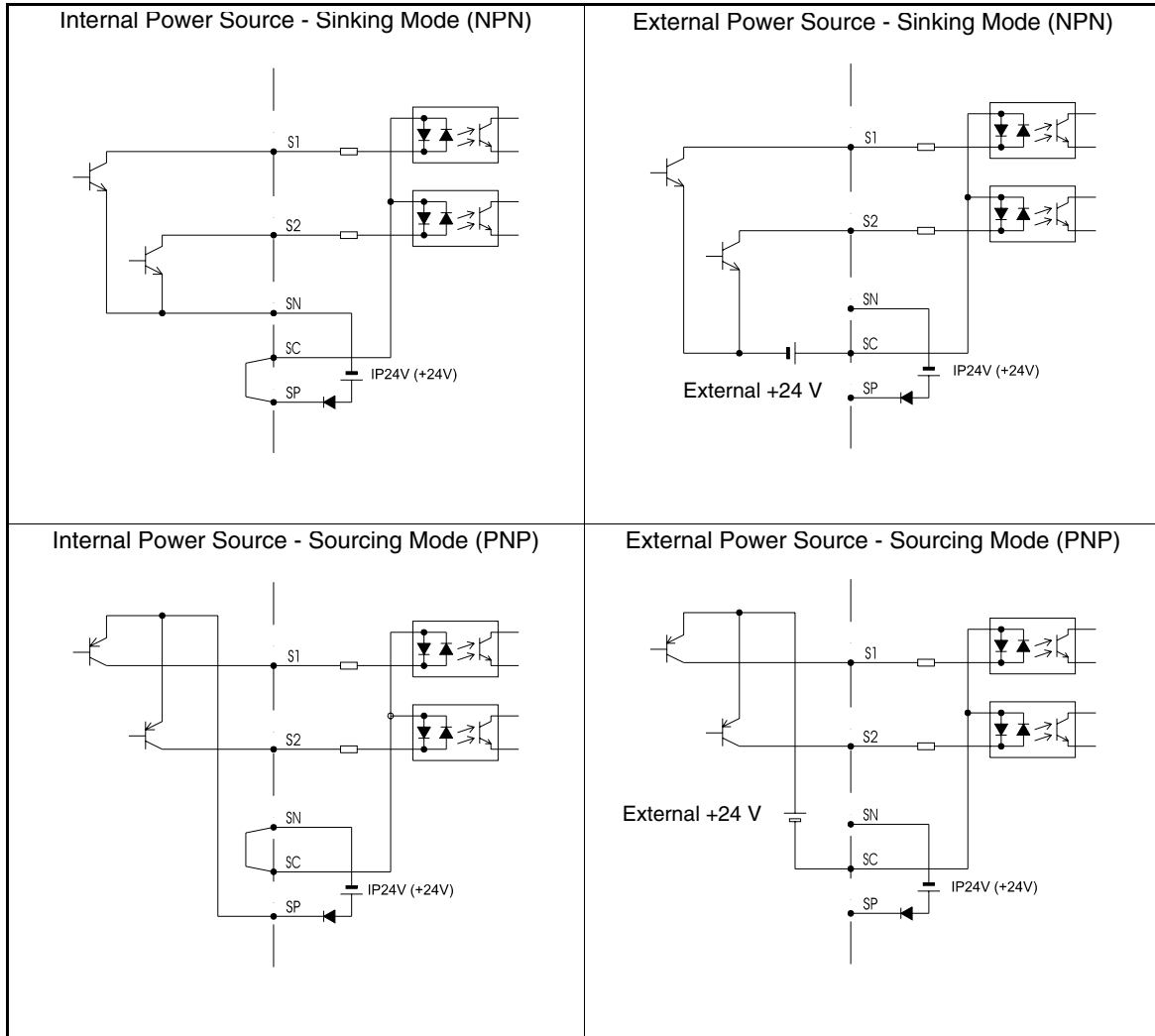

◆ Wiring Main Circuit Inputs

Installing Fuses

To protect the inverter, it is recommended to use semiconductor fuses like they are shown in the table below.

Table 4 Input Fuse Selection

Inverter Type	Rated Inverter Output Current (A)	Fuse Selection			Selection Example (Ferraz)		
		Voltage (V)	Current (A)	I^2t (A ² s)	Model	Rating	I^2t (A ² s)
20P4	3.2	240	10	12~25	A60Q12-2	600V / 12A	17
20P7	4.1	240	10	12~25	A60Q12-2	600V / 12A	17
21P5	7.0	240	15	23~55	A60Q15-2	600V / 15A	26
22P2	9.6	240	20	34~98	A60Q20-2	600V / 20A	41
23P7	15	240	30	82~220	A60Q30-2	600V / 30A	132
25P5	23	240	40	220~610	A50P50-4	500V / 50A	250
27P5	31	240	60	290~1300	A50P80-4	500V / 80A	640
2011	45	240	80	450~5000	A50P80-4	500V / 80A	640
2015	58	240	100	1200~7200	A50P125-4	500V / 125A	1600
2018	71	240	130	1800~7200	A50P150-4	500V / 150A	2200
2022	85	240	150	870~16200	A50P150-4	500V / 150A	2200
2030	115	240	180	1500~23000	A50P200-4	500V / 200A	4000
2037	145	240	240	2100~19000	A50P250-4	500V / 250A	6200
2045	180	240	300	2700~55000	A50P300-4	500V / 300A	9000
2055	215	240	350	4000~55000	A50P350-4	500V / 350A	12000
2075	283	240	450	7100~64000	A50P450-4	500V / 450A	20000
2090	346	240	550	11000~64000	A50P600-4	500V / 600A	36000
2110	415	240	600	13000~83000	A50P600-4	500V / 600A	36000
40P4	1.8	480	5	6~55	A60Q10-2	600V / 10A	10
40P7	2.1	480	5	6~55	A60Q10-2	600V / 10A	10
41P5	3.7	480	10	10~55	A60Q12-2	600V / 12A	17
42P2	5.3	480	10	18~55	A60Q15-2	600V / 15A	26
43P7	7.6	480	15	34~72	A60Q20-2	600V / 20A	41
44P0	8.7	480	20	50~570	A60Q30-2	600V / 30A	132
45P5	12.5	480	25	100~570	A60Q30-2	600V / 30A	132
47P5	17	480	30	100~640	A60Q30-2	600V / 30A	132
4011	24	480	50	150~1300	A70P50-4	700V / 50A	300
4015	31	480	60	400~1800	A70P70-4	700V / 70A	590
4018	39	480	70	700~4100	A70P80-4	700V / 80A	770
4022	45	480	80	240~5800	A70P80-4	700V / 80A	770
4030	60	480	100	500~5800	A70P100-4	700V / 100A	1200
4037	75	480	125	750~5800	A70P125-4	700V / 125A	1900
4045	91	480	150	920~13000	A70P150-4	700V / 150A	2700
4055	112	480	150	1500~13000	A70P200-4	700V / 200A	4800
4075	150	480	250	3000~55000	A70P250-4	700V / 250A	7500
4090	180	480	300	3800~55000	A70P300-4	700V / 300A	11000
4110	216	480	350	5400~23000	A70P350-4	700V / 350A	15000
4132	260	480	400	7900~64000	A70P400-4	700V / 400A	19000
4160	304	480	450	14000~25000 0	A70P450-4	700V / 450A	24000
4185	370	480	600	20000~25000 0	A70P600-4	700V / 600A	43000
4220	506	480	700	34000~40000 0	A70P700-4	700V / 700A	59000
4300	675	480	900	52000~92000 0	A70P900-4	700V / 900A	97000

Consider the following precautions for the main circuit power supply input.

- If a moulded case circuit breaker is used for the power supply connection (R/L1, S/L2, and T/L3), ensure that the circuit breaker is suitable for the Inverter.

- If an earth leakage breaker is used, it should be able to detect all kinds of current should be used in order to ensure a safe earth leakage current detection
- A magnetic contactor or other switching device can be used at the inverter input. The inverter should not be powered up more than once per hour.
- The input phases (R/S/T) can be connected in any sequence.
- If the Inverter is connected to a large-capacity power transformer (600 kW or more) or a phase advancing capacitor is switched nearby, an excessive peak current could flow through the input power circuit, causing an inverter damage. As a countermeasure install an optional AC Reactor at the inverter input or a DC reactor at the DC reactor connection terminals.
- Use a surge absorber or diode for inductive loads near the Inverter. Inductive loads include magnetic contactors, electromagnetic relays, solenoid valves, solenoids, and magnetic brakes.

■Wiring the Output Side of the Main Circuit

The following precautions should be considered for the output circuit wiring.

- Never connect any power source to the inverter output terminals. Otherwise the inverter can be damaged.
- Never short or ground the output terminals. Otherwise the inverter can be damaged.
- Do not use phase correction capacitors. Otherwise the inverter and capacitors can be damaged.
- Check the control sequence to make sure, that the magnetic contactor (MC) between the Inverter and motor is not turned ON or OFF during inverter operation. If the MC is turned ON during the Inverter is operation, a large inrush current will be created and the inverter's overcurrent protection may operate.

■Ground Connection

The following precautions should be considered for the ground connection.

- Do not share the ground wire with other devices, such as welding machines or power tools.
- Always use a ground wire, that complies with technical standards on electrical equipment and minimize the length of the ground wire.

Leakage current is caused by the Inverter. Therefore, if the distance between the ground electrode and the ground terminal is too long, potential on the ground terminal of the Inverter will become unstable.

- When more than one Inverter is used, do not to loop the ground wire.

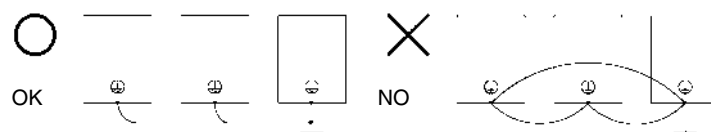

Fig 7 Ground Wiring

■Control Circuit Wiring Precautions

Consider the following precautions for wiring the control circuits.

- Separate control circuit wiring from main circuit wiring (terminals R/L1, S/L2, T/L3, B1, B2, U/T1, V/T2, W/T3, ⊖, ⊕1, ⊕2, and ⊕3, PO, NO) and other high-power lines.
- Separate wiring for control circuit terminals MA, MB, MC, M1, M2, M3 and M4 (relay outputs) from wiring to other control circuit terminals.
- If an optional external power supply is used, it should be a UL Listed Class 2 power supply.
- Use twisted-pair or shielded twisted-pair cables for control circuits to prevent operating faults.
- Ground the cable shields with the maximum contact area of the shield and ground.
- Cable shields have to be grounded on both cable ends.

Keypad Operation











◆ Digital Operator Display (optional)

The key names and functions of the Digital Operator are described below



- Drive Mode Indicators
 - FWD: Lights up when a forward run command is input.
 - REV: Lights up when a reverse run command is input.
 - SEQ: Lights up when the run command from the control circuit terminal is enabled.
 - REF: Lights up when the frequency reference from control circuit terminals A1 and A2 is enabled.
 - ALARM: Lights up when an error or alarm has occurred.
- Data Display
 - Displays monitor data, parameter numbers, and settings.
- Mode Display
 - DRIVE: Lights up in Drive Mode.
 - QUICK: Lights up in Quick Programming Mode.
 - ADV: Lights up in Advanced Programming Mode.
 - VERIFY: Lights up in Verify Mode.
 - A. TUNE: Lights up in Autotuning Mode.
- Keys
 - Execute operations such as setting user parameters, monitoring, jogging, and autotuning.

■ Digital Operator Keys

Key	Name	Function
	LOCAL/REMOTE Key	Switches between operation via the Digital Operator (LOCAL) and the settings in b1-01 and b1-02 (REMOTE). This key can be enabled or disabled by setting parameter o2-01.
	MENU Key	Selects the modes.
	ESC Key	Returns to the status before the DATA/ENTER Key was pressed.
	JOG Key	Enables jog operation when the Inverter is being operated from the Digital Operator.
	FWD/REV Key	Selects the rotation direction of the motor when the Inverter is being operated from the Digital Operator.
	Shift/RESET Key	Sets the active digit when programming user parameters. Also acts as the Reset key when a fault has occurred.
	Increment Key	Selects user parameter numbers and increments parameter settings. Used to move to the next item or data.
	Decrement Key	Selects user parameter numbers and decrements parameter settings. Used to move to the previous item or data.
	DATA/ENTER Key	Enters menus and parameters and validates parameter settings.
	RUN Key	Starts operation when the Inverter is being controlled by the Digital Operator (LOCAL Mode).
	STOP Key	Stops Inverter operation (LOCAL and REMOTE Mode). This key can be enabled or disabled when operating from a source

Power Up and Basic Parameter Setup

◆ Start Up Procedure

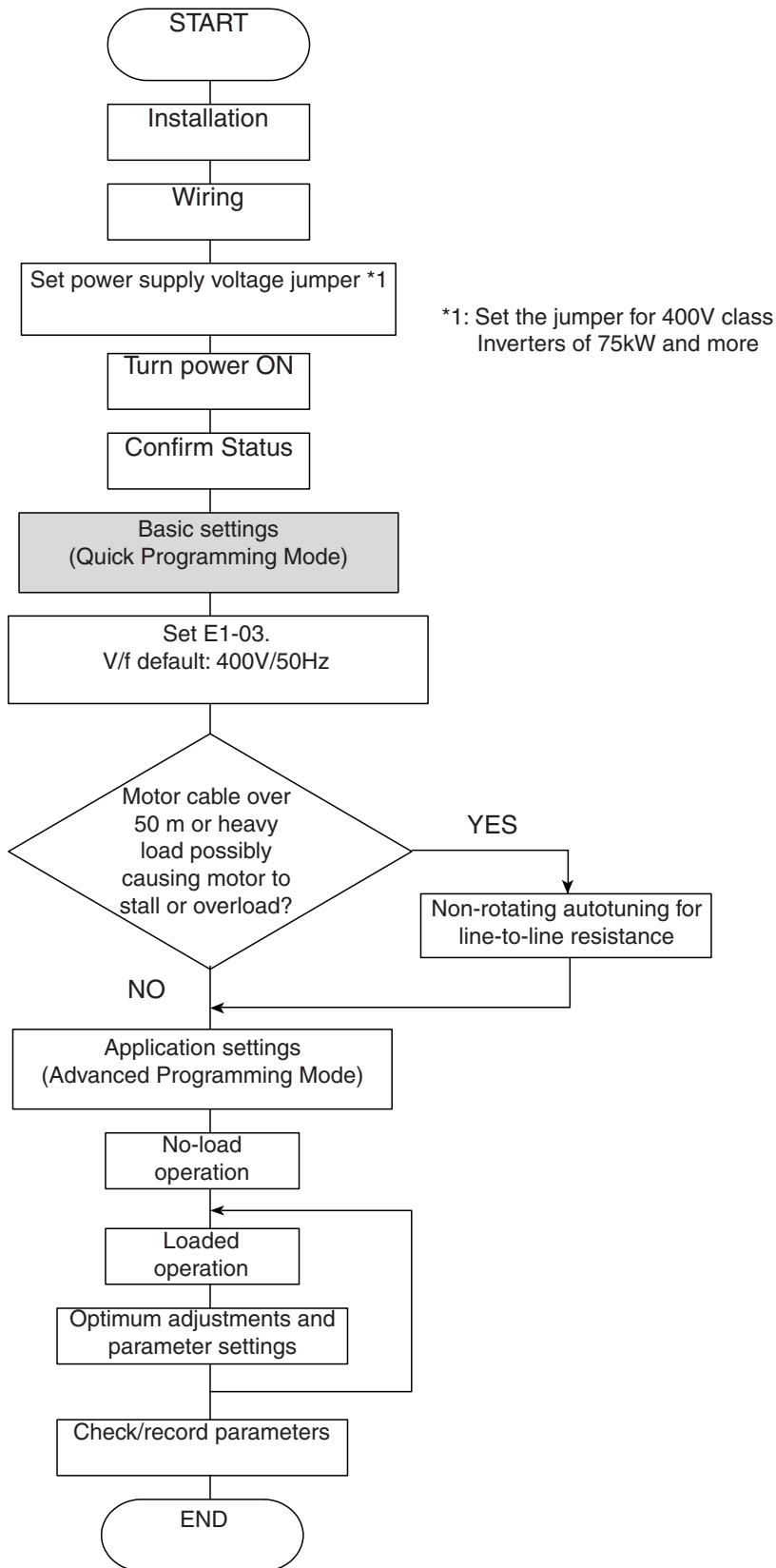

Fig 8 Trial Operation Flowchart

◆ Before Power Up

The following points should be checked carefully before the power is switched on.

- Check if the power supply meets the inverter specification.
- Check if the power supply cables are tightly connected to the right terminals (L1, L2, L3).
- Check if the motor cables are tightly connected to the right terminals on the inverter side (U, V, W) as well as on the motor side.
- Check if the braking unit / braking resistor is connected correctly.
- Check if the Inverter control circuit terminal and the control device are wired correctly.
- Set all Inverter control circuit terminals to OFF.
- When a PG card is used, check if it is wired correctly.

◆ Display after Power Up

After normal power up without any problems the operator display shows the following messages

Display for normal operation



The frequency reference monitor is displayed in the data display section.

When a fault has occurred or an alarm is active a fault or alarm message will appear. In this case, refer to [page 21, Troubleshooting](#).

Display for fault operation

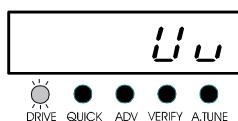

A fault or alarm message is shown on the display.
The example shows a low voltage alarm.

◆ Autotuning for Line-to-Line Resistance

Autotuning can be used to improve the performance when very long motor cables are used or when motor and inverter have different power ratings.

To perform autotuning set T1-02 (Motor rated power) and T1-04 (Motor rated current) and then press the RUN key on the Digital Operator. The Inverter will supply power to the motor for approximately 20 seconds and the line-to-line resistance (stator windings and cable resistance) will be measured automatically.



IMPORTANT

1. Power will be supplied to the motor during autotuning but the motor will not turn. Do not touch the motor until autotuning has been completed.
2. Ensure that all motor contactors are closed before the autotuning is started.
3. To cancel autotuning press the STOP key on the Digital Operator.

■ Other Alarms and Faults During Autotuning

For an overview of possible autotuning alarms or faults and corrective actions refer to [page 23, Auto-tuning Faults](#).

User Parameters

Parameter Number	Name	Description
Initialize Data		
A1-00	Language selection for Digital Operator display(JVOP-160-OY only)	0:English 2:German 3:French 4:Italian 5:Spanish 6:Portuguese
A1-01	Parameter access level	0:Monitoring only (Monitoring drive mode and setting A1-01 and A1-04.) 1:Used to select user parameters (Only parameters set in A2-01 to A2-32 can be read and set.) 2:Advanced (Parameters can be read and set in both, quick programming mode (Q) and advanced programming mode (A).)
A1-03	Initialize	0: No initializing 1110:Initializes using the user parameters 2220:Initializes using a two-wire sequence. (Initializes to the factory setting.) 3330:Initializes using a three-wire sequence.
Sequence / Reference Source		
b1-01	Reference source selection	Sets the frequency reference input method. 0:Digital Operator 1:Control circuit terminal (analog input) 2:Serial communication (RS422 / 485) 3:Option Card
b1-02	RUN command source selection	Sets the run command input method. 0:Digital Operator 1:Control circuit terminal (digital inputs) 2:Serial communication (RS422 / 485) 3:Option Card
b1-03	Stopping method selection	Selects the stopping method when the Run signal is removed 0:Deceleration to stop 1:Coast to stop 2:DC injection to stop 3:Coast to stop with timer (New Run commands are disregarded while coasting.)
b1-04	Prohibition of reverse operation	0:Reverse enabled 1:Reverse disabled 2:Output Phase Rotation (both rotational directions are enabled) 3:Output Phase Rotation with Reverse disabled.
Speed Search		
b3-01	Speed search selection (current detection or speed calculation)	Enables/disables the speed search function and sets the speed search method. 0:Disabled, speed calculation 1:Enabled, speed calculation 2:Disabled, current detection 3:Enabled, current detection

Parameter Number	Name	Description
b3-14	Bi-directional speed search selection	Disables or enables the bi-directional capabilities of the speed search function. 0:Disabled 1:Enabled
PI Control		
b5-01	PI control mode selection	0:Disabled 1:Enabled 3:PI control enabled (frequency reference + PI output)
b5-02	Proportional (P) gain	Sets the proportional gain of the PI controller. P control is not performed when set 0.00.
b5-03	Integral (I) time	Sets the integral time of the PI controller. I control is not performed when set to 0.0 sec.
b5-09	PI output characteristics selection	Selects forward/reverse direction for PI output. 0:PI output is forward 1:PI output is reverse.
b5-17	Accel/decel time for PI reference	Sets the accel/decel time for the PI Softstarter (SFS).
b5-18	PI Setpoint Selection	0:Disabled 1:Enabled
b5-19	PI Setpoint	PI target value
Acceleration / Deceleration Settings		
C1- <input type="checkbox"/>	Acceleration/Deceleration times	Sets the time to accelerate/decelerate from 0 Hz to the maximum output frequency.
S-Curve Settings		
C2- <input type="checkbox"/>	S-curve characteristic time at acceleration	Sets the S-curve characteristic at acceleration start and end.
Carrier Frequency		
C6-02	Carrier frequency selection	Selects the carrier frequency (factory setting depends on Inverter capacity) 0: Low noise, low carrier 1: 2.0 kHz 2: 5.0 kHz 3: 8.0 kHz 4: 10.0 kHz 5: 12.5 kHz 6: 15.0 kHz F: Programmable pattern
Speed Settings		
d1-01 to d1-04	Multi speed references 1 to 4	Sets the multi-step speed references.
d1-17	Jog frequency reference	
Reference Limits		
d2-01	Frequency reference upper limit	Sets the frequency reference upper limit in percent of the max. output frequency (E1-04)
d2-02	Frequency reference lower limit	Sets the frequency reference lower limit in percent of the max. output frequency (E1-04)

Parameter Number	Name	Description
V/f Pattern Settings		
E1-01	Input voltage setting	This setting is used as a reference value for protection functions.
E1-04	Max. output frequency (FMAX)	<p>Output Voltage (V)</p> <p>VMAX (E1-05) (VBASE) (E1-13)</p> <p>VB (E1-08)</p> <p>VMIN (E1-10)</p> <p>FMIN (E1-09) FB (E1-07) FA (E1-06) FMAX (E1-04)</p> <p>Frequency (Hz)</p>
E1-05	Max. output voltage (VMAX)	
E1-06	Base frequency (FA)	
E1-13	Base Voltage (VBASE)	To set V/f characteristics in a straight line, set the same values for E1-07 and E1-09. In this case, the setting for E1-08 will be disregarded. Always ensure that the four frequencies are set in the following order: E1-04 (FMAX) ≥ E1-06 (FA) > E1-07 (FB) ≥ E1-09 (FMIN)
Motor Data Settings		
E2-01	Motor rated current	Sets the motor data. Set the correct values if the thermal motor protection is used.
E2-03	Motor no-load current	
E2-05	Motor line-to-line resistance	
Digital I/O Settings		
H1-01 to H1-05	Terminal S3 to S7 function selection	Refer to page 20, Digital Input Function Selections (H1-01 to H1-05) for a list of selections
H2-01 and H2-02	Terminal M1-M2 and M3-M4 function selection	Refer to page 20, Digital Output Function Selections for a list of selections
Analog I/O Settings		
H3-08	Analog input A2 signal level selection	Selects the signal level input at multi-function analog input A2. 0:0 to +10V (11 bit). 2:4 to 20 mA (9-bit input). 3:0 to 20 mA (9-bit input) Ensure to switch S1-2 to "V" before using a voltage input.
H3-09	Analog input A2 function selection.	Selects the multi-function analog input function for terminal A2.
H3-13	Terminal A1/A2 switching	Selects on which terminal the main frequency reference can be input. 0: Use analog input 1 on terminal A1 for main frequency reference. 1: Use analog input 2 on terminal A2 for main frequency reference.
H4-01	Terminal FM monitor selection	Sets the number of the monitor item to be output (U1-□□) at terminal FM/AM.
H4-04	Terminal AM monitor selection	
H4-05	Terminal AM gain	Sets the analog output AM gain. Sets the percentage of the monitor value that is equal to 10V output at terminal AM.

Parameter Number	Name	Description
Motor Protection		
L1-01	Motor protection selection	0: Disabled 1: General-purpose motor protection (fan cooled motor) 2: Inverter motor protection (externally cooled motor) 3: Vector motor protection When the Inverter power supply is turned off, the thermal value is reset, so even if it is enabled, protection may not be effective.
Power Loss Ride Through		
L2-01	Momentary power loss detection	0: Disabled (DC bus undervoltage (UV1) detection) 1: Enabled (Restarted when the power returns within the time set in L2-02. When L2-02 is exceeded, DC bus undervoltage is detected.) 2: Enabled while CPU is operating. (Restarts when power returns during control operations. Does not detect DC bus undervoltage.)
Stall Prevention		
L3-01	Stall prevention selection during accel	0: Disabled (Acceleration as set. With a heavy load, the motor may stall.) 1: Enabled (Acceleration stopped when L3-02 level is exceeded. Acceleration starts again when the current has fallen below the stall prevention level). 2: Intelligent acceleration mode (Using the L3-02 level as a basis, acceleration is automatically adjusted. Set acceleration time is disregarded.)
L3-02	Stall prevention level during accel	Effective when L3-01 is set to 1 or 2. Set as a percentage of Inverter rated current.
L3-04	Stall prevention selection during decel	0: Disabled (Deceleration as set. If deceleration time is too short, a DC bus overvoltage may result.) 1: Enabled (Deceleration is stopped when the DC bus voltage exceeds the stall prevention level. Deceleration restarts when the voltage falls below the stall prevention level again.) 2: Intelligent deceleration mode (Deceleration rate is automatically adjusted so that the Inverter can decelerate in the shortest possible time. The set deceleration time is disregarded.) When a braking option (Braking Unit) is used, always set to 0.
L3-05	Stall prevention selection during running	0: Disabled (Runs as set. With a heavy load, the motor may stall.) 1: Deceleration using deceleration time 1 (C1-02). 2: Deceleration using deceleration time 2 (C1-04.)
L3-06	Stall prevention level during running	Effective when L3-05 is 1 or 2. Set as a percentage of the Inverter rated current.
Fault Restart		

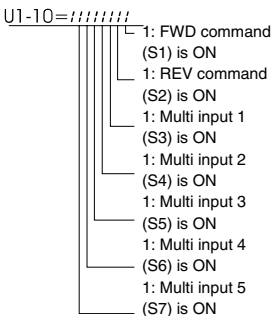
Parameter Number	Name	Description
L5-01	Number of auto restart attempts	Sets the number of auto restart attempts. Automatically restarts after a fault and conducts a speed search from the run frequency.
L5-02	Auto restart operation selection	Sets whether a fault relay is activated during fault restart. 0: No output (Fault relay is not activated.) 1: Output (Fault relay is activated.)
Torque Detection		
L6-01	Load detection selection	0: Load detection disabled. 1: Overload detection only at speed agree; operation continues (alarm). 2: Overload detection continuously during operation; operation continues (alarm). 3: Overload detection only at speed agree; coast to stop (fault). 4: Overload detection continuously during operation; coast to stop (fault). 5: Loss of load detection only at speed agree; operation continues (alarm). 6: Loss of load detection continuously during operation; operation continues (alarm). 7: Loss of Load detection only at speed agree; coast to stop (fault). 8: Loss of Load detection continuously during operation; coast to stop (fault).
L6-02	Load detection level	Inverter rated current is set as 100%.
L6-03	Load detection time	Sets the overload/loss of load detection time.
Monitor Data		
U1-01	Frequency reference in Hz / rpm	
U1-02	Output frequency in Hz / rpm	
U1-03	Output current in A	
U1-06	Output voltage in VAC	
U1-07	DC bus voltage in VDC	
U1-08	Output power in kW	
U1-10	Input terminal status	Shows input ON/OFF status. 

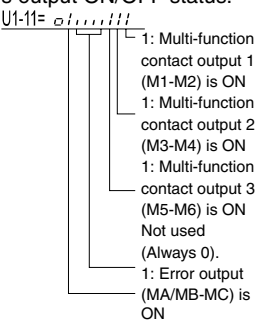
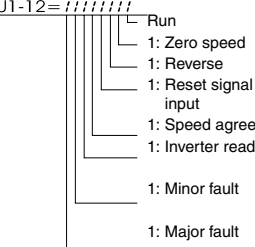
Parameter Number	Name	Description
U1-11	Output terminal status	Shows output ON/OFF status. 
U1-12	Operation status	Inverter operating status. 
U1-13	Cumulative operation time in hrs.	
U1-24	PI feedback value in %	
U1-29	Cumulated energy display 1 in kWh	
U1-30	Cumulated energy display 2 in MWh	
U1-34	OPE fault parameter	
U1-36	PI input volume in %	
U1-37	PI output volume in %	
U1-38	PI setpoint volume in %	
U1-40	Cooling fan operating time in hrs.	
U1-53	PI feedback 2 in %	
Fault Trace Data		
U2-01	Current fault	
U2-02	Last fault	
U2-03	Reference frequency at fault	
U2-04	Output frequency at fault	
U2-05	Output current at fault	
U2-07	Output voltage reference at fault	
U2-08	DC bus voltage at fault	
U2-09	Output power at fault	
U2-11	Input terminal status at fault	
U2-12	Output terminal status at fault	
U2-13	Operation status at fault	
U2-14	Cumulative operation time at fault	
Fault History Data		
U3-01 to U3-04	Last fault to fourth last fault	
U3-05 to U3-08	Cumulative operation time at fault 1 to 4	

Parameter Number	Name	Description
U3-09 to U3-14	Fifth last to tenth last fault	
U3-15 to U3-20	Accumulated time of fifth to tenth fault	
* The following faults are not recorded in the error log: CPF00, 01, 02, 03, UV1, and UV2.		
Digital Input Function Selections (H1-01 to H1-05)		
3	Multi-step speed reference 1	
4	Multi-step speed reference 2	
6	Jog frequency command (higher priority than multi-step speed reference)	
F	Not used (Set when a terminal is not used)	
14	Fault reset (Reset when turned ON)	
19	PI control disable	
20 to 2F	External fault; Input mode: NO contact/NC contact, Detection mode: Normal/during operation	
Digital Output Function Selections (H2-01 and H2-02)		
0	During run 1 (ON: run command is ON or voltage is being output)	
6	Inverter operation ready; READY: After initialization or no faults	
F	Not used. (Set when the terminal is not used.)	
10	Minor fault (Alarm) (ON: Alarm displayed)	
1A	During reverse run (ON: During reverse run)	
1F	Motor overload (OL1, including OH3) pre-alarm (ON: 90% or more of the detection level)	

Troubleshooting

◆ General Faults and Alarms

Faults and Alarms indicate unusual inverter / application conditions.

An alarm does not necessarily switch off the inverter but a message is displayed on the keypad (i.e. a flashing alarm code) and an alarm output can be generated at the multi-function outputs (H2-01 and H2-02) if programmed. An alarm automatically disappears if the alarm condition is not present anymore.

A fault switches the inverter output off immediately, a message is displayed on the keypad and the fault output is switched. The fault must be reset manually after the cause and the RUN signal have been removed.

The following table shows a list of faults and alarms with their corrective actions.

Display	Alarm	Fault	Meaning	Corrective Actions
<i>b u s</i>	○		Option Card Communication Alarm After initial communication was established, the connection was lost.	Check the connections and all user-side software configurations.
<i>CPF00</i>		○	Digital Operator Communication Fault 1/2 • Communication fault between Operator and Inverter • CPU External RAM Fault	<ul style="list-style-type: none"> • Disconnect the Digital Operator and then connect it again. • Cycle the Inverter power supply. • Replace the Inverter.
<i>CPF01</i>				
<i>CPF0×</i>		○	CPF02, CPF03, CPF04 Fault • Baseblock circuit error • EEPROM error • CPU Internal A/D Converter Fault	<ul style="list-style-type: none"> • Perform an initialization to factory defaults. • Cycle the Inverter power supply. • Replace the Inverter.
<i>EF</i>	○		Forward/Reverse Run Commands Input Together Both the forward and the reverse run commands are input simultaneously for 500ms or more. This alarm stops the motor.	Check external sequence logic, so that only one input is activated at a time.
<i>EF0</i>		○	External fault input from Communications Option Card	<ul style="list-style-type: none"> • Check for an external fault condition. • Verify the parameters. • Verify communication signals
<i>EF×</i>	○	○	External fault at terminal Sx (x stands for terminals S3 to S7)	Eliminate the cause of the external fault condition.
<i>ErSr</i>	○		Detected after a fault when a RESET command is input while the RUN command is still active	Remove the RUN signal first and reset the error.
<i>GF</i>		○	Ground Fault The ground current at the Inverter output exceeded 50% of the Inverter rated output current and L8-09=1 (Enabled).	<ul style="list-style-type: none"> • Remove the motor and run the Inverter without the motor. • Check the motor for a phase to ground short. • Check the output current with a clampmeter to verify the DCCT reading. • Check the control sequence for wrong motor contactor signals.
<i>LL3</i>	○	○	Loss of Load Loss of motor load according to the settings of L6-01 to L6-03 has been detected.	<ul style="list-style-type: none"> • Make sure that the settings in L6-02 and L6-03 are appropriate. • Check the mechanical system (mechanical connection of the load, e.g. belt).
<i>oC</i>		○	Over Current The Inverter's output current exceeded the over-current detection level.	<ul style="list-style-type: none"> • Remove the motor and run the Inverter without the motor. • Check the motor for a phase-to-phase short. • Verify the accel/decel times (C1-□□). • Check the Inverter for a phase-to-phase short at the output.
<i>oH</i>		○	Heatsink Overheat L8-03 = 0, 1 or 2 and the temperature of the Inverter's cooling fin exceeded the L8-02 value.	<ul style="list-style-type: none"> • Check for dirt build-up on the fans or heat-sink. • Reduce the ambient temperature around the drive. • Replace the cooling fan(s).
		○	Inverter's Cooling Fan Stopped L8-03 = 3 or 4 and the temperature of the Inverter's cooling fin exceeded the L8-02 value.	

Display	Alarm	Fault	Meaning	Corrective Actions
<i>o H 1</i>		○	Heatsink Overheat The temperature of the Inverter's heatsink exceeded 105 °C.	<ul style="list-style-type: none"> • Check for dirt build-up on the fans or heat-sink. • Reduce the ambient temperature around the drive. • Replace the cooling fan(s).
			Inverter's Cooling Fan Stopped	
<i>o L 1</i>		○	Motor Overload Detected when L1-01 is set to 1,2 or 3 and the Inverter's I ^{2t} value exceeded the motor overload curve. The overload curve is adjustable using parameter E2-01 (Motor Rated Current), L1-01 (Motor Protection Selection) and L2-02 (Motor Protection Time Constant)	<ul style="list-style-type: none"> • Recheck the cycle time and the size of the load as well as the accel/decel times (C1-□□). • Check the V/f characteristics (E1-□□). • Check the setting of Motor Rated Current Setting (E2-01).
<i>o L 2</i>		○	Inverter Overload The Inverter output current exceeded the Inverters's overload capability	<ul style="list-style-type: none"> • Recheck the cycle time and the size of the load as well as the accel/decel times (C1-□□). • Check the V/f Characteristics (E1-□□). • Check if the inverter rated current matches the motor rated current.
<i>o u</i>	○ (only in stop condition)	○	The DC bus voltage has exceeded the overvoltage detection level. Default detection levels are: 200 V class: 410 VDC 400 V class: 820 VDC	<ul style="list-style-type: none"> • Increase the deceleration time (C1-02/04) or connect a braking option. • Check the power supply and decrease the voltage to meet the inverter's specifications. • Check the braking chopper / resistor.
<i>P F</i>		○	Input Phase Loss Too big DC bus voltage ripple. Only detected when L8-05=1 (enabled)	<ul style="list-style-type: none"> • Tighten the input terminal screws • Check the power supply voltage
<i>P U F</i>		○	DC Bus Fuse Open The fuse in the main circuit is blown. Warning: Never run the Inverter after replacing the DC bus fuse without checking for shorted components.	<ul style="list-style-type: none"> • Check the motor and the motor cables for short circuits or insulation failures (phase-to-phase). • Replace the inverter after correcting the fault.
<i>U u 1</i>	○ (only in stop condition)	○	The DC bus voltage is below the Undervoltage Detection Level (L2-05). The default settings are: 200V class: 190 VDC 400 V class: 380 VDC	<ul style="list-style-type: none"> • Check the input voltage. • Check the wiring of the input terminals. • Check the input voltage and the wiring of the input terminals. • Extend the settings in C1-01/03
			Main Circuit MC Operation Failure No MC response during Inverter operation.	Replace the Inverter.
<i>U u 2</i>		○	Control Power Supply Undervoltage Undervoltage of the control circuit while the Inverter was running.	<ul style="list-style-type: none"> • Remove all connection to the control terminals and cycle the power to the Inverter. • Replace the Inverter.

◆ Operator Programming Errors

An Operator Programming Error (OPE) occurs when two or more parameter related to each other are set inappropriately or an individual parameter setting is incorrect. The Inverter does not operate until the parameter setting is corrected; however, no other alarm or fault output will occur. If an OPE occurs, change the related parameter by checking the cause shown in the table below. When an OPE error is displayed, press the ENTER key to see U1-34 (OPE Detected). This monitor displays the parameter that is causing the OPE error.

Display	Meaning	Corrective Actions
<i>o P E 0 1</i>	Inverter kVA Setting Error	Enter the correct kVA setting in o2-04.
<i>o P E 0 2</i>	Parameter Setting is out of its range	Verify the parameter settings.

Display	Meaning	Corrective Actions
oPE03	Multi-function Input Selection Error One of the following errors has been made in the multi-function input (H1-01 to H1-05) settings: <ul style="list-style-type: none"> • Duplicate functions were selected. • UP/DOWN command (setting 10 and 11) were not set simultaneously. • The UP/DOWN commands (10 and 11) and Accel/ decel ramp hold (A) were set at the same time. • More than one of the Speed Search inputs (61, 62, 64) were set simultaneously. • External Baseblock NO (8) and External Baseblock NC (9) were set at the same time. • The UP/DOWN commands (10 and 11) were selected while PI Control (b5-01) was enabled. 	Verify the parameter settings in H1-□□
oPE03	<ul style="list-style-type: none"> • The Emergency Stop Command NO and NC were set at the same time. • Motor Preheat (60) and Motor Preheat 2 (80) were set simultaneously. • Emergency Override FWD (81) and Emergency Override REV (82) are set simultaneously. 	Verify the parameter settings in H1-□□
oPE05	RUN/Reference Command Selection Error The Reference Source Selection b1-01 and/or the RUN Source Selection parameter b1-02 are set to 3 (option board) but no option board is installed.	<ul style="list-style-type: none"> • Verify that the board is installed. Remove the power supply and re-install the option board again • Recheck the setting of b1-01 and b1-02.
oPE09	PI Control Setup Error The following settings have been made at the same time. <ul style="list-style-type: none"> • b5-01 (PI Control Mode Selection) has been set to a value different from 0. • b5-15 (PI Sleep Function Operation Level) has been set to a value different from 0. • b1-03 (Stopping Method Selection) has been set to 2 or 3. 	Check the settings of parameters b5-01, b5-15 and b1-03.
oPE10	V/f Parameter Setting Error	Check parameters (E1-□□). A frequency/voltage value may be set higher than the maximum frequency/voltage.

◆ Autotuning Faults

Autotuning faults are shown below. When the following faults are detected, the fault is displayed on the digital operator and the motor coasts to stop. No fault or alarm outputs will be operated.

Display	Meaning	Corrective Actions
Er - 01	Motor data fault	<ul style="list-style-type: none"> • Check the input data. • Check the Inverter and motor capacity. • Check the motor rated current setting.
Er - 02	Alarm	<ul style="list-style-type: none"> • Check the input data. • Check wiring and the machine. • Check the load.
Er - 03	STOP key input	-
Er - 04	Line-to-Line Resistance Fault <ul style="list-style-type: none"> • Autotuning could not be completed in the specified time • The autotuning result is outside the parameter setting range 	<ul style="list-style-type: none"> • Check the input data. • Check the motor wiring.
End - 3	Rated Current Setting Alarm Displayed after auto-tuning is complete During auto-tuning, the measured value of motor rated current (E2-01) was higher than the set value.	Check the motor rated current value.