

Switch Mode Power Supply S8TS

Block-type Switch mode Power Supply That Mounts to DIN Track

- Power supply range of 60 to 240 W available with just one model (24-V models).
- Easy creation of multi-power supply configurations with different output power supplies connected together (24-V, 12-V, and 5-V models).
- Improve power supply system reliability by creating N+1 redundant systems (24-V and 12-V models).
- Approved by UL/CSA standards, EN60950 (IEC 950), and VDE 0160.



Model Number Structure

Model Number Legend

S8TS- -

1 2 3 4

1. Capacity

060: 60 W
030: 30 W
025: 25 W

2. Output Voltage

24: 24 V
12: 12 V
05: 5 V

3. Structure

None: Screw terminals
F: Connector terminals

4. Bus Line Connectors

None: Basic Block only
E1: S8T-BUS01 and S8T-BUS02 included

Ordering Information

Basic Block

Output voltage	Output current	Screw terminal type		Connector terminal type (See note 3.)	
		With Bus Line Connectors (See note 1.)	Without Bus Line Connectors (See note 2.)	With Bus Line Connectors (See note 1.)	Without Bus Line Connectors (See note 2.)
24 V	2.5 A	S8TS-06024-E1	S8TS-06024	S8TS-06024F-E1	S8TS-06024F
12 V	2.5 A	S8TS-03012-E1	S8TS-03012	S8TS-03012F-E1	S8TS-03012F
5 V	5 A	---	S8TS-02505	---	S8TS-02505F

Bus Line Connector

Type	Number of Connectors	Model number
AC line + DC line bus (For parallel operation)	1 Connector	S8T-BUS01
	10 Connectors (See note 4.)	S8T-BUS11
AC line bus (For series operation or isolated operation)	1 Connector	S8T-BUS02
	10 Connectors (See note 5.)	S8T-BUS12

Note 1. One S8T-BUS01 Connector and one S8T-BUS02 Connector are included as accessories.

2. Bus Line Connectors are ordered separately if necessary.

3. Attached connectors: 2ESDPLM-05P (for output terminal) and 3ESDPLM-03P (for input terminal) made by DINKLE ENTERPRISE.

4. One package contains 10 S8T-BUS01 Connectors.

5. One package contains 10 S8T-BUS02 Connectors.

Specifications

■ Ratings/Characteristics

24/12-V Models (Basic Block: S8TS-06024□/S8TS-03012□)

Item		Single operation	Parallel operation	
Efficiency		24-V models: 75% min.; 12-V models: 70% min. (with rated input, 100% load)		
Input	Voltage	100 to 240 VAC (85 to 264 VAC)		
	Frequency	50/60 Hz (47 to 63 Hz)		
	Current	100 V input	24-V models: 1.0 A max. 12-V models: 0.7 A max.	24-V models: 1.0 A × (No. of Blocks) max. 12-V models: 0.7 A × (No. of Blocks) max.
		200 V input	24-V models: 0.5 A max. 12-V models: 0.4 A max.	24-V models: 0.5 A × (No. of Blocks) max. 12-V models: 0.4 A × (No. of Blocks) max.
	Power factor	24-V models: 0.9 min.; 12-V models: 0.8 min. (with rated input, 100% load) (See note 3.)		
	Leakage current	100 V input	0.35 mA max.	0.35 mA × (No. of Blocks) max.
		240 V input	0.7 mA max.	0.7 mA × (No. of Blocks) max.
Inrush current (25°C, cold start) (See note 4.)	100 V input	25 A max.	25 A × (No. of Blocks) max.	
	200 V input	50 A max.	50 A × (No. of Blocks) max.	
Output (See note 3.)	Voltage adjustment range	24-V models: 22 to 28 V 12-V models: 12 V ±10% (with V.ADJ) (See note 1.)		
	Ripple	2% (p-p) max.		
	Input variation influence	0.5% max. (with 85 to 264 VAC input, 100% load)		
	Load variation influence	2% max. (with rated input, 10% to 100% load)	3% max. (with rated input, 10% to 100% load)	
	Temperature variation influence	0.05%/°C max. (with rated input and output)		
	Startup time (See note 4.)	1,000 ms max.		
	Hold time (See note 4.)	20 ms min. (with 100/200 VAC, rated input)		
Additional functions	Overcurrent protection (See note 4.)	105% to 125% of rated load current, inverted L drop type, automatic reset	100% to 125% of rated load current inverted L drop type, automatic reset	
	Overvoltage protection (See note 4.)	Yes		
	Parallel operation	Yes, 4 Blocks max.		
	N+1 redundant system	Yes, 5 Blocks max.		
	Series operation	Yes		
	Undervoltage indicator (See note 4.)	Yes (color: red)		
Undervoltage detection output (See note 4.)	Yes (open collector output), 30 VDC max., 50 mA max.			
Other	Ambient operating temperature (See note 4.)	Operating: Refer to the derating curve in <i>Engineering Data</i> . Storage: -25 to 65°C (with no icing or condensation)		
	Ambient humidity	Operating: 25% to 85%; Storage: 25% to 90%		
	Dielectric strength	3.0 kVAC, 50/60 Hz for 1 minute (between all inputs and all outputs; detection current: 20 mA)		
		2.0 kVAC, 50/60 Hz for 1 minute (between all inputs and GR terminal; detection current: 20 mA)		
		1.0 kVAC for 1 minute (between all outputs and GR terminal; detection current: 20 mA)		
	Insulation resistance	100 MΩ min. (between all outputs and all inputs, and between all outputs and GR terminal) at 500 VDC		
	Vibration resistance	10 to 55 Hz, 0.375-mm single amplitude for 2 h each in X, Y, and Z directions		
	Shock resistance	150 m/s ² , 3 times each in ±X, ±Y, and ±Z directions		
	Output indicator	Yes (color: green)		
	Electromagnetic interference	Conforms to FCC Class A, EN50081-1		
	EMI	Conforms to EN50081-1/1992		
	Power factor correction	Conforms to EN61000-3-2, EN61000-3-2 A14		
	EMS	Conforms to EN61000-6-2/1999		
	Approved standards	UL: 508 (Listing; Class 2: Per UL1310), 1950, 1604 (Class I, Division 2, Groups A, B, C, D Hazardous Locations) cUL: CSA C22.2 No.14, No.213 (Class I, Division 2, Groups A, B, C, D Hazardous Locations), No. 950 (Class 2) (See note 2.) EN/VDE: EN50178 (=VDE0160), 60950 (=VDE0806)		
Weight	450 g max.	450 g × (No. of Blocks) max.		

Note 1. Refer to page 31 for details on adjusting the output voltage for parallel operation. If set to less than -10%, the undervoltage detection function may operate. Ensure that the output capacity and output current after adjustment do not exceed the rated output capacity and rated output current respectively.

2. Class 2 approval does not apply to parallel operation.
3. The output current is specified at power output terminals.
4. Refer to the explanations of functions on page 28 for details.
5. Be sure to mount End Plates (PFP-M) on both ends of the Power Supply.

5-V Models (Basic Block: S8TS-02505□)

Item		Single operation	
Efficiency (typical)		62% min. (with rated input, 100% load)	
Input	Voltage	100 to 240 VAC (85 to 264 VAC)	
	Frequency	50/60 Hz (47 to 63 Hz)	
	Current	100 V input	0.7 A max.
		200 V input	0.4 A max.
	Power factor	0.8 min. (with rated input, 100% load)	
	Leakage current	100 V input	0.35 mA max.
		240 V input	0.7 mA max.
Inrush current (25°C, cold start) (See note 2.)	100 V input	25 A max.	
	200 V input	50 A max.	
Output (See note 2.)	Voltage adjustment range	5 V ± 10% (with V. ADJ) (See note 1.)	
	Ripple	2% (p-p) max.	
	Input variation influence	0.5% max. (with 85 to 264 VAC input, 100% load)	
	Temperature variation influence	0.05%/°C max. (with rated input and output)	
	Load variation influence	1.5% max. (with rated input, 10% to 100% load)	
	Startup time (See note 3.)	1,000 ms max.	
	Hold time (See note 3.)	20 ms min. (with 100/200 VAC, rated input)	
Additional functions	Overcurrent protection (See note 3.)	105% to 125% of rated load current, inverted L drop type, automatic reset	
	Overvoltage protection (See note 3.)	Yes	
	Parallel operation	No	
	N+1 redundant system	No	
	Series operation	Yes (with the external diode)	
	Undervoltage indicator (See note 3.)	Yes (color: red)	
	Undervoltage detection output (See note 3.)	Yes (open collector output), 30 VDC max., 50 mA max.	
Other	Ambient operating temperature (See note 3.)	Operating: Refer to the derating curve in <i>Engineering Data</i> . Storage: -25 to 65°C (with no icing or condensation)	
	Ambient humidity	Operating: 25% to 85%, Storage: 25% to 90%	
	Dielectric strength	3.0 kVAC, 50/60 Hz for 1 minute (between all inputs and all outputs; detection current: 20 mA)	
		2.0 kVAC, 50/60 Hz for 1 minute (between all inputs and GR terminal; detection current: 20 mA)	
		1.0 kVAC for 1 minute (between all outputs and GR terminal; detection current: 20 mA)	
	Insulation resistance	100 MΩ min. (between all outputs and all inputs, and between all outputs and GR terminal) at 500 VDC	
	Vibration resistance	10 to 55 Hz, 0.375-mm single amplitude for 2 h each in X, Y, and Z directions	
	Shock resistance	150 m/s ² , 3 times each in ±X, ±Y, and ±Z directions	
	Output indicator	Yes (color: green)	
	Electromagnetic interference	Conforms to FCC Class A, EN50081-1	
	EMI	Conforms to EN50081-1/1992	
	Power factor correction	Conforms to EN61000-3-2, EN61000-3-2A14	
	EMS	Conforms to EN61000-6-2/1999	
	Approved standards	UL: 508 (Listing), 1950, 1604 (Class I, Division 2, Groups A, B, C, D Hazardous Locations) cUL: CSA C22.2 No.14, No.213 (Class I, Division 2, Groups A, B, C, D Hazardous Locations), No. 950 EN/VDE: EN50178 (=VDE0160), 60950 (=VDE0806)	
Weight	450 g max.		

- Note 1.** If set to less than -10%, the undervoltage detection function may operate. Ensure that the output capacity and output current after adjustment do not exceed the rated output capacity and rated output current respectively.
- The output current is specified at power output terminals.
 - Refer to the explanations of functions on page 28 for details.
 - Be sure to mount End Plates (PFP-M) on both ends of the Power Supply.

Reference Value

Item	Value	Definition
Reliability (MTBF)	250,000 hrs min.	MTBF stands for Mean Time Between Failures, which is calculated according to the probability of accidental device failures, and indicates reliability of devices. Therefore, it does not necessarily represent the life of the product.
Life expectancy	10 yrs min.	The life expectancy indicates average operating hours under the ambient temperature of 40°C and a load rate of 50%. Normally this is determined by the life expectancy of the built-in aluminum electrolytic capacitor.

Connections

■ Block Diagrams

S8TS-06024□ and S8TS-03012□

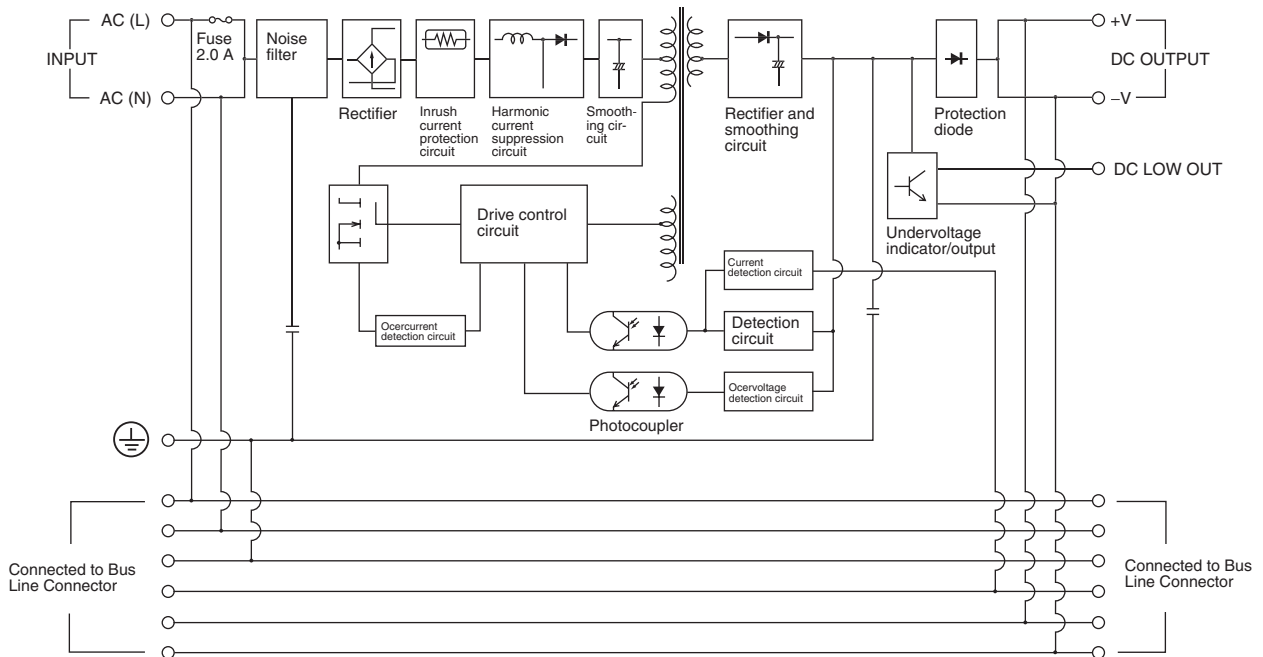

S8TS-02505□

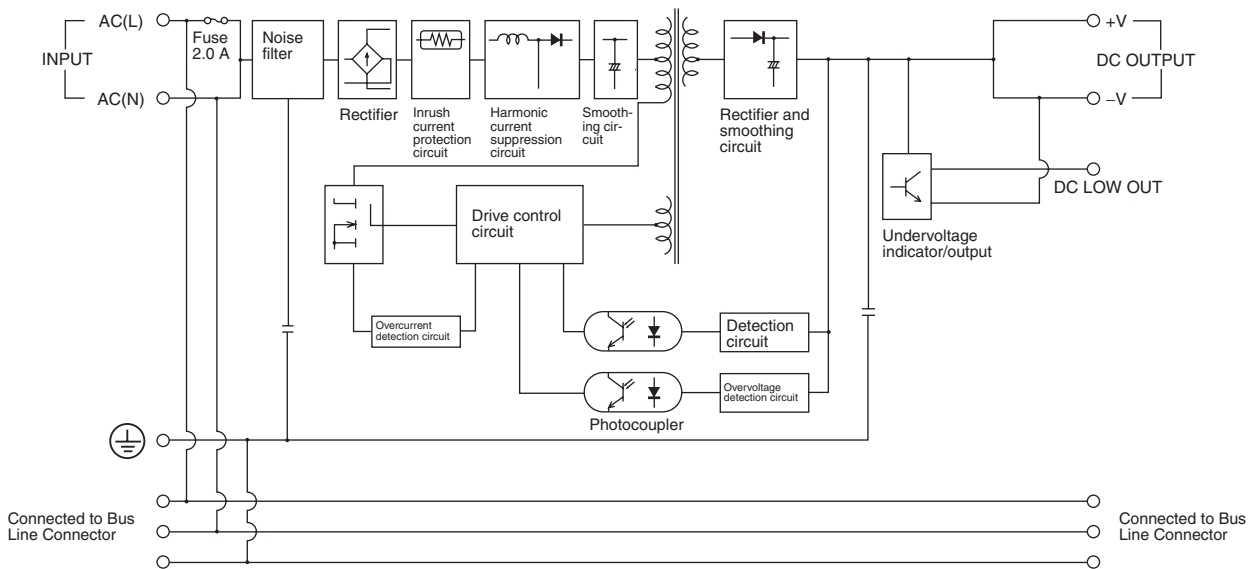

■ Installation

Basic Blocks with Screw Terminals: S8TS-□□□□□

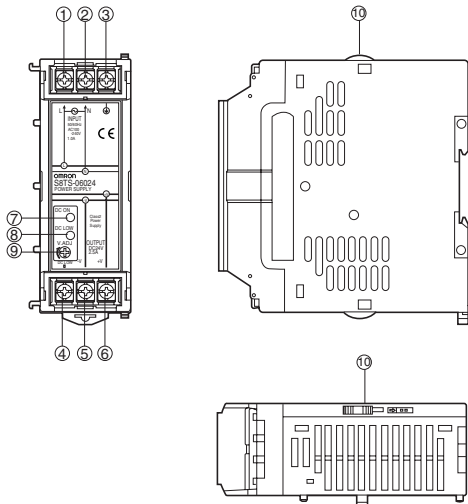

Basic Blocks with Connector Terminals: S8TS-□□□□□F

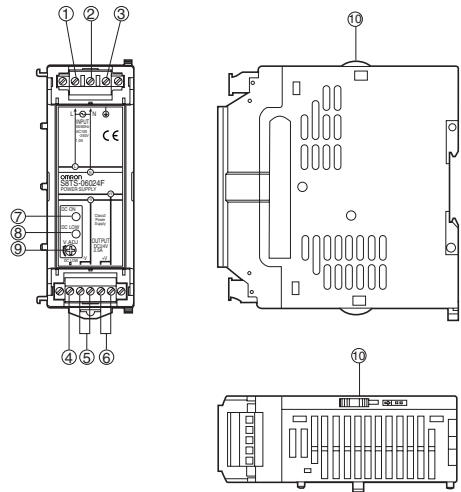

- ① **AC Input Terminal (L)**: Connect an input line to this terminal.
- ② **AC Input Terminal (N)**: Connect an input line to this terminal.
- ③ **Ground Terminal (⊕)**: Connect a ground line to this terminal.
- ④ **Undervoltage Detection Output (DC LOW OUT)**: Open Collector output
- ⑤ **DC Output Terminal (-V)**: Connect load lines to this terminal.
- ⑥ **DC Output Terminal (+V)**: Connect load lines to this terminal.
- ⑦ **Output Indicator (DC ON: Green)**: Lights while DC output is ON.
- ⑧ **Undervoltage Indicator (DC LOW: Red)**: Lights when the voltage at the output terminal drops.
- ⑨ **Output Voltage Adjuster (V.ADJ)**: Use to adjust the voltage.
- ⑩ **Slider**: Slide to the lock side when connecting. Unlock the slider when disconnecting.

S8T-BUS01 Bus Line Connector (AC Line + DC Line Bus)

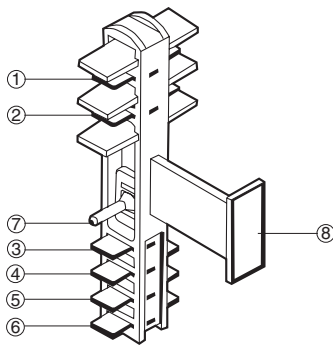

S8T-BUS02 Bus Line Connector (AC Line Bus)

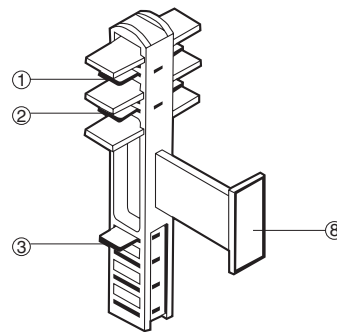

- ① AC Input Terminal (L)
- ② AC Input Terminal (N)
- ③ Ground Terminal (⊕)
- ④ Parallel Operation Signal Terminal
- ⑤ DC Output Terminal (+V)
- ⑥ DC Output Terminal (-V)
- ⑦ Selector
- ⑧ Projected Indicator Section

Operation

Maximum Number of Blocks That Can Be Linked

Basic Blocks can be linked using Bus Line Connectors.

Increasing Output Capacity

Models	Number of Blocks	N+1 Redundant System
S8TS-06024□	4 Blocks	Yes, 5 Blocks
S8TS-03012□	4 Blocks	Yes, 5 Blocks
S8TS-02505□	No	No

N+1 Redundant Systems

To ensure stable operation when there is a failure in one of the Blocks, use within the derating curve for N+1 redundant systems.

Multi-output Power Supply

Up to 4 Basic Blocks with different output voltage specifications can be linked.

Selecting Bus Line Connectors

Select Bus Line Connectors according to the linking method as follows:

- Using parallel operation:

S8T-BUS01 (DC line connected)

The S8T-BUS01 Bus Line Connector is equipped with a selector to prevent erroneous connection of Blocks with different output voltage specifications. Slide the selector to the output voltage for parallel operation.

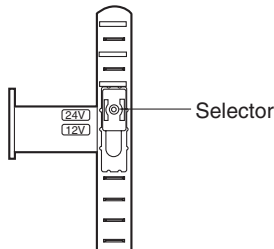

- Not using parallel operation:

S8T-BUS02 (DC line not connected)

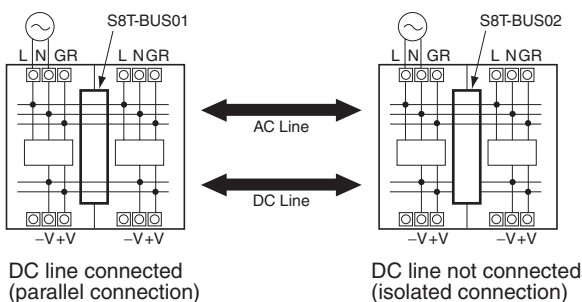

Note: Series operation is possible with different specifications, but the current that flows to the load must not exceed the rated output current of any Block.

Mounting and Removing Bus Line Connectors

Pay attention to the following points to maintain electrical characteristics.

- Do not insert/remove the Connectors more than 20 times.
- Do not touch the Connector terminals.
- To remove the Connectors, insert a flat-bladed screwdriver alternately at both ends.

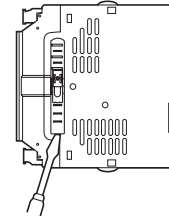

Wiring Linked Blocks

When linking Blocks together, wire input lines to one Block only, otherwise inputs may be shorted internally resulting in damage to the Block.

Do not wire inputs to more than one

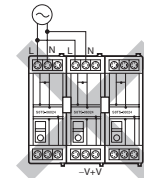

Do not cross-wire Blocks or wire between a Block and another device. If the rated current is exceeded, Bus Line Connectors may be damaged.

Do not use cross-wire Blocks.

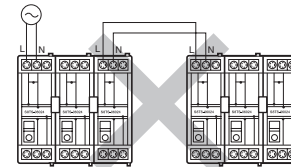

When Basic Blocks are linked together, it is necessary to wire the GR terminal of only one Block, not all the Blocks.

Series Operation and ± Output

Using 2 Basic Blocks enables series operation and the use of ± output. An external diode is not required for S8TS-06024□ and S8TS-03012□ models but is required for S8TS-02505□ models. Use the following as a rough guide for selecting the diode.

Type	Schottky barrier diode
Withstand voltage (V_{RRM})	At least twice the rated output voltage
Current with normal di-rection (I_F)	At least twice the rated output current

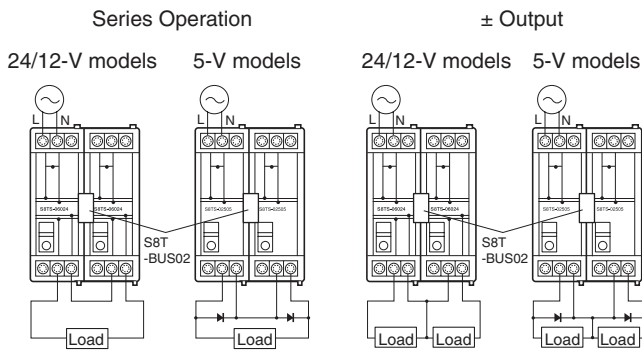

Adjusting Output Voltage for Parallel Operation

The Blocks are factory-set to the rated output voltage. When adjusting voltages, set the same values for Blocks with V.ADJ before linking them together. Adjust the set values within the limits given in the following table.

Model number	Difference between output voltages
S8TS-06024□	0.24 V max.
S8TS-03012□	0.12 V max.

Do not adjust voltages after Blocks are linked together. The output voltage may become unstable.

Inrush Current

The inrush current per Basic Block is 25 A max. at 100 VAC and 50 A max. at 200 VAC. When N Blocks are linked together, the inrush current will be equal to N times that for 1 Basic Block. Be sure to use a fuse with the appropriate fusing characteristics or a breaker with the appropriate tripping characteristics.

Leakage Current

The leakage current per Basic Block is 0.35 mA at 100 VAC and 0.7 mA at 240 VAC. When N Blocks are linked together, the leakage current will be equal to N times that for 1 Basic Block.

Mounting

Mounting Direction

Standard mounting	Yes
Face-up mounting	No
Other mounting methods	No

Use standard mounting only. Using any other mounting method will prevent proper heat dissipation and may result in deterioration or damage of internal elements.

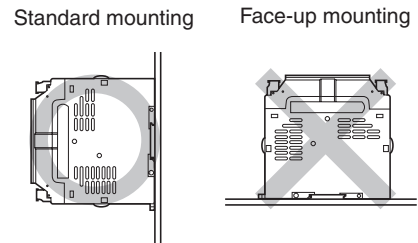

Engineering Data

Derating Curves

Parallel Operation and Side-by-side Mounting

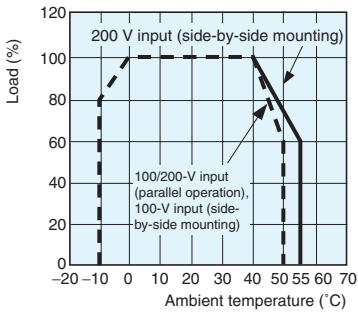
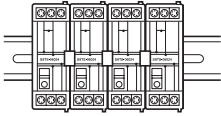

Single Operation with Spaces between Blocks

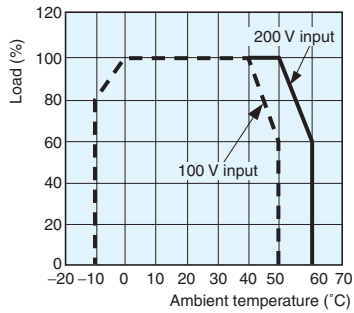
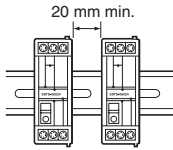

N+1 Redundant System

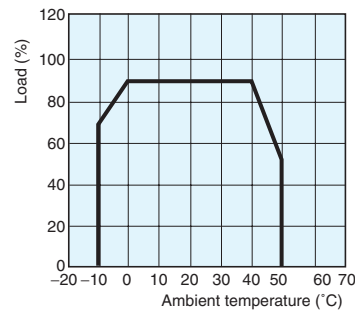

Note: If there is a derating problem, use forced air-cooling.
The ambient temperature is specified for a point 50 mm below the power supply.

Overload Protection

The Power Supply is provided with an overload protection function that protects the load and the power supply from possible damage by overcurrent. When the output current rises above 105% min. of the rated current (100% min. of the rated current for parallel operation), the protection function is triggered, decreasing the output voltage. When the output current falls within the rated range, the overload protection function is automatically cleared.

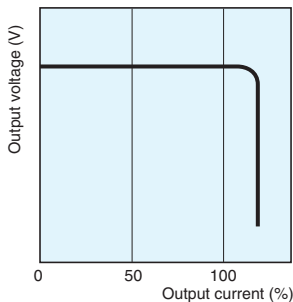

Note: Do not allow the short-circuited or overcurrent state to continue for more than 20 s, otherwise it may damage the element.

Overvoltage Protection

The Power Supply is provided with an overvoltage protection function that protects the load and the Power Supply from possible damage by overvoltage. When an excessive voltage is output, the output voltage is shut OFF. Reset the Power Supply by turning it OFF for at least 1 minute and then turning it back ON again.

24-V Models

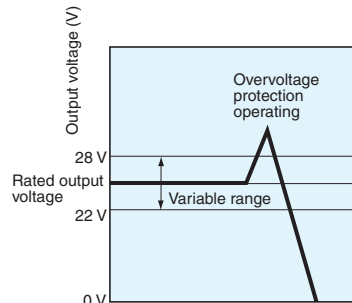

12-V and 5-V Models

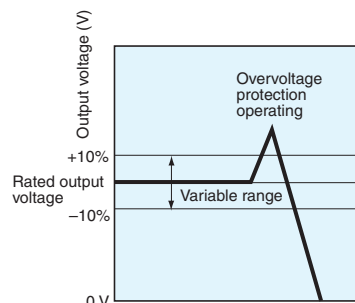

Note: Do not turn ON the power again until the cause of the overvoltage has been removed.

■ Inrush Current, Startup Time, Hold Time

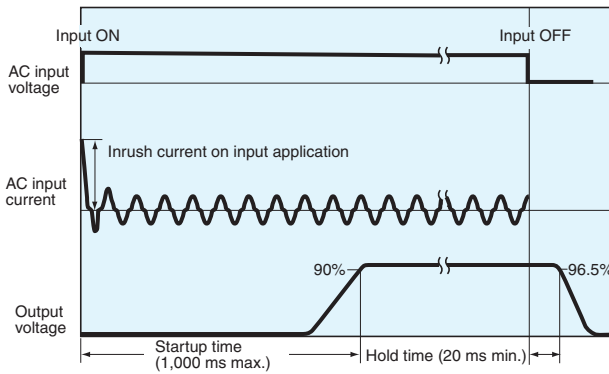

■ Undervoltage Indicator and Undervoltage Detection Output

When a drop in the output voltage is detected, the red indicator (DC LOW) lights and transistor (DC LOW: OUT) output turns ON. The detection voltage is set to approximately 80% (75% to 90%) of the rated output voltage.

This function monitors the voltage at the output terminals. For accurate confirmation of the output status, measure the voltage at the output terminal.

Status of indicator	Voltage status	Output status (See note 1.)
Green: ● DC ON Red: ○ DC LOW	Higher than approx. 80% of the rated output voltage	ON
Green: ● DC ON (See note 2.) Red: ● DC LOW	Less than approx. 80% of the rated output voltage	OFF
Green: ○ DC ON Red: ○ DC LOW	Close to 0 V	OFF

Note 1: Transistor output: Open collector
 30 VDC max., 50 mA max.
 ON residual voltage: 2 V max.
 OFF leakage current: 0.1 mA max.

2: The indicators become dimmer as the output voltage approaches 0 V.

Undervoltage Output

Blocks with Screw Terminals Blocks with Connector Terminals

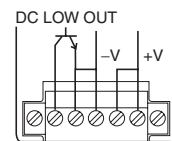
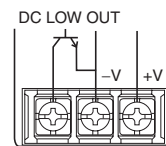

Dimensions

Note: All units are in millimeters unless otherwise indicated.

S8TS-□□□□□

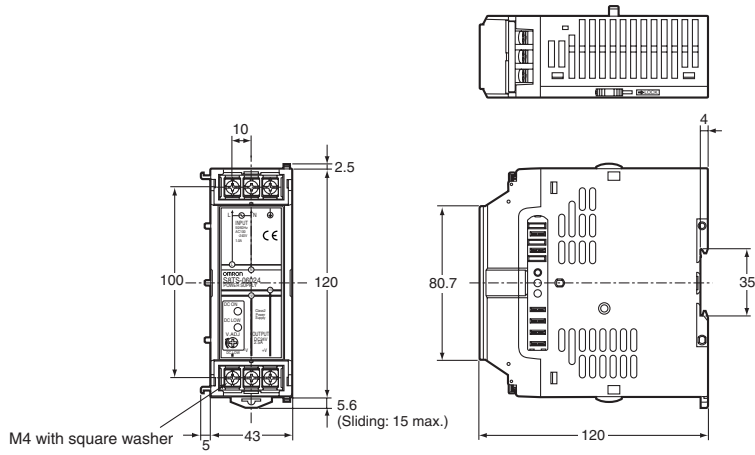
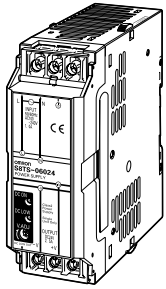

S8TS-□□□□□F

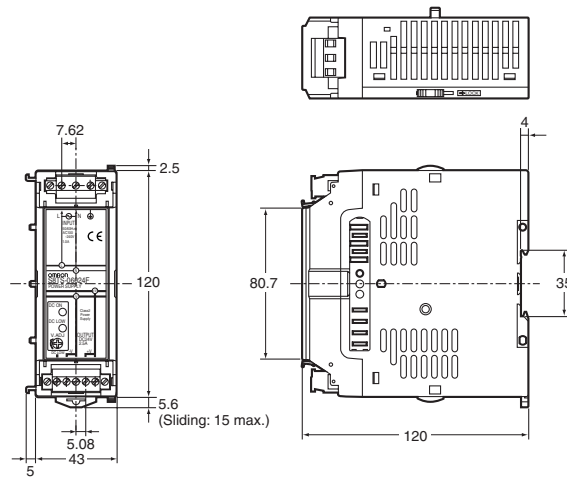
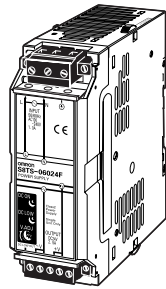

■ Mounting Track (Order Separately)

DIN Track

PFP-100N
PFP-50N

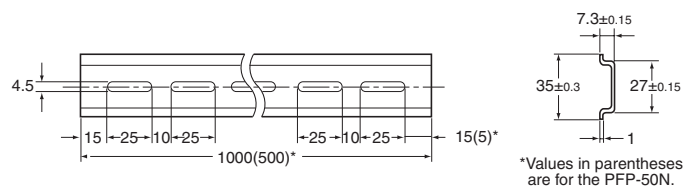
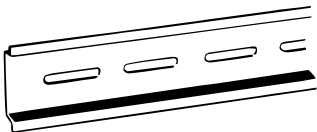

PFP-100N2

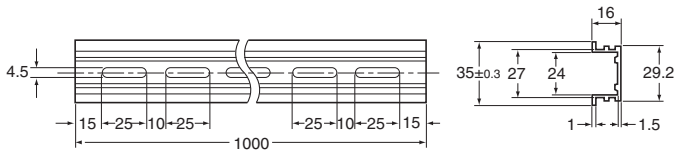
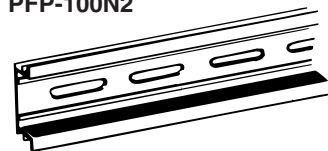

End Plate

PFP-M

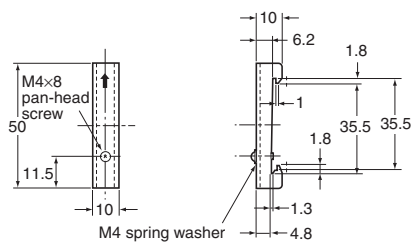
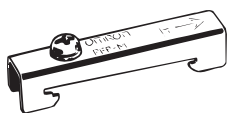

Precautions

⚠ WARNING

Do not attempt to take any Block apart or touch the interior of a Block while the power is being supplied. Doing so may result in electric shock.

Do not link or separate any Blocks while the power is being supplied. Doing so may result in electric shock.

Do not remove the connector cover on unused Bus Line Connectors. Doing so may result in electric shock.

Close the terminal covers before use. Not doing so may result in electric shock.

⚠ Caution

When linking Blocks, lock the sliders and track stoppers.

When linking Blocks, wire the input line for 1 Block only. Otherwise, inputs may be shorted internally resulting in damage to the Blocks.

The tightening torque for terminal screws is 1.08 N·m. The tightening torque for connector screws and screw flanges is 0.30 N·m. Loose screws may result in fire.

Do not touch the Power Supply while power is supplied or immediately after power is turned OFF. The Power Supply becomes hot and touching it may result in injury.

Mounting

To improve the long-term reliability of devices, give due consideration to heat dissipation when mounting. With the S8TS, heat is dissipated by natural convection. Mount Blocks in a way that allows convection in the atmosphere around them.

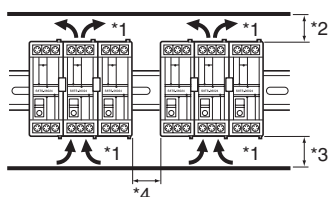

- *1. Convection of air
- *2. 75 mm min.
- *3. 75 mm min.
- *4. 10 mm min.

When cutting out holes for mounting, make sure that cuttings do not enter the interior of the products.

Wiring

Be sure to wire I/O terminals correctly. When tightening the terminals, do not exert a force of 100 N or more on terminal blocks or connector terminals.

With Blocks with connector terminals, the current for 1 terminal must not exceed 7.5 A. If a higher current is required, use 2 terminals.

Recommended Wire Size for Single Operation

Model	Recommended wire size
S8TS-06024 S8TS-03012	AWG 14 to 20 (cross-sectional area: 0.517 to 2.081 mm ²)
S8TS-02505	AWG 14 to 18 (cross-sectional area: 0.823 to 2.081 mm ²)
S8TS-06024F S8TS-03012F	AWG 12 to 20 (cross-sectional area: 0.517 to 3.309 mm ²)
S8TS-02505F	AWG 12 to 18 (cross-sectional area: 0.823 to 3.309 mm ²)

Recommended Wire Size for Parallel Operation

Model	Recommended wire size	
S8TS-06024 S8TS-03012	For 2 Units connected in parallel	AWG 14 to 18 (cross-sectional area: 0.823 to 2.081 mm ²)
	For 3 Units connected in parallel	AWG 14 to 16 (cross-sectional area: 1.309 to 2.081 mm ²)
	For 4 Units connected in parallel	AWG 14 (cross-sectional area: 2.081 mm ²)
S8TS-06024F S8TS-03012F	For 2 Units connected in parallel	AWG 12 to 18 (cross-sectional area: 0.823 to 3.309 mm ²)
	For 3 Units connected in parallel	AWG 12 to 16 (cross-sectional area: 1.309 to 3.309 mm ²)
	For 4 Units connected in parallel	AWG 12 to 14 (cross-sectional area: 2.081 to 3.309 mm ²)

Blocks with Connector Terminals

- When using Blocks with connector terminals, the current for 1 terminal must not exceed 7.5 A. If a higher current is required, use 2 terminals.
- Do not insert/remove AC input connectors or DC output connector more than 20 times.

Installation Environment

Do not use the Power Supply in locations subject to shocks or vibrations. Be sure to mount End Plates (PFP-M) on both ends of the Power Supply. Install the Power Supply well away from any sources of strong, high-frequency noise.

Operating and Storage Environments

Do not use or store the Power Supply in the following locations. Doing so may result in failure, malfunction, or deterioration of performance characteristics.

- Do not use in locations subject to direct sunlight.
- Do not use in locations where the ambient temperature exceeds the range of the derating curve.
- Do not use in locations where the humidity is outside the range 25% to 85%, or locations subject to condensation due to sudden temperature changes.
- Do not store in locations where the ambient temperature is outside the range -25 to 65°C or where the humidity is outside the range 25% to 95%.
- Do not use in locations where liquids, foreign matter, corrosive gases, or flammable gases may enter the interior of products.

Charging Batteries

If a battery is connected as the load, provide an overcurrent control circuit and an overvoltage protective circuit.

Output Voltage Adjuster (V.ADJ)

Do not exert excessive force on the output voltage adjuster (V.ADJ). Doing so may break the adjuster.

Setting the adjuster to a setting less than 10% may cause the under-voltage detection function to operate.

Bus Line Connectors

Do not apply sudden shocks (e.g., by dropping) to the Bus Line Connectors. Doing so may result in damage.

DIN Track Mounting

To mount the Block on a DIN track, hook portion (A) of the Block onto the track and press the Block in direction (B).

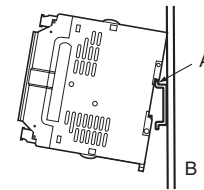

To dismount the Block, pull down portion (C) with a flat-blade screwdriver and pull out the Block.

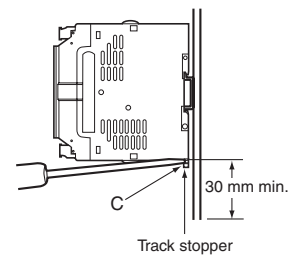

No Output Voltage

If there is no output voltage, it is possible that overcurrent protection or overvoltage protection is operating. It is also possible that the latch protection circuit is operating due to the application of a large surge, such as lightning surge. Confirm the 2 points below. If there is still no output voltage, consult your OMRON representative.

- Checking for Overcurrent Protection:
Separate the load line and confirm that it is not in an overcurrent state (including short-circuits).
- Checking for Overvoltage Protection or Latch Protection:
Turn the input power supply OFF, and then turn it ON again after 1 minute or more has elapsed.

ALL DIMENSIONS SHOWN ARE IN MILLIMETERS.

To convert millimeters into inches, multiply by 0.03937. To convert grams into ounces, multiply by 0.03527.

Cat. No. T022-E1-03

In the interest of product improvement, specifications are subject to change without notice.