

CompoNet

CS1W-CRM21/CJ1W-CRM21

CompoNet Master Units

Operation Manual

Produced September 2006

Notice:

OMRON products are manufactured for use according to proper procedures by a qualified operator and only for the purposes described in this manual.

The following conventions are used to indicate and classify precautions in this manual. Always heed the information provided with them. Failure to heed precautions can result in injury to people or damage to property.

 **DANGER** Indicates an imminently hazardous situation which, if not avoided, will result in death or serious injury. Additionally, there may be severe property damage.

 **WARNING** Indicates a potentially hazardous situation which, if not avoided, could result in death or serious injury. Additionally, there may be severe property damage.

 **Caution** Indicates a potentially hazardous situation which, if not avoided, may result in minor or moderate injury, or property damage.

OMRON Product References

All OMRON products are capitalized in this manual. The word “Unit” is also capitalized when it refers to an OMRON product, regardless of whether or not it appears in the proper name of the product.

The abbreviation “Ch,” which appears in some displays and on some OMRON products, often means “word” and is abbreviated “Wd” in documentation in this sense.

The abbreviation “PLC” means Programmable Controller. “PC” is used, however, in some Programming Device displays to mean Programmable Controller.

Visual Aids

The following headings appear in the left column of the manual to help you locate different types of information.

Note Indicates information of particular interest for efficient and convenient operation of the product.

1,2,3... 1. Indicates lists of one sort or another, such as procedures, checklists, etc.

© OMRON, 2006

All rights reserved. No part of this publication may be reproduced, stored in a retrieval system, or transmitted, in any form, or by any means, mechanical, electronic, photocopying, recording, or otherwise, without the prior written permission of OMRON.

No patent liability is assumed with respect to the use of the information contained herein. Moreover, because OMRON is constantly striving to improve its high-quality products, the information contained in this manual is subject to change without notice. Every precaution has been taken in the preparation of this manual. Nevertheless, OMRON assumes no responsibility for errors or omissions. Neither is any liability assumed for damages resulting from the use of the information contained in this publication.

TABLE OF CONTENTS

PRECAUTIONS	xv
1 Intended Audience	xvi
2 General Precautions	xvi
3 Safety Precautions	xvi
4 Operating Environment Precautions	xvii
5 Application Precautions	xviii
6 Conformance to EC Directives	xx
SECTION 1	
Overview	1
1-1 CompoNet Networks	2
1-2 CompoNet Network Specifications	7
1-3 Devices in a CompoNet Network	14
1-4 Overview of Design Flow	26
1-5 Overview of Operating Procedure	27
1-6 Design and Operating Procedure Examples	28
SECTION 2	
Master Units	39
2-1 Master Unit Specifications	40
SECTION 3	
Wiring Configurations	49
3-1 Wiring Formations	50
3-2 CompoNet Network Wiring	51
SECTION 4	
Installation and Wiring	65
4-1 Installation	66
4-2 Connecting Cables	74
4-3 Preparing Pressure-welded Connectors	84
4-4 Power Supply Wiring	95
4-5 Connecting External I/O for Slave Units	110
SECTION 5	
Remote I/O Communications	119
5-1 Exchanging Data with the CPU Unit	120
5-2 Allocations to Slave Units	129
5-3 Remote I/O Communications Performance	156

TABLE OF CONTENTS

SECTION 6

Message Communications	167
6-1 Message Communications	168
6-2 Overview of FINS Commands and Responses	170
6-3 Using FINS Message Communications	172
6-4 Sending Explicit Messages	175

SECTION 7

Troubleshooting	183
7-1 Handling Errors	184
7-2 Error History Function	190

Appendix

A FINS Commands Addressed to CompoNet Master Units and Responses	195
--	-----

Index	207
--------------------	------------

Revision History	211
-------------------------------	------------

About this Manual:

This manual describes the installation and operation of the CS1W-CRM21 and CJ1W-CRM21 CompoNet Master Units and includes the sections described below.

Please read this manual carefully and be sure you understand the information provided before attempting to install or operate a CompoNet Master Unit. Be sure to read the precautions provided in the following section. Also be sure to read the *CompoNet Slave Unit Operation Manual* (see following table) together with this manual.

Precautions provides general precautions for using the CompoNet Master Unit, Programmable Controller, and related devices.

Section 1 provides an overview of CompoNet Networks.

Section 2 provides the specifications of the CompoNet Master Units.

Section 3 describes the configurations of CompoNet Networks.

Section 4 describes how to install and wire a CompoNet Network.

Section 5 describes the remote I/O communications that are possible with CompoNet Networks.

Section 6 describes the message communications that are possible with CompoNet Networks.

Section 7 provides information on dealing with problems that might occur with CompoNet Master Units.

Related Manuals:

Cat. No.	Models	Name	Description
W456 (this manual)	CS1W-CRM21 and CJ1W-CRM21	CS/CJ-series CompoNet Master Units Operation Manual	Provides an overview of CompoNet Networks, communications specifications, wiring methods, and CompoNet Master Unit functions.
W457	CRT1-ID16(-1)/OD16(-1) CRT1B-ID/OD/MD□□□□(-1) CRT1-AD04/DA02 CRS1-RPT01	CompoNet Slave Units and Repeater Unit Operation Manual	Provides the specifications of CompoNet Slave Units and Repeater Unit.



WARNING Failure to read and understand the information provided in this manual may result in personal injury or death, damage to the product, or product failure. Please read each section in its entirety and be sure you understand the information provided in the section and related sections before attempting any of the procedures or operations given.

Read and Understand this Manual

Please read and understand this manual before using the product. Please consult your OMRON representative if you have any questions or comments.

Warranty and Limitations of Liability

WARRANTY

OMRON's exclusive warranty is that the products are free from defects in materials and workmanship for a period of one year (or other period if specified) from date of sale by OMRON.

OMRON MAKES NO WARRANTY OR REPRESENTATION, EXPRESS OR IMPLIED, REGARDING NON-INFRINGEMENT, MERCHANTABILITY, OR FITNESS FOR PARTICULAR PURPOSE OF THE PRODUCTS. ANY BUYER OR USER ACKNOWLEDGES THAT THE BUYER OR USER ALONE HAS DETERMINED THAT THE PRODUCTS WILL SUITABLY MEET THE REQUIREMENTS OF THEIR INTENDED USE. OMRON DISCLAIMS ALL OTHER WARRANTIES, EXPRESS OR IMPLIED.

LIMITATIONS OF LIABILITY

OMRON SHALL NOT BE RESPONSIBLE FOR SPECIAL, INDIRECT, OR CONSEQUENTIAL DAMAGES, LOSS OF PROFITS OR COMMERCIAL LOSS IN ANY WAY CONNECTED WITH THE PRODUCTS, WHETHER SUCH CLAIM IS BASED ON CONTRACT, WARRANTY, NEGLIGENCE, OR STRICT LIABILITY.

In no event shall the responsibility of OMRON for any act exceed the individual price of the product on which liability is asserted.

IN NO EVENT SHALL OMRON BE RESPONSIBLE FOR WARRANTY, REPAIR, OR OTHER CLAIMS REGARDING THE PRODUCTS UNLESS OMRON'S ANALYSIS CONFIRMS THAT THE PRODUCTS WERE PROPERLY HANDLED, STORED, INSTALLED, AND MAINTAINED AND NOT SUBJECT TO CONTAMINATION, ABUSE, MISUSE, OR INAPPROPRIATE MODIFICATION OR REPAIR.

Application Considerations

SUITABILITY FOR USE

OMRON shall not be responsible for conformity with any standards, codes, or regulations that apply to the combination of products in the customer's application or use of the products.

At the customer's request, OMRON will provide applicable third party certification documents identifying ratings and limitations of use that apply to the products. This information by itself is not sufficient for a complete determination of the suitability of the products in combination with the end product, machine, system, or other application or use.

The following are some examples of applications for which particular attention must be given. This is not intended to be an exhaustive list of all possible uses of the products, nor is it intended to imply that the uses listed may be suitable for the products:

- Outdoor use, uses involving potential chemical contamination or electrical interference, or conditions or uses not described in this manual.
- Nuclear energy control systems, combustion systems, railroad systems, aviation systems, medical equipment, amusement machines, vehicles, safety equipment, and installations subject to separate industry or government regulations.
- Systems, machines, and equipment that could present a risk to life or property.

Please know and observe all prohibitions of use applicable to the products.

NEVER USE THE PRODUCTS FOR AN APPLICATION INVOLVING SERIOUS RISK TO LIFE OR PROPERTY WITHOUT ENSURING THAT THE SYSTEM AS A WHOLE HAS BEEN DESIGNED TO ADDRESS THE RISKS, AND THAT THE OMRON PRODUCTS ARE PROPERLY RATED AND INSTALLED FOR THE INTENDED USE WITHIN THE OVERALL EQUIPMENT OR SYSTEM.

PROGRAMMABLE PRODUCTS

OMRON shall not be responsible for the user's programming of a programmable product, or any consequence thereof.

Disclaimers

CHANGE IN SPECIFICATIONS

Product specifications and accessories may be changed at any time based on improvements and other reasons.

It is our practice to change model numbers when published ratings or features are changed, or when significant construction changes are made. However, some specifications of the products may be changed without any notice. When in doubt, special model numbers may be assigned to fix or establish key specifications for your application on your request. Please consult with your OMRON representative at any time to confirm actual specifications of purchased products.

DIMENSIONS AND WEIGHTS

Dimensions and weights are nominal and are not to be used for manufacturing purposes, even when tolerances are shown.

PERFORMANCE DATA

Performance data given in this manual is provided as a guide for the user in determining suitability and does not constitute a warranty. It may represent the result of OMRON's test conditions, and the users must correlate it to actual application requirements. Actual performance is subject to the OMRON Warranty and Limitations of Liability.

ERRORS AND OMISSIONS

The information in this manual has been carefully checked and is believed to be accurate; however, no responsibility is assumed for clerical, typographical, or proofreading errors, or omissions.

PRECAUTIONS

This section provides general precautions for using the CS1W-CRM21 and CJ12-CRM21 CompoNet Master Units.

The information contained in this section is important for the safe and reliable application of the CompoNet Master Units. You must read this section and understand the information contained before attempting to set up or operate a CompoNet Network using CompoNet Master Units.

1	Intended Audience	xvi
2	General Precautions	xvi
3	Safety Precautions	xvi
4	Operating Environment Precautions	xvii
5	Application Precautions	xviii
6	Conformance to EC Directives	xx
6-1	Applicable Directives	xx
6-2	Concepts	xx
6-3	Conformance to EC Directives	xx

1 Intended Audience

This manual is intended for the following personnel, who must also have knowledge of electrical systems (an electrical engineer or the equivalent).

- Personnel in charge of installing FA systems.
- Personnel in charge of designing FA systems.
- Personnel in charge of managing FA systems and facilities.

2 General Precautions

The user must operate the product according to the performance specifications described in the operation manuals.

Before using the product under conditions which are not described in the manual or applying the product to nuclear control systems, railroad systems, aviation systems, vehicles, combustion systems, medical equipment, amusement machines, safety equipment, and other systems, machines, and equipment that may have a serious influence on lives and property if used improperly, consult your OMRON representative.

Make sure that the ratings and performance characteristics of the product are sufficient for the systems, machines, and equipment, and be sure to provide the systems, machines, and equipment with double safety mechanisms.

This manual provides information for programming and operating the Unit. Be sure to read this manual before attempting to use the Unit and keep this manual close at hand for reference during operation.

 **WARNING** It is extremely important that a PLC and all PLC Units be used for the specified purpose and under the specified conditions, especially in applications that can directly or indirectly affect human life. You must consult with your OMRON representative before applying a PLC System to the above-mentioned applications.

3 Safety Precautions

 **WARNING** Do not attempt to take any Unit apart while the power is being supplied. Doing so may result in electric shock.

 **WARNING** Do not touch any of the terminals or terminal blocks while the power is being supplied. Doing so may result in electric shock.

 **WARNING** Fail-safe measures must be taken by the customer to ensure safety in the event of incorrect, missing, or abnormal signals caused by broken signal lines, momentary power interruptions, or other causes. Serious accidents may result from abnormal operation if proper measures are not provided.

 **WARNING** Provide safety measures in external circuits (i.e., not in the Programmable Controller), including the following items, to ensure safety in the system if an abnormality occurs due to malfunction of the PLC or another external factor affecting the PLC operation. (“PLC” includes CPU Units, other Units mounted in the PLC, and Remote I/O Terminals) Not doing so may result in serious accidents.

- Emergency stop circuits, interlock circuits, limit circuits, and similar safety measures must be provided in external control circuits.
- The PLC will turn OFF all outputs when its self-diagnosis function detects any error or when a severe failure alarm (FALS) instruction is executed. As a countermeasure for such errors, external safety measures must be provided to ensure safety in the system.
- The PLC outputs may remain ON or OFF due to deposits on or burning of the output relays, or destruction of the output transistors. As a countermeasure for such problems, external safety measures must be provided to ensure safety in the system.
- When the 24-V DC output (service power supply) is overloaded or short-circuited, the voltage may drop and result in the outputs being turned OFF. As a countermeasure for such problems, external safety measures must be provided to ensure safety in the system.

 **Caution** Execute online editing only after confirming that no adverse effects will be caused by extending the cycle time. Otherwise, the input signals may not be readable.

 **Caution** Confirm safety at the destination node before changing or transferring to another node the contents of a program, the PLC Setup, I/O tables, or I/O memory. Changing or transferring any of these without confirming safety may result in unexpected equipment operation.

4 Operating Environment Precautions

 **Caution** Do not operate the control system in the following locations:

- Locations subject to direct sunlight.
- Locations subject to temperatures or humidity outside the range specified in the specifications.
- Locations subject to condensation as the result of severe changes in temperature.
- Locations subject to corrosive or flammable gases.
- Locations subject to dust (especially iron dust) or salts.
- Locations subject to exposure to water, oil, or chemicals (including acids).
- Locations subject to shock or vibration.

 **Caution** Take appropriate and sufficient countermeasures when installing systems in the following locations:

- Locations subject to static electricity or other forms of noise.
- Locations subject to strong electromagnetic fields.
- Locations subject to possible exposure to radioactivity.
- Locations close to power supplies.

 **Caution** The operating environment of the PLC System can have a large effect on the longevity and reliability of the system. Improper operating environments can lead to malfunction, failure, and other unforeseeable problems with the PLC System. Make sure that the operating environment is within the specified conditions at installation and remains within the specified conditions during the life of the system.

5 Application Precautions

Observe the following precautions when using a CompoNet Network.

- Always separate Flat Cables (Standard and Sheathed) for different CompoNet lines by at least 5 mm to prevent unstable operation due to interference. Do not bundle Flat Cables.
- Fail-safe measures must be taken by the customer to ensure safety in the event of incorrect, missing, or abnormal signals caused by broken signal lines, momentary power interruptions, or other causes.
- Interlock circuits, limit circuits, emergency stop circuits, and similar safety measures in external circuits (i.e., not in the Programmable Controller) must be provided by the customer.
- Always configure control circuits so that they turn ON power to the I/O Slave Units before turning ON power to the PLC. If the PLC power supply is turned ON first, normal operation will not be possible temporarily.
- Do not attempt to disassemble, repair, or modify any Units. Any attempt to do so may result in malfunction, fire, or electric shock.
- When installing the Unit, ground to 100 Ω min.
- Make sure that all the Backplane mounting screws, Slave Unit mounting screws, terminal block screws, and cable connector screws are tightened to the torque specified in the relevant manuals. Incorrect tightening torque may result in malfunction.
- Wire all connections correctly according to instructions in this manual.
- Confirm the orientation and polarity before connecting terminal blocks or connectors.
- Confirm voltage specifications before wiring communications lines, power supplies, and I/O circuits. Incorrect specification may result in malfunctions.
- Install external breakers and take other safety measures against short-circuiting in external wiring. Insufficient safety measures against short-circuiting may result in burning.
- Leave the label attached to the Unit when wiring. Removing the label may result in malfunction if foreign matter enters the Unit.
- Remove the label after the completion of wiring to ensure proper heat dissipation. Leaving the label attached may result in malfunction.

- Use crimp terminals for wiring. Do not connect bare stranded wires directly to terminals. Connection of bare stranded wires may result in burning.
- Double-check all wiring and switch settings before turning ON the power supply. Incorrect wiring may result in burning.
- Make sure that the terminal blocks, connectors, expansion cables, communications cables, and other items with locking devices are properly locked into place. Improper locking may result in malfunction.
- Disconnect the functional ground terminal when performing withstand voltage tests. Not disconnecting the functional ground terminal may result in burning.
- Always use the power supply voltages specified in the operation manual. An incorrect voltage may result in malfunction or burning.
- Take appropriate measures to ensure that the specified power with the rated voltage and frequency is supplied. Be particularly careful in places where the power supply is unstable. An incorrect power supply may result in malfunction.
- Do not apply voltages to the Input Units in excess of the rated input voltage. Excess voltages may result in burning.
- Do not apply voltages or connect loads to the Output Units in excess of the maximum switching capacity. Excess voltage or loads may result in burning.
- Check the user program for proper execution before actually running it on the Unit. Not checking the program may result in unexpected operation.
- Always turn OFF the power supply to the PLC before attempting any of the following. Not turning OFF the power supply may result in malfunction or electric shock.
 - Mounting or dismounting Power Supply Units, I/O Units, CPU Units, Memory Cassettes, Master Units, or any other Units.
 - Removing or attaching terminal blocks to Remote I/O Terminals.
 - Assembling Racks.
 - Setting DIP switches or rotary switches.
 - Connecting cables or wiring the system.
 - Connecting or disconnecting the connectors.
- Before touching a Unit, be sure to first touch a grounded metallic object in order to discharge any static build-up. Not doing so may result in malfunction or damage.
- Confirm that no adverse effect will occur in the system before attempting any of the following. Not doing so may result in unexpected operation.
 - Changing the operating mode of the PLC.
 - Force-setting/force-resetting any bit in memory.
 - Changing the present value of any word or any set value in memory.
- When replacing parts, be sure to confirm that the rating of a new part is correct. Not doing so may result in malfunction or burning.
- After replacing Units, resume operation only after transferring to the new CPU Unit and/or Special I/O Units the contents of the DM Area, HR Area, and other data required for resuming operation. Not doing so may result in unexpected operation.
- When transporting the Unit, use special packing boxes and protect it from being exposed to excessive vibration or impact during transportation.

- Use only the specified communications cables.
- Do not extend connection distances beyond the ranges given in the specifications.
- Observe the following precautions when wiring the communications cable.
 - Separate the communications cables from the power lines or high-tension lines.
 - Do not bend the communications cables past their natural bending radius.
 - Do not pull on the communications cables.
 - Do not place heavy objects on top of the communications cables.
 - Always lay communications cable inside ducts.

6 Conformance to EC Directives

6-1 Applicable Directives

- EMC Directives
- Low Voltage Directive

6-2 Concepts

EMC Directives

OMRON devices are designed so that they comply with the related EMC Directives so that they can be more easily built into other devices or the overall machine. The actual products have been checked for conformity to EMC Directives (see the following note). Whether the products conform to the standards in the system used by the customer, however, must be checked by the customer.

EMC-related performance of the OMRON devices that comply with EC Directives will vary depending on the configuration, wiring, and other conditions of the equipment or control panel on which the OMRON devices are installed. The customer must, therefore, perform the final check to confirm that devices and the overall machine conform to EMC standards.

Note Applicable EMC (Electromagnetic Compatibility) standards are as follows:

EMS (Electromagnetic Susceptibility): EN 61000-6-2

EMI (Electromagnetic Interference): EN 61000-6-4

(Radiated emission: 10-m regulations)

Low Voltage Directive

Always ensure that devices operating at voltages of 50 to 1,000 V AC and 75 to 1,500 V DC meet the required safety standards for EN 61131-2.

6-3 Conformance to EC Directives

The CompoNet Master Units comply with EC Directives. To ensure that the machine or device in which a CompoNet Master Unit is used complies with EC Directives, the CompoNet Master Unit must be installed as follows:

- 1,2,3...**
1. The CompoNet Master Unit must be installed within a control panel.
 2. You must use reinforced insulation or double insulation for the DC power supplies used for the communications power supply and I/O power supplies.

3. CompoNet Master Units complying with EC Directives also comply with the Common Emission Standard (EN 61000-6-4). Radiated emission characteristics (10-m regulations) may vary depending on the configuration of the control panel used, other devices connected to the control panel, wiring, and other conditions. You must therefore confirm that the overall machine or equipment complies with EC Directives.

SECTION 1

Overview

This section provides an overview of CompoNet Networks.

1-1	CompoNet Networks	2
1-1-1	Overview	2
1-1-2	Overall System Configuration and Elements	2
1-1-3	System Configuration Patterns	4
1-1-4	Features of CompoNet Networks	5
1-2	CompoNet Network Specifications	7
1-2-1	Cable Types, Baud Rates, and Maximum Distances	9
1-2-2	Branch Line Support for Cable Types and Baud Rates	11
1-2-3	Allocating Slave Units in the CPU Unit Memory Area by Communications Mode Number	12
1-3	Devices in a CompoNet Network	14
1-3-1	Master Units and Slave Units	14
1-3-2	Peripheral Devices	18
1-3-3	Selecting Peripheral Devices Used According to Connection Configuration	24
1-3-4	CompoNet Slave Unit Functions	25
1-4	Overview of Design Flow	26
1-5	Overview of Operating Procedure	27
1-6	Design and Operating Procedure Examples	28
1-6-1	Design	28
1-6-2	Operating Procedure	34

1-1 CompoNet Networks

1-1-1 Overview

CompoNet Networks feature easy operation and installation in a component-level network connecting PLCs and on-site I/O.

The PLC and CompoNet Slave Units cyclically exchange I/O information through a CompoNet Master Unit, refreshing I/O in sync with the PLC scan.

Message communications can also be used from host computers or the CPU Unit of the PLC to read and write CompoNet Slave Unit data.

1-1-2 Overall System Configuration and Elements

A CompoNet Network is a remote I/O system that consists of the following elements.

System Configuration Example

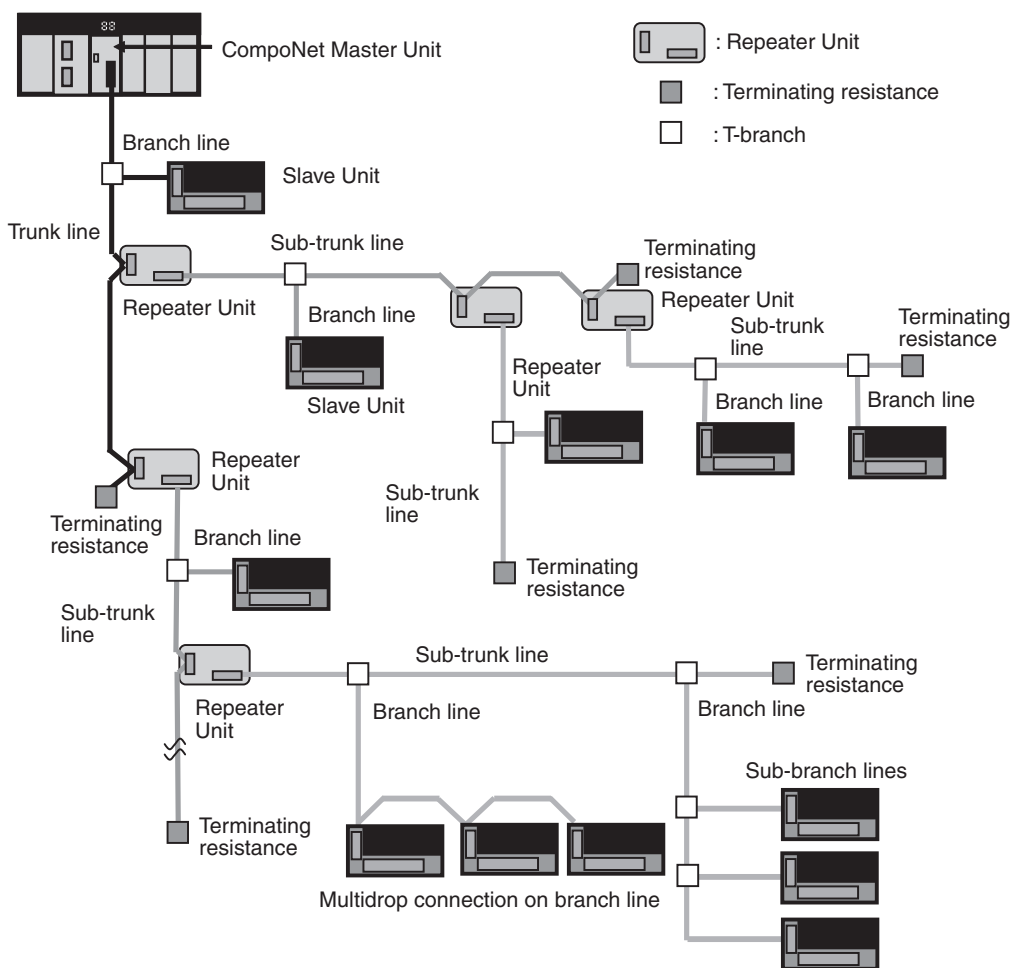

Communications Cables

CompoNet Networks use VCTF 2-conductor cables, Standard Flat Cables (DCA4-4F10), and Sheathed Flat Cables (DCA5-4F10) for communications cables.

- Master Unit** The CompoNet Master Unit manages the network and transfers I/O data between the PLC and the Slave Units.
- There is only one Master Unit per network. The Master Unit must be connected to the trunk line.
- Slave Units** Some Slave Units receive output data from the Master Unit across the network and output it.
- Other Slave Units send data that has been input across the network to the Master Unit.
- There are two types of Slave Unit depending on the I/O capacity of the Slave Unit.
- **Word Slave Units:** Word Slave Units are allocated units of 16 bits (i.e., 16 I/O points).
 - **Bit Slave Units:** Bit Slave Units are allocated units of 2 bits (i.e., 2 I/O points).
- There are also two types of Bit Slave Unit depending on their environment resistance: IP20 Slave Units and IP54 Slave Units. There are also two types of Flat Cable according to the environment resistance: Standard Flat Cable and Sheathed Flat Cable.
- Repeater Unit** Using Repeater Units enables expanding network connections as follows:
- Extending the cable length
 - Increasing the number of nodes
 - Creating long-distance T-branches from the trunk line and sub-trunk lines (See note.)
 - Converting between different types of cable (VCTF 2-conductor cable, Standard Flat Cable, and Sheathed Flat Cable)
- A sub-trunk line downstream from a Repeater Unit can be connected with the same communications specifications (i.e., distances and number of Slave Units) as the trunk line.
- Up to 64 Repeater Units can be connected per network (i.e., per Master Unit). When Repeater Units are connected in series from the Master Unit, up to two extra segment layers can be created (i.e., up to 2 Repeater Units are allowed between a Slave Unit and the Master Unit).
- Note** The physical layer is not connected across a Repeater Unit. The connection is thus different from a branch connection, which branches the same physical layer.
- Terminating Resistance** With a CompoNet Network, the Master Unit is located at one end of the trunk line and terminating resistance is connected to the other end of the trunk line.
- If Repeater Units are used, each Repeater Unit is treated like a Master Unit, i.e., terminating resistance is connected to the most remote end of the sub-trunk line downstream from the Repeater Unit.
- Note** Terminating resistance reduces signal bouncing to stabilize communications and must always be connected to the most remote ends of the network lines below the Master Unit and each Repeater Unit. Always connect terminating resistance to ensure the quality of the transmission path.

Trunk Lines and Branch Lines

The trunk lines and branch lines are defined as follows:

- Trunk line: The transmission path between the Master Unit and the terminating resistance.
- Sub-trunk line: The transmission path between the Repeater Unit and the terminating resistance.
- Branch line: The transmission path created using a T-branch from the trunk line or sub-trunk line.
- Sub-branch line: The transmission path created using a T-branch from a branch line. (T-branching is not possible from sub-branch lines.)

Note Due to differences in functionality, the same type of cable must be used between the trunk line and a branch line, a sub-trunk line and branch line, and a branch line and sub-branch line. Different types of cable can be used between the trunk line and a sub-trunk line.

Branches

There are two ways to create branch lines.

1) Multidrop Connections

- Multidrop connections using pressure-welded multi-drop connectors
- Multidrop connections using Terminal Block Adapters

2) T-branch Connections

- T-branch connections using commercially available relay terminal blocks
- T-branch connections using pressure-welded connectors

Note Pressure-welded connectors can also be used to extend the cable length.

Communications Power Supply

A commercially available 24-VDC power supply is used to power communications.

One communications power supply can be connected for each trunk line and sub-trunk line. Communications power is supplied to the trunk line from the Master Unit and to a sub-trunk line from the Repeater Unit.

One power supply cannot be used to supply communications power to more than one line (i.e., to the trunk line and sub-trunk line or to two sub-trunk lines).

1-1-3 System Configuration Patterns

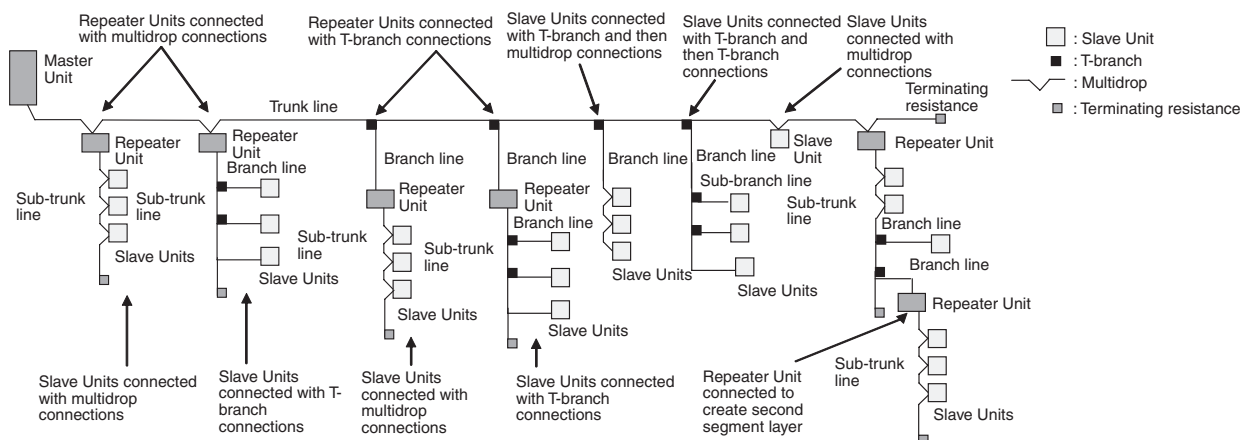

1-1-4 Features of CompoNet Networks

Programless Communications

Cyclic data exchange using remote I/O communications can be achieved between a Master Unit mounted on a PLC and multiple Slave Units using only VCTF 2-conductor cable or Flat Cable (standard or sheathed).

High-speed Multi-point Processing

Remote I/O communications for up to 2,560 I/O points can be achieved at approximately 1,000 points per millisecond (at 4 Mbits/s, see note). This enables configuring CompoNet Network systems to replace systems previously configured with Basic I/O Units.

Note Branch lines cannot be used at 4 Mbits/s. Slave Units with Cables (i.e., Bit Slave Units) can thus not be used.

Easy Introduction

Remote I/O communications can be started merely by connecting the Master Unit and Slave Units with communications cables, setting the switches on the Master Unit, and turning ON the power to the Slave Units and PLC.

Repeater Units for Greater Flexibility

Repeater Units can be used in a network to enable the following network expansions.

- Extending the cable length
- Increasing the number of nodes
- Branching from the trunk line
- Changing the type of cable

Repeater Units can be used to extend up to two segment layers (called sub-trunk lines) from the trunk line. Up to 64 Repeater Units can be connected per Master Unit and up to 32 Repeater Units can be connected to the trunk line.

Note Communications power is supplied to a sub-trunk line from the Repeater Unit.

Bit-level Distribution

Slave Units with industry-standard e-CON connectors or clamping terminal blocks can be used to distribute I/O at the bit level. This enables distributed control in distributed devices, such as sensors and other devices located over a wide area on conveyors or in warehouses.

Bit Slave Units are available in two types: IP20 and IP54.

Five Communications Modes According to Number of Nodes, I/O Points, and Allocated Memory

There are five communications modes that can be used according to number of Slave Units, the number of I/O points, and the location of allocated memory. Memory can be allocated to Slave Units in the Special I/O Unit portion of the CIO Area or, if the CompoNet Support Software software settings are used, in any part of the CIO, DM, WR, and HR Areas.

This enables efficient application of memory according to the size of the system.

Data Exchange with Message Communications

Message communications can be used from the CompoNet Support Software running on a host computer or from the CPU Unit of the PLC to access Slave Units and Repeater Units on the CompoNet Network. This enables easily improving network and system maintenance.

Easy Maintenance with Complete System Monitoring Functions

The CompoNet Network is constantly monitored to enable confirming system safety by quickly isolating errors and checking communications status.

■ CompoNet Support Software

The CompoNet Support Software provides the following network functionality.

- Uploading the network configuration
- Editing and transferring software setting tables

- Editing and transferring registration tables
- Setting Input Data Zero Clear Mode for when communications error occur
- Setting I/O Communications Manual Startup Mode
- Monitoring Master Unit status
- Monitoring the Master Unit error history
- Monitoring Slave Unit network participation status
- Setting and transferring Slave Unit parameters
- Monitoring Slave Unit information
- Managing files
- Managing hardware (EDS files)

■ Smart Slave Unit Functions

The Slave Units provide Smart Functions that can record various added-value information in addition to the ON/OFF signals (I/O data). This enables preventive system maintenance (including operation time monitoring and contact operation counter monitoring) and aids in faster system introduction (including communications power voltage monitoring and I/O power status monitoring). Settings are possible from either the CompoNet Support Software or through message communications.

■ Master Unit Detection of Network Participation, Errors, and Status

When a Slave Unit joins the network, a bit corresponding to the node address called a Participation Flag will turn ON. If a Slave Unit that has been participating in the network leaves the network, a bit corresponding to the node address called an Error Flag will turn ON.

Network status, such as communications errors and redundant Slave Unit node address, and Slave Unit diagnostic results are detected by the Master Unit and display on the seven-segment display on the front panel and reflected in the Status Flags.

■ Registration Tables

Tables of the Slave Unit that should be participating at each node (i.e., the node address and corresponding Slave Unit model number) can be registered from the CompoNet Support Software to verify the Slave Units actually participating in the network and prevent unregistered Slave Units from participating in the network. A monitoring time for registered Slave Unit participation after power is turned ON can also be set.

Remote I/O communications can be stopped until all registered Slave Units are participating and remote I/O communications can be started as soon as all registered Slave Units are participating (called Registered Slave Unit Participation Standby Mode).

■ Stopping Communications at Communications Errors

A DIP switch on the front of the Master Unit can be set to stop remote I/O communications when a communications error has occurred in any of the Slave Units.

■ I/O Communications Manual Startup Mode

I/O Communications Manual Startup Mode can be set from the CompoNet Support Software so that remote I/O communications are not started when the power is turned ON. Remote I/O communications will not start until the Remote I/O Communications Start Switch is turned ON in memory.

■ Communications Error Input Data Zero Clear Mode

Input Data Zero Clear Mode can be set from the CompoNet Support Software for communications error. If a communications error occurs for a Slave Unit in this mode, all input data for that Slave Unit will be cleared to zeros. This can be used to suppress triggering operations when communications errors have occurred in systems where ON input data signals are used as triggers for operation.

■ Communications Status on Master Unit Seven-segment Display

The seven-segment display on the front of the Master Unit can be used to check communications status.

The baud rate is normally displayed, but if an error occurs, the error code is displayed in hexadecimal and the error node address is displayed in decimal.

Automatic Baud Rate Detection

The Slave Units will automatically detect and use the baud rate set on the DIP switch on the Master Unit. Setting the baud rate is not necessary for any of the Slave Units.

1-2 CompoNet Network Specifications

Item	Specifications
Communications method	CompoNet protocol
Types of communications	Remote I/O communications (programless, constant sharing of data with Slave Units) and message communications (explicit message communications as required with Slave Units and FINS message communications as required with PLCs)
Baud rate	4 Mbits/s (See note)., 3 Mbits/s, 1.5 Mbits/s, 93.75 kbits/s Note A baud rate of 4 Mbits/s is not supported for branch lines and thus cannot be used for Slave Units with Cables (i.e., Bit Slave Units).
Modulation	Base-band
Coding	Manchester code
Error control	Manchester code rules, CRC
Communications media	The following media can be used. <ul style="list-style-type: none"> • VCTF 2-conductor cable (JIS C 3306, 2-conductor) • Standard Flat Cable (DCA4-4F10) • Sheathed Flat Cable (DCA5-4F10) Note VCTF 2-conductor cable, Standard Flat Cable, and Sheathed Flat Cable are all different types of cable. To use more than one type of cable, they must be separated on the trunk line and a sub-trunk line or on different sub-trunk lines.
Communications distance and wiring	Refer to <i>1-2-1 Cable Types, Baud Rates, and Maximum Distances</i> .
Connectable Master Units	CompoNet Master Units
Connectable Slave Units	CompoNet Slave Units
Maximum I/O capacity	Word Slave Units: 1,024 inputs and 1,024 outputs (2,048 I/O points total) Bit Slave Units: 256 inputs and 256 outputs (512 I/O points total)
Maximum number of nodes	Word Slave Units: 64 input nodes and 64 output nodes Bit Slave Units: 128 input nodes and 128 output nodes
Bits allocated per node address	Word Slave Units: 16 bits Bit Slave Units: 2 bits
Maximum number of nodes without Repeater Units (One trunk line or sub-trunk line)	32 nodes
Applicable node addresses	Word Slave Units: IN0 to IN63 and OUT0 to OUT63 Bit Slave Units: BIT IN0 to BIT IN127 and BIT OUT0 to BIT OUT127 Repeater Units: 0 to 63

Item	Specifications
Repeater Unit application conditions	Up to 64 Repeater Units can be connected per network (i.e., per Master Unit). Up to 32 Repeater Units can be connected per trunk line or per sub-trunk line. When Repeater Units are connected in series from the Master Unit, up to two extra segment layers can be created (i.e., up to 2 Repeater Units are allowed between a Slave Unit and the Master Unit).
Signal lines	Two lines: BDH (communications data high) and BDL (communications data low)
Power lines	Two lines: BS+ and BS- (power for communications and internal Slave Unit circuits) • Power is supplied from the Master Unit and Repeater Units.
Communications power supply voltage	24 VDC \pm 10%
Connection forms	Standard or Sheathed Flat Cable at baud rate of 93.75 kbits/s: No restrictions Other cables or baud rates: Trunk line and branch lines Connections for Slave Units and Repeater Units: T-branch or multidrop connections
Remote I/O communications	Automatic startup when power is turned ON (See note.) or manual startup using the Remote I/O Communications Start Switch in I/O Communications Manual Start Mode Note When power is turned ON to the PLC and the Slave Unit communications power is turned ON. Communications are not started in the following cases: • In Registered Slave Unit Participation Standby Mode, communications is not started until all registered Slave Units are participating in the network. • In Communications Error Communications Stop Mode, communications stop when a communications error occurs.
I/O Communications Manual Startup Mode	I/O Communications Manual Startup Mode can be set from the CompoNet Support Software so that remote I/O communications are not started when the power is turned ON. Remote I/O communications will not start until the Remote I/O Communications Start Switch is turned ON in memory.
Communications Error Communications Stop Mode	All remote I/O communications are stopped if a communications error occurs in any Slave Unit. Note Communications will not stop for verification errors for registration tables or duplicated address settings.
Communications Error Input Data Zero Clear Mode	All input data will be cleared to zeros in any Slave Unit in which a communications error occurs.
Duplicated Slave Unit address check	If the same address is set for two different Slave Units or the same memory is allocated to two different nodes, the Slave Unit that joins communications last will cause a duplicated address error and will leave the network. The Duplicated Address Error Flag will turn ON. Note This error will also occur if a Slave Unit leaves the network and then a different type of Slave Unit joins the network.
Registration Tables	The Slave Units that can participate for each node address are registered in a table so that only the registered Slave Units can participate. If a different Slave Unit attempts to join the network, the Registration Table Verification Error Flag will turn ON. The Registration Table is generated automatically or manually edited from the CompoNet Support Software.

Item		Specifications
Slave Unit status	Without Registration Table	Participation Flag and Communications Error Flag for each Slave Unit <ul style="list-style-type: none"> Participation Flag: Turns ON and remains ON if the Slave Unit joins the network even one time after system power is turned ON. Communications Error Flag: Turns ON if the Slave Unit cannot communicate with the Master Unit for any reason after the Slave Unit has joined the network (i.e., if the Participation Flag is ON). (Turns OFF when the error is removed.) Duplicated Address Error Flags and Alarm Flags
	With Registration Table	<ul style="list-style-type: none"> Participation Flags and Communications Error Flags for each node address for all Slave Units registered in the Registration Table Registration Table Verification Error Flags All Registered Slave Units Participating Flag <p>Note The Registered Slave Unit Participation Monitoring Time can be set (verification error check timing). Registered Slave Unit Participation Standby Mode can be set. (Remote I/O communications will not start until all registered Slave Units are participating.)</p>

1-2-1 Cable Types, Baud Rates, and Maximum Distances

This section provides specification on the maximum cable length and maximum number of nodes for each type of cable. Do not exceed these specifications.

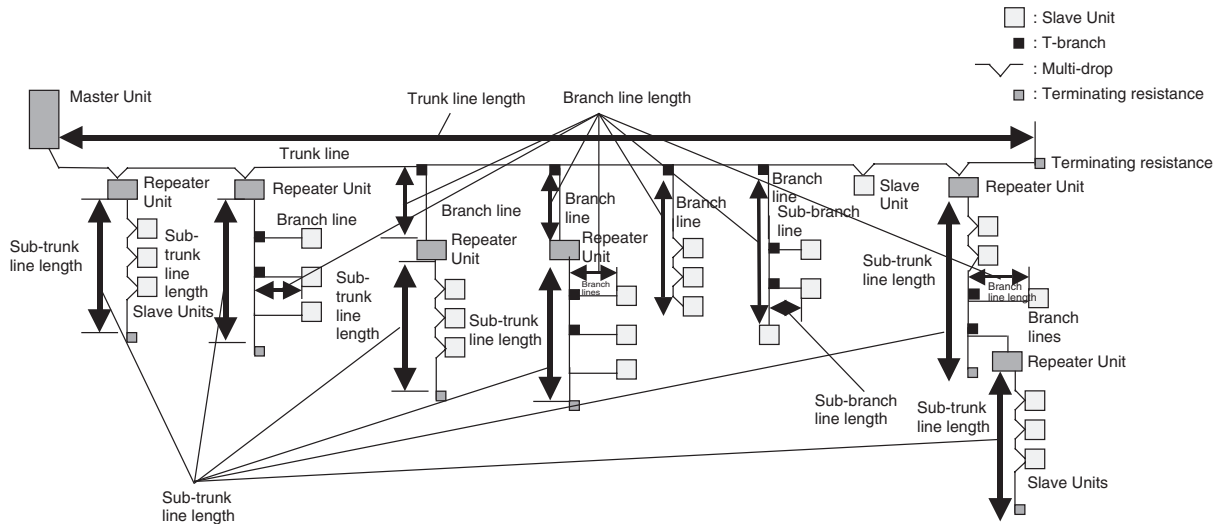

■ Baud Rate of 4 Mbits/s (No Branch Lines, See Note 2)

Cable	Length per trunk line or sub-trunk line (maximum length with two Repeater Units)	Branch line length	Total branch line length	Branch restrictions	Maximum number of Slave Units (Slave Units per trunk line)
VCTF 2-conductor	30 m (90 m)	NA (See note 1.)	NA (See note 1.)	---	32 nodes
Standard or Sheathed Flat Cable	30 m (90 m)	NA (See note 1.)	NA (See note 1.)	---	32 nodes

- Note**
- (1) Lines cannot be branched from the trunk line. (Only multidrop connections are possible from the trunk line or sub-trunk lines.)
 - (2) Bit Slave Units come with special cables and cannot be connected. The network must consist of only Word Slave Units (use DCN4-MD4 Multi-drop Connectors for the Flat Cable) and multidrop connections must be used.

■ Baud Rate of 3 Mbits/s

Cable	Length per trunk line or sub-trunk line (maximum length with two Repeater Units)	Branch line length	Total branch line length	Branch restrictions	Maximum number of nodes per branch (See note.)	Sub-branch line length	Total sub-branch line length	Maximum number of Slave Units (Slave Units per trunk line)
VCTF 2-conductor	30 m (90 m)	0.5 m	8 m	3 branches/m	1 node	NA	NA	32 nodes
Standard or Sheathed Flat Cable	30 m (90 m)	0.5 m	8 m	3 branches/m	1 node	NA	NA	32 nodes

Note The maximum number of nodes per branch is the maximum number of Slave Units or Repeater Units that can be connected to one branch line using multidrop or T-branch connections.

■ Baud Rate of 1.5 Mbits/s

Cable	Length per trunk line or sub-trunk line (maximum length with two Repeater Units)	Branch line length	Total branch line length	Branch restrictions	Maximum number of nodes per branch (See note 3.)	Sub-branch line length	Total sub-branch line length	Maximum number of Slave Units (Slave Units per trunk line)
VCTF 2-conductor	With-out branch lines	100 m (300 m)	NA (See note 1.)	NA (See note 1.)	---	---	---	32 nodes
	With branch lines	30 m (90 m)	2.5 m	25 m	3 branches/m	3 nodes	NA	NA
Standard or Sheathed Flat Cable	30 m (90 m)	2.5 m	25 m	3 branches/m	3 nodes	0.1 m (See note 2.)	2 m (See note 2.)	32 nodes

Note

- (1) Lines cannot be branched from the trunk line. (Only multidrop connections are possible from the trunk line or sub-trunk lines.)
- (2) Lines can be branched from sub-branch lines.
- (3) The maximum number of nodes per branch is the maximum number of Slave Units or Repeater Units that can be connected to one branch line using multidrop or T-branch connections.

■ Baud Rate of 93.75 kbits/s

Cable	Length per trunk line or sub-trunk line (maximum length with two Repeater Units)	Branch line length	Total branch line length	Branch restrictions	Maximum number of nodes per branch (See note 2.)	Sub-branch line length	Total sub-branch line length	Maximum number of Slave Units (Slave Units per trunk line)
VCTF 2-conductor	500 m (1,500 m)	6 m	120 m	NA	NA	---	---	32 nodes
Standard or Sheathed Flat Cable	No restrictions to a total network length of 200 m							32 nodes

- Note**
- (1) Lines cannot be branched from the trunk line. (Only multidrop connections are possible from the trunk line or sub-trunk lines.)
 - (2) The maximum number of nodes per branch is the maximum number of Slave Units or Repeater Units that can be connected to one branch line using multidrop or T-branch connections.

1-2-2 Branch Line Support for Cable Types and Baud Rates

Support for branch lines from the trunk line or sub-trunk lines and support for sub-branch lines from branch lines is listed in the following tables.

■ Baud Rate of 4 Mbits/s (No Branch Lines)

Cable	Branch lines	Sub-branch lines
VCTF 2-conductor	NA	NA
Standard or Sheathed Flat Cable	NA	NA

Note A baud rate of 4 Mbit/s is not supported for branch lines and thus cannot be used for Slave Units with Cables (i.e., Bit Slave Units). The network must consist of only Word Slave Units (use DCN4-MD4 Multidrop Connectors for the Flat Cable) and multidrop connections must be used.

■ **Baud Rate of 3 Mbits/s**

Cable		Branch lines	Sub-branch lines
VCTF 2-conductor		Supported	NA
Standard or Sheathed Flat Cable		Supported	NA

■ **Baud Rate of 1.5 Mbits/s**

Cable		Branch lines	Sub-branch lines
VCTF 2-conductor	100 m max.	NA	NA
	30 m max.	Supported	
Standard or Sheathed Flat Cable		Supported	Supported

■ **Baud Rate of 93.75 kbits/s**

Cable		Branch lines	Sub-branch lines
VCTF 2-conductor		Supported	NA
Standard or Sheathed Flat Cable		Supported (no restrictions)	

1-2-3 **Allocating Slave Units in the CPU Unit Memory Area by Communications Mode Number**

Slave Unit I/O information and status information is allocated in the Special I/O Unit memory area or a user-specified area of the CPU Unit to which the Master Unit is mounted.

The area is determined by the unit number of the Master Unit as a Special I/O Unit and by the communications mode number. The user specifies the communications mode number using the CompoNet Support Software. The bits used by Slave Units are determined by the node address for each Slave Unit.

The relationship between communications mode numbers, the number of connected nodes, and the number of points that can be controlled is described next.

Number of Connected Nodes and Control Points Per Master Unit

Use the rotary switch on the front of the Master Unit to select the communications mode number.

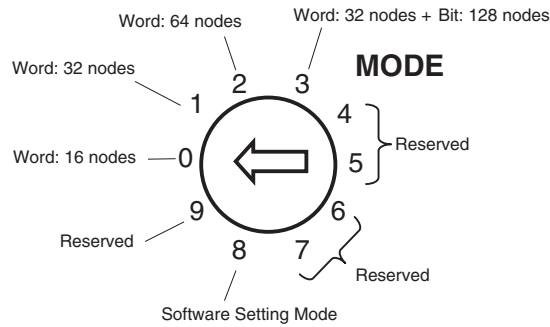

Communications mode number	Mode name	Connectable node addresses	Control points	Memory area	Number of unit numbers used by each Master Unit
0	Mode 0	Word Slave Units: IN0 to IN7 and OUT0 to OUT7	128 inputs and 128 outputs (Word Slave Units)	Special I/O Unit Area (First word depends on unit number of Master Unit.)	2
1	Mode 1	Word Slave Units: IN0 to IN15 and OUT0 to OUT15	256 inputs and 256 outputs (Word Slave Units)		4
2	Mode 2	Word Slave Units: IN0 to IN31 and OUT0 to OUT31	512 inputs and 512 outputs (Word Slave Units)		8
3	Mode 3	Word Slave Units: IN0 to IN15 and OUT0 to OUT15 Bit Slave Units: IN0 to IN63 and OUT0 to OUT63	256 inputs and 256 outputs (Word Slave Units) 128 inputs and 128 outputs (Word Slave Units)		8
4	Reserved	---	---	---	---
5	Reserved	---	---	---	---
6	Reserved	---	---	---	---
7	Reserved	---	---	---	---
8	Software Setting Mode	Can be set within the following ranges: Word Slave Units: IN0 to IN63 and OUT0 to OUT63 Bit Slave Units: IN0 to IN127 and OUT0 to OUT127	Can be set within the following ranges: Word Slave Units: 1,024 inputs and 1,024 outputs Bit Slave Units: 256 inputs and 256 outputs	Can be allocated anywhere in the CIO, DM, WR, or HR Area. Note Status and parameters are allocated in the Special I/O Unit Area.	1
9	Reserved	---	---	---	---

- Note**
- (1) In a CompoNet Network, Word Slave Units have 16 bits per node address. Bit Slave Units have two bits allocated per node address.
 - (2) Do not use the reserved communications mode numbers (4 to 7 and 9). A communications mode setting error (H4 at the 7-segment LED indicator) will occur if any of these mode numbers is set.

1-3 Devices in a CompoNet Network

1-3-1 Master Units and Slave Units

CompoNet Master Units

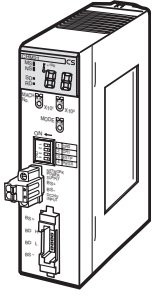
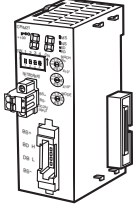
Name	Model	Unit classification	Maximum number per CPU Unit			Communications Cables (Yes: Can be used. No: Cannot be used.)		
						VCTF 2-conductor cable	Standard Flat Cable	Sheathed Flat Cable
	CS1W-CRM21	CS-series Special I/O Unit	Communications mode No.			Yes (See note 1.)	Yes (See note 2.)	Yes (See note 3.)
			8 (1 unit number used)	80				
			0 (2 unit numbers used)	48				
			1 (4 unit numbers used)	24				
			2 or 3 (8 unit numbers used)	12				
	CJ1W-CRM21	CJ-series Special	Communications mode No.	CJ1-H/ CJ1 CPU Units	CJ1M CPU Units	Yes (See note 1.)	Yes (See note 2.)	Yes (See note 3.)
			8 (1 unit number used)	40	20			
			0 (2 unit numbers used)	40	20			
			1 (4 unit numbers used)	24	20			
			2 or 3 (8 unit numbers used)	12	12			

- Note**
- (1) A DCN4-TB4 Terminal Block Adapter is required when VCTF 2-conductor cable is used.
 - (2) A DCN4-TR4 Trunk Line Pressure-welded Connector is required when Standard Flat Cable is used.
 - (3) A DCN5-TR4 Trunk Line Pressure-welded Connector is required when Sheathed Flat Cable is used.

CompoNet Slave Units

There are several types of Slave Units for a CompoNet Network, as shown below. Select the Slave Units according to the application.

The following table provides the names and descriptions of the various Slave Units.

- Word Slave Units: Slave Units that are allocated units of 16 bits (words) in I/O memory of the CPU Unit.
 - Digital I/O Slave Units: Slave Units that provide eight or more digital contact I/O points
One Expansion Digital I/O Slave Unit can be mounted.
 - Analog I/O Slave Units: Slave Units with I/O functions for analog values.

- Bit Slave Units: Slave Units that are allocated units of 2 bits in I/O memory at the CPU Unit.
A Bit Slave Unit provides 2 or 4 digital contact I/O points. Bit Slave Units come in models with either IP20 or IP54 protection.

Word Slave Units

Use Flat Cable (either Standard or Sheathed) or VCTF 2-conductor cable.

■ **Digital I/O Slave Units**

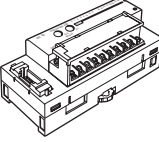
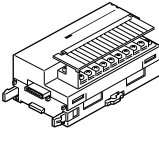
Name	Appearance	Model	Specifications	Communications Cables (Yes: Can be used. No: Cannot be used.)		
				VCTF 2-conductor cable	Standard Flat Cable	Sheathed Flat Cable
Basic Units		CRT1-ID16	16 DC inputs (NPN)	Yes (See note 1.)	Yes (See note 2.)	Yes (See note 3.)
		CRT1-ID16-1	16 DC inputs (PNP)			
		CRT1-OD16	16 transistor outputs (NPN)			
		CRT1-OD16-1	16 transistor outputs (PNP)			
Expansion Units		XWT-ID08	8 DC inputs (NPN)	One Expansion Unit can be mounted per Basic Unit.		
		XWT-ID08-1	8 DC inputs (PNP)	One Expansion Unit can be mounted per Basic Unit.		
		XWT-OD08	8 transistor outputs (NPN)	One Expansion Unit can be mounted per Basic Unit.		
		XWT-OD08-1	8 transistor outputs (PNP)	One Expansion Unit can be mounted per Basic Unit.		
		XWT-ID16	16 DC inputs (NPN)	One Expansion Unit can be mounted per Basic Unit.		
		XWT-ID16-1	16 DC inputs (PNP)	One Expansion Unit can be mounted per Basic Unit.		
		XWT-OD16	16 transistor outputs (NPN)	One Expansion Unit can be mounted per Basic Unit.		
		XWT-OD16-1	16 transistor outputs (PNP)	One Expansion Unit can be mounted per Basic Unit.		

- Note**
- (1) A DCN4-TB4 Terminal Block Adapter is required when VCTF 2-conductor cable is used.
 - (2) A DCN4-TR4 Trunk Line Pressure-welded Connector is required when Standard Flat Cable is used.
 - (3) A DCN5-TR4 Trunk Line Pressure-welded Connector is required when Sheathed Flat Cable is used.

■ **Analog I/O Slave Units**

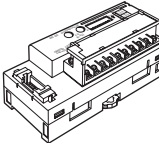
Name	Appearance	Model	Specifications	Communications Cables (Yes: Can be used. No: Cannot be used.)		
				VCTF 2-conductor cable	Standard Flat Cable	Sheathed Flat Cable
Analog I/O Slave Units		CRT1-AD04	4 analog inputs	Yes (See note 1.)	Yes (See note 2.)	Yes (See note 3.)
		CRT1-DA02	2 analog outputs			

- Note**
- (1) A DCN4-TB4 Terminal Block Adapter is required when VCTF 2-conductor cable is used.
 - (2) A DCN4-TR4 Trunk Line Pressure-welded Connector is required when Standard Flat Cable is used.
 - (3) A DCN5-TR4 Trunk Line Pressure-welded Connector is required when Sheathed Flat Cable is used.

Bit Slave Units

■ IP20 Bit Slave Units

IP20 Bit Slave Units come with 50 cm of Standard Flat Cable already connected. (Branch Pressure-welded Connectors are sold separately.)

Note A baud rate of 4 Mbits/s cannot be used Bit Slave Units.

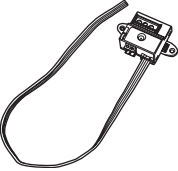
Name	Appearance	Model	Specifications		Communications Cables (Yes: Can be used. No: Cannot be used.)		
					VCTF 2-conductor cable	Standard Flat Cable	Sheathed Flat Cable
IP20 Bit Slave Units		CRT1B-ID02S	2 DC inputs, industrial standard connector (e-CON) (NPN)	Provided with Standard Flat Cable.	No	Yes (See note.)	No
		CRT1B-ID02S-1	2 DC inputs, industrial standard connector (e-CON) (PNP)				
		CRT1B-OD02S	2 transistor outputs, industrial standard connector (e-CON) (NPN)				
		CRT1B-OD02S-1	2 transistor outputs, industrial standard connector (e-CON) (PNP)				

Note A DCN4-TR4 Trunk Line Pressure-welded Connector is required when Standard Flat Cable is used.

■ IP54 Bit Slave Units

IP54 Bit Slave Units come with 50 cm of Sheathed Flat Cable already connected. (Branch Pressure-welded Connectors are sold separately.)

Name	Appearance	Model	Specifications	Communications Cables (Yes: Can be used. No: Cannot be used.)			
				VCTF 2-conductor cable	Standard Flat Cable	Sheathed Flat Cable	
IP54 Bit Slave Units		CRT1B-ID02SP	2 DC inputs, industrial standard connector (e-CON) (NPN)	IP54 Units are provided with Sheathed Flat Cable.	No	No	Yes (See note.)
		CRT1B-ID02SP-1	2 DC inputs, industrial standard connector (e-CON) (PNP)				
		CRT1B-ID04SP	4 DC inputs, industrial standard connector (e-CON) (NPN)				
		CRT1B-ID04SP-1	4 DC inputs, industrial standard connector (e-CON) (PNP)				
		CRT1B-OD02SP	2 transistor outputs, industrial standard connector (e-CON) (NPN)				
		CRT1B-OD02SP-1	2 transistor outputs, industrial standard connector (e-CON) (PNP)				
		CRT1B-MD04SLP	2 DC inputs/2 transistor inputs/outputs, clamp terminal block (NPN)				
		CRT1B-MD04SLP-1	2 DC inputs/2 transistor inputs/outputs, clamp terminal block (PNP)				

Note A DCN5-TR4 Trunk Line Pressure-welded Connector is required when Sheathed Flat Cable is used.

CompoNet Repeater Unit

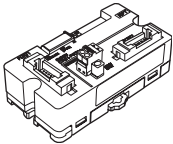
Name	Appearance	Model	Specifications	Communications Cables (Yes: Can be used. No: Cannot be used.)		
				VCTF 2-conductor cable	Standard Flat Cable	Sheathed Flat Cable
Repeater Unit		CRS1-RPT01	<p>A sub-trunk line can be connected downstream (for trunk-branch line form) or further branching is enabled downstream (for wiring with no restrictions) in the same way as for a Master Unit.</p> <p>A Repeater Unit can be used to branch the trunk line and increasing the number of connected Units, as well as to extend the length of the communications line.</p>	Yes	Yes	Yes

1-3-2 Peripheral Devices

Communications Cables

The following table shows the Communications Cables that can be used in a CompoNet Network.

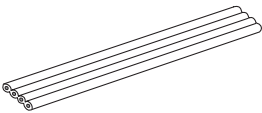
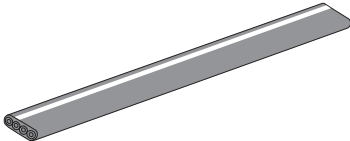
Name		Model	Specifications	Remarks
VCTF 2-conductor cable		---	<p>JIS C 3306</p> <p>Nominal cross-sectional area: 0.75 mm²,</p> <p>Finished conductor diameter: 2.3 mm</p>	Cannot be used with Bit Slave Units.
Flat Cable	Standard	DCA4-4F10	<p>4-conductor flat cable (UL2555)</p> <p>Length: 100 m</p> <p>Conductor diameters: 0.75 mm² × 2, 0.5 mm² × 2</p>	Approximately 50 cm of cable comes connected to IP20 Bit Slave Units.
		Sheathed	DCA5-4F10	<p>Sheathed 4-conductor flat cable</p> <p>Length: 100 m</p> <p>Conductor diameters: 0.75 mm² × 2, 0.5 mm² × 2</p>
				

Connectors

In a CompoNet Network, the connectors described below can be connected to the Communications Cable to enable extending the cable length, branching cables, and wiring to Slave Units.

Trunk Line Pressure-welded Connectors

■ For Standard Flat Cable

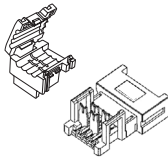
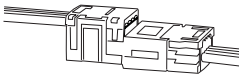
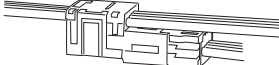
Name	Model	Appearance	Application	Communications Cables (Yes: Can be used. No: Cannot be used.)		
				VCTF 2-conductor cable	Standard Flat Cable	Sheathed Flat Cable
Standard Flat Cable Trunk Line Pressure-welded Connector	DCN4-TR4		<p>Use this Connector in a set with a DCN4-BR4 Standard Flat Cable Branch Line Pressure-welded Connector for the following applications.</p> <ul style="list-style-type: none"> • Extending the trunk line or a sub-trunk line  <ul style="list-style-type: none"> • T-branching from the trunk line or a sub-trunk line • T-branching a sub-branch line from a branch line 	No	Yes	No

■ For Sheathed Flat Cable

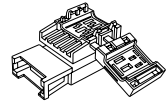
Name	Model	Appearance	Application	Communications Cables (Yes: Can be used. No: Cannot be used.)		
				VCTF 2-conductor cable	Standard Flat Cable	Sheathed Flat Cable
Sheathed Flat Cable Trunk Line Pressure-welded Connector	DCN5-TR4		<p>Use this Connector in a set with a DCN5-BR4 Sheathed Flat Cable Branch Line Pressure-welded Connector for the following applications.</p> <ul style="list-style-type: none"> • Extending the trunk line or a sub-trunk line • T-branching from the trunk line or a sub-trunk line • T-branching a sub-branch line from a branch line <p>Note Use the Connector to connect IP54 Bit Slave Units.</p>	No	No	Yes

Branch Line Pressure-welded Connectors

■ For Standard Flat Cable

Name	Model	Appearance	Application	Communications Cables (Yes: Can be used. No: Cannot be used.)		
				VCTF 2-conductor cable	Standard Flat Cable	Sheathed Flat Cable
Standard Flat Cable Branch Line Pressure-welded Connector	DCN4-BR4		<p>a. Use the Connector in a set with a DCN4-TR4 Standard Flat Cable Trunk Line Pressure-welded Connector for the following applications.</p> <ul style="list-style-type: none"> • Extending the trunk line or a sub-trunk line • T-branching from the trunk line or a sub-trunk line • T-branching a sub-branch line from a branch line <p>b. Use this Connector independently for the following applications.</p> <ul style="list-style-type: none"> • Connecting Communications Cable to a Master Unit, Word Slave Unit, or Repeater Unit • Connecting Communications Cable to a Multi-wiring Connector 	No	Yes	No

Note Although this Connector is called a Branch Line Pressure-welded Connector, it is also used for connecting Master Units, Word Slave Units, and Repeater Units.

■ For Sheathed Flat Cable

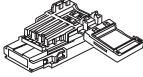
Name	Model	Appearance	Application	Communications Cables (Yes: Can be used. No: Cannot be used.)		
				VCTF 2-conductor cable	Standard Flat Cable	Sheathed Flat Cable
Sheathed Flat Cable Branch Line Pressure-welded Connector	DCN5-BR4		<p>a. Use this Connector in a set with a DCN5-TR4 Sheathed Flat Cable Trunk Line Pressure-welded Connector for the following applications.</p> <ul style="list-style-type: none"> • Extending the trunk line or a sub-trunk line • T-branching from the trunk line or a sub-trunk line • T-branching a sub-branch line from a branch line <p>b. Use this Connector independently for the following applications.</p> <ul style="list-style-type: none"> • Connecting Communications Cable to a Master Unit, Word Slave Unit, or Repeater Unit • Connecting Communications Cable to connectors for wiring <p>Note Use for connecting IP54 Bit Slave Units.</p>	No	No	Yes

Note Although this Connector is called a Branch Line Pressure-welded Connector, it is also used for connecting Master Units, Word Slave Units, and Repeater Units.

Multi-wiring Connector

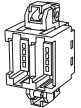
Name	Model	Appearance	Application	Communications Cables (Yes: Can be used. No: Cannot be used.)		
				VCTF 2-conductor cable	Standard Flat Cable	Sheathed Flat Cable
Multi-wiring Connector	DCN4-MD4		<p>This Connector connects two Branch Line Pressure-welded Connectors to two ports.</p> <p>Use Multi-wiring Connectors for multi-drop wiring of Master Units, Slave Units, or Repeater Units to trunk lines, sub-trunk lines, or branch lines.</p> <p>Note When the baud rate is 4 Mbits/s (mainly when Flat Cable is used), use this Connector to connect to Word Slave Units only.</p>	No	Yes	No

Special Tools

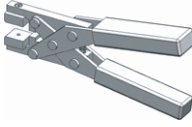
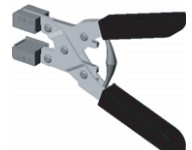
Name	Model	Appearance	Application	Communications Cables (Yes: Can be used. No: Cannot be used.)		
				VCTF 2-conductor cable	Standard Flat Cable	Sheathed Flat Cable
Pliers for Standard Flat Cable	DWT-A01		<p>Pliers for the following connectors:</p> <ul style="list-style-type: none"> • DCN4-TR4 Standard Flat Cable Trunk Line Pressure-welded Connector • DCN4-BR4 Standard Flat Cable Branch Line Pressure-welded Connector 	No	Yes	No
Pliers for Sheathed Flat Cable	DWT-A02		<p>Pliers for the following connectors:</p> <ul style="list-style-type: none"> • DCN5-TR4 Sheathed Flat Cable Trunk Line Pressure-welded Connector • DCN5-BR4 Sheathed Flat Cable Branch Line Pressure-welded Connector 	No	No	Yes

Terminal Block Adapter

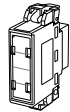
Name	Model	Appearance	Application	Communications Cables (Yes: Can be used. No: Cannot be used.)		
				VCTF 2-conductor cable	Standard Flat Cable	Sheathed Flat Cable
Terminal Block Adapter	DCN4-TB4		Used this Adapter to convert a communications connector on a Master Unit, Slave Unit, or Repeater Unit to a terminal block. The terminal size is M3.	Yes	No	No

Terminating Resistance

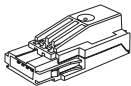
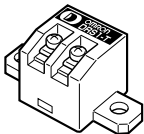
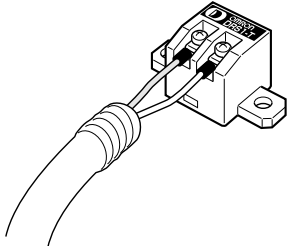
Name	Model	Appearance	Application	Communications Cables (Yes: Can be used. No: Cannot be used.)		
				VCTF 2-conductor cable	Standard Flat Cable	Sheathed Flat Cable
Standard Flat Cable Connector-type Terminating Resistor	DCN4-TM4		This is a connector-type terminating resistor. Connect a Trunk Line Pressure-welded Connector to the trunk line (or sub-trunk line) cable, and insert this Terminating Resistor into the connector.	No	Yes	No
Sheathed Flat Cable Connector-type Terminating Resistor	DCN5-TM4		This is a connector-type terminating resistor. Connect a Trunk Line Pressure-welded Connector to the trunk line (or sub-trunk line) cable, and insert this Terminating Resistor. Note Use the Terminating Resistor for IP54 Bit Slave Units.	No	No	Yes
Terminal Block-type Terminating Resistor	DRS1-T		This a terminal block with terminating resistance. 	Yes	No	No

1-3-3 Selecting Peripheral Devices Used According to Connection Configuration

When Using Standard Flat Cable or VCTF 2-conductor Cable

Connection configuration		Peripheral Devices used	
Connecting the Master Unit		Connecting the trunk line to the Master Unit	DCN4-BR4 Branch Line Pressure-welded Connector only or DCN4-TB4 Terminal Adapter
Connecting Slave Units or Repeater Units		Connecting branch lines or sub-branch lines to Slave Units or Repeater Units	DCN4-BR4 Branch Line Pressure-welded Connector only or DCN4-TB4 Terminal Adapter
Branching	T-branching	T-branching from a trunk or sub-trunk line	DCN4-TR4 Trunk Line Pressure-welded Connector + DCN4-BR4 Branch Line Pressure-welded Connector used in a set, or a commercially available terminal block
		T-branching a sub-branch line from a branch line	
	Multi-drop branching	Multi-drop branching of the trunk line or a sub-trunk line	DCN4-TB4 Terminal Adapter or DCN4-MD4 Multi-wiring Connector
		Multi-drop branching of a branch line or sub-branch line	
Extending the line length		Extending the trunk line or a sub-trunk line	DCN4-TR4 Trunk Line Pressure-welded Connector + DCN4-BR4 Branch Line Pressure-welded Connector used in a set
		Extending a branch line	
Terminating resistance		Installing terminating resistance for trunk lines or sub-trunk lines	DCN4-TM4 Connector-type Terminating Resistor or DRS1-T Terminal Block-type Terminating Resistor

When Using Sheathed Flat Cable

Connection configuration		Peripheral Devices used	
Connecting the Master Unit		Connecting the trunk line to the Master Unit	DCN5-BR4 Branch Line Pressure-welded Connector only or DCN4-TB4 Terminal Adapter
Connecting Slave Units or Repeater Units		Connecting branch lines or sub-branch lines to Slave Units or Repeater Units	DCN5-BR4 Branch Line Pressure-welded Connector only or DCN4-TB4 Terminal Adapter
Branching	T-branching	T-branching from a trunk or sub-trunk line	DCN5-TR4 Trunk Line Pressure-welded Connector + DCN5-BR4 Branch Line Pressure-welded Connector used in a set
		T-branching a sub-branch line from a branch line	
Extending lines		Extending the trunk line or a sub-trunk line	DCN5-TR4 Trunk Line Pressure-welded Connector + DCN5-BR4 Branch Line Pressure-welded Connector used in a set
		Extending a branch line	
Terminating resistance		Installing terminating resistance for trunk lines or sub-trunk lines	DCN5-TM4 Connector-type Terminating Resistor

1-3-4 CompoNet Slave Unit Functions

Yes: Supported, ---: Not supported.

Function	Units		CompoNet Slave Units			
	Digital I/O Slave Units		Bit Slave Units		Analog I/O Slave Units	
	Input Units	Output Units	Input Units	Output Units	Input Units	Output Units
Operation Time Monitor	Yes				---	
Contact Operation Monitor	Yes				---	
Total ON Time Monitor	Yes				---	
Automatic Baud Rate Detection			Yes			
Unit ON Time Monitor			Yes			
Naming Units			Yes			
Naming Connected Devices			Yes			
Network Power Voltage Monitor			Yes			
I/O Power Status Monitor	Yes				---	
Communications Error History Monitor			Yes			
Input Filter	Yes	---	Yes	---	---	
Communications Error Output	---	Yes	---	Yes	---	Yes
Preventing Malfunctions Caused by Inrush Current at Startup	Yes	---	Yes	---	---	---
Sensor Power Short-circuit Detection	---		Yes	---	---	
External Load Short-circuit Detection	---				Yes	---
Expansion Using Expansion Units	Yes				---	
Scaling	---				Yes	
Last Maintenance Date			Yes			
Cumulative Counter	---				Yes	
Moving Average	---				Yes	---
Setting the Number of AD Conversion Points	---				Yes	---
Rate of Change	---				Yes	---
Comparator	---				Yes	---
Peak/Bottom Hold	---				Yes	---
Top/Valley Hold	---				Yes	---
Disconnected Line Detection	---				Yes	---
User Adjustment	---				Yes	Yes

Note The Contact Operation Monitor and the Total ON Time Monitor cannot be used at the same time for a single contact.

1-4 Overview of Design Flow

Perform the following steps to design the system.

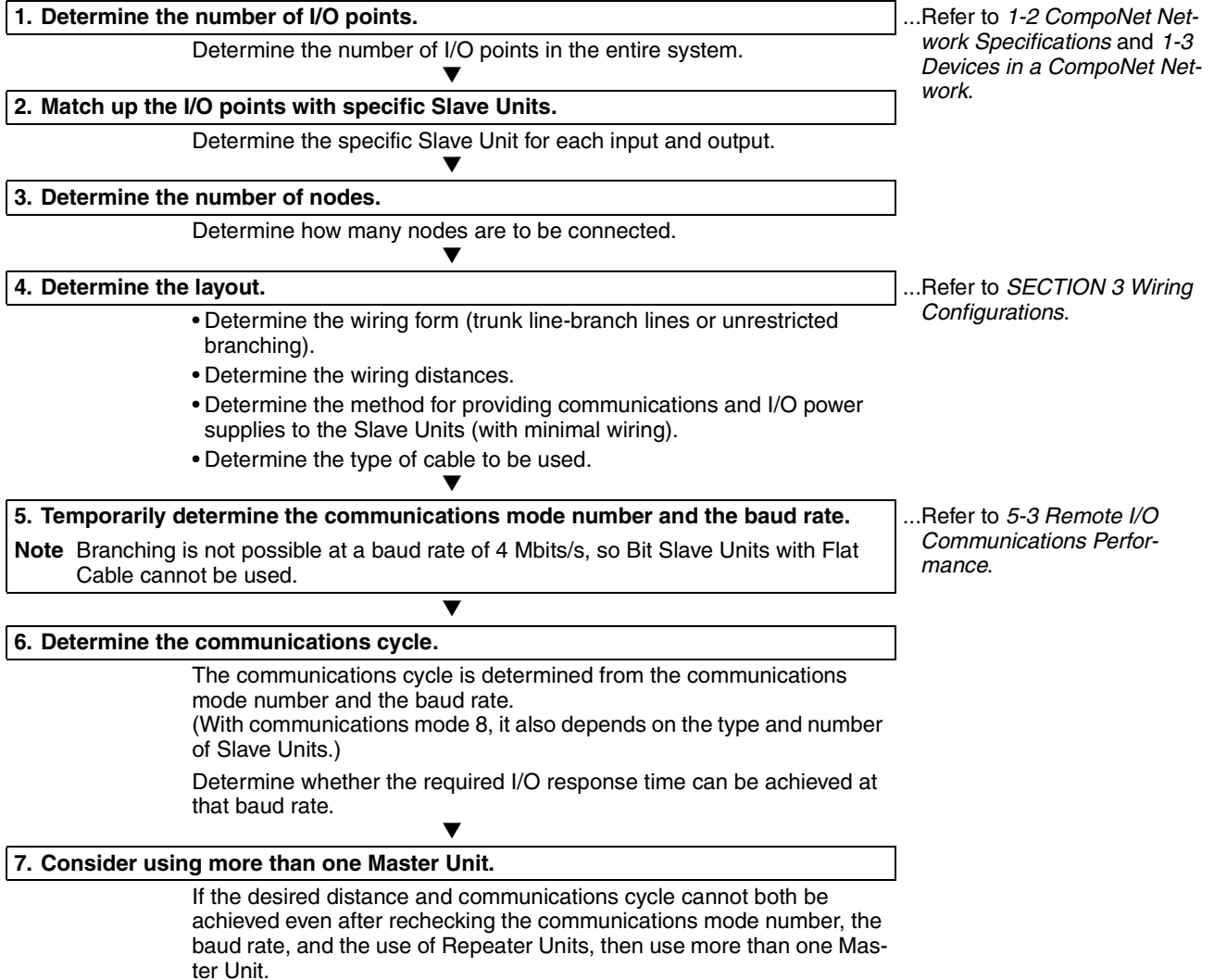

1-5 Overview of Operating Procedure

Follow the steps below to install and use a CompoNet Network.

- 1. Install and wire the system.**

Wire the network, the communications power supply, and the I/O power supply.

▼
- 2. Select the communications mode number on the front of the Master Unit.**

Set the communications mode number to 0, 1, 2, 3, or 8.

▼
- 3. Make the following settings on the DIP switch on the front of the Master Unit.**

SW1 (DR0) and SW2 (DR1): Set the baud rate.
 SW3 (ESTP): Set whether communications are to stop when an error occurs.
 SW4 (REGS): Enable or disable the Registration Table.

▼
- 4. Set the unit number on the front of the Master Unit.**

Set a number from 0 to 95.

▼
- 5. Set the Slave Unit node addresses.**

Set a node addresses from 0 to 63 for Word Slave Units and from 0 to 127 for Bit Slave Units.

▼
- 6. Connect the computer running CompoNet Support Software to the PLC where the Master Unit is mounted.**

...CompoNet Support Software Operation Manual

▼
- 7. Turn ON the power to the PLC.**

▼
- 8. Using CompoNet Support Software, edit and download the Master Unit device parameters.**

 1. Connect online to the PLC where the Master Unit is mounted.
 2. In the Online Connection Information Window, right-click the Master Unit under the connected PLC, and then select Connect.
 3. Right-click the Master Unit under the connected PLC, and select Transfer [Network to Computer].
 4. Double-click the Master Unit in the Network Configuration Window, and then edit and download the device parameters.

▼
- 9. Turn OFF the power to the PLC.**

▼
- 10. Remote I/O communications will start when all registered Slave Units are participating.**

▼
- 11. Using CompoNet Support Software, monitor the participation status of the Slave Units.**

 1. While online, upload the network configuration.
 2. Right-click the Master Unit in the Network Configuration Window and select Monitor to monitor the participation status on the Status/Unit Status Tab Page.

1-6 Design and Operating Procedure Examples

1-6-1 Design

I/O Capacity

Establish the I/O correspondences for each Slave Unit. Determine how many Word and Bit Slave Units are to be connected, and calculate the current consumption for the communications power supply.

■ Units Used

I/O capacity	Slave Unit type	Model (specifications)	Number of Units	Current consumption
16 inputs	Word Slave Units	CRT1-ID16 (16 DC inputs, NPN)	1	85 mA
16 inputs and 8 outputs		CRT1-ID16 (16 DC inputs, NPN) + XWT-OD08 (8 transistor outputs, NPN)	1 of each	85 mA + 5 mA = 90 mA
16 outputs		CRT1-OD16 (16 transistor outputs, NPN)	1	85 mA
2 inputs × 2	Bit Slave Units	CRT1B-ID02S (2 DC inputs, sensor connector type, NPN)	2	80 mA + I/O current consumption 76 mA (Sensor example: 35 mA × 2 + input current 3 mA × 2) Note The total for two Units is 160 mA + 152 mA.
2 outputs		CRT1B-OD02S (2 transistor outputs, sensor connector type, NPN)	1	75 mA + I/O current consumption 160 mA (actuator) Example: 80 mA × 2 (See note.)
			Total	495 mA + 312 mA for I/O = 807 mA

Note With Bit Slave Units, the current consumption for both external I/O (sensors and actuators) and the communications power supply is supplied from the power supply connected to the Master Unit (via Flat Cable). Therefore, add the following external I/O current consumption.

Sensor current consumption × 2, actuator current consumption × 2

Word Slave Units × 3 nodes; Bit Slave Units × 3 nodes

At the same time, prepare a 24-VDC power supply with an output current of at least 0.9 A for the communications power supply.

■ Required Peripheral Devices

Specifications	Model	Quantity	Remarks
Trunk Line Pressure-welded Connectors	DCN4-TR4	7	Order in units of ten.
Branch Line Pressure-welded Connectors	DCN4-BR4	10	Order in units of ten.
Connector-type Terminating Resistor	DCN4-TM4	1	Order in units of ten.
Flat Cable	DCA4-4F10	1	Order in increments of 100 m.
Pliers	DWT-A01	1	---

System Configuration

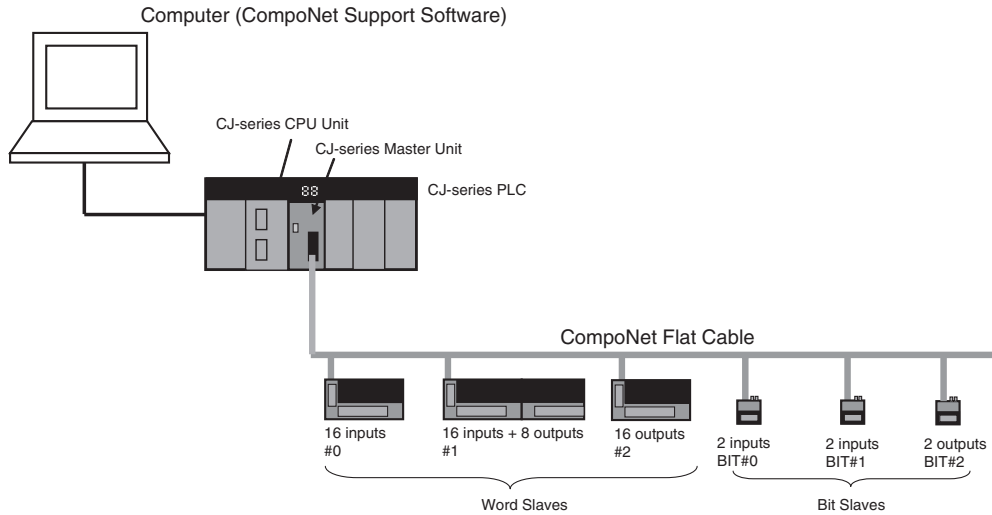

Layout

- Wiring form: Branching from trunk line to branch lines, with no sub-branch lines
- Wiring distance: 30 m or less, so any cable type or baud rate is acceptable.
- Communications Power Supply to Slave Units: Supplied to all collectively.

Cable type		VCTF 2-conductor cable					Standard or Sheathed Flat Cable				
Baud rate		4 Mbits/s	3 Mbits/s	1.5 Mbits/s	93.75 kbits/s	4 Mbits/s	3 Mbits/s	1.5 Mbits/s	93.75 kbits/s		
Wiring form	No branch lines	All can be used.									
	With branch lines	Without sub-branch lines (branch line extension)	Not supported.	Supported (0.5 m).	Not supported.	Supported (2.5 m)	Supported (6 m).	Not supported.	Supported (0.5 m).	Supported (2.5 m).	Supported (unrestricted branching).
		With sub-branch lines	Not supported.					Not supported.		Supported (2.5 m).	Supported (unrestricted branching).
Maximum length for trunk lines and sub-trunk lines		30 m		100 m	30 m	500 m	30 m			200 m (unrestricted branching)	

■ Remarks

Wiring Form

- When there are no branch lines: Any combination of cable types and baud rates is supported.
- When there are branch lines (e.g., when a Bit Slave Unit with attached cable is used): A baud rate of 4 Mbit/s cannot be used for either VCTF 2-conductor cable or Standard or Sheathed Flat Cable. With VCTF 2-conductor cable, trunk lines and sub-trunk lines must not be longer than 30 m when the baud rate is 1.5 Mbit/s.
- When there are sub-branch lines from the branch lines: Standard or Sheathed Flat Cable must be used, and the baud rate must be either 1.5 Mbits/s or 93.75 kbits/s.

Maximum Length for Trunk Lines and Sub-trunk Lines

- When the lines are 30 m or less: Any combination of cable types and baud rates is supported.
- When a distance longer than 30 m is required:
 - When VCTF 2-conductor cable is used: The baud rate must be 1.5 Mbits/s, with no branching. (The cable length can be up to 100 m.)
 - When Standard or Sheathed Flat Cable is used: The baud rate must be 93.75 bits/s. (The cable length can be up to 200 m when unrestricted branching is used.)

Types of Cable

Flat Cable is used in this example, because IP20 Bit Slave Units are used and the communications power supply is provided collectively through the communications cables.

Item		Cable type			
		VCTF 2-conductor cable	Standard Flat Cable	Sheathed Flat Cable	
Application		<ul style="list-style-type: none"> • Wiring between the Master Unit and Repeater Units • Wiring Slave Units downstream from a Repeater Unit 			
		<ul style="list-style-type: none"> • When using commercially available cable is desirable. • To provide communications power separately. • When not using Bit Slave Units. 	<ul style="list-style-type: none"> • To supply communications power to all Slave Units through the communications cable. • When using Bit Slave Units. 	<ul style="list-style-type: none"> • To supply communications power to all Slave Units through the communications cable. • When using Bit Slave Units. • Applications in environments that require IP54 compliance (drip-proof, splash-proof). 	
Applicable Slave Units	Word Slave Units		Supported	Supported	
	Bit Slave Units	IP20 Bit Slave Units	Not supported. Note Bit Slave Units cannot be used with VCTF 2-conductor cable. Bit Slave Units are sold with Standard or Sheathed Flat Cable already connected.	Supported	Not supported.
		IP54 Bit Slave Units		Not supported.	Supported
Wiring method for communications power supply		Wired separately from the communications cable.	Same as communications cable. (The communications power supply is connected to the communications power supply connector on the Master Unit and the downstream port communications power supply connectors on Repeater Units.)		
Master Unit position		End of trunk line	Baud rate other than 93.75 kbits/s: End of trunk line 93.75 kbits/s: Anywhere in network		
Branch lines		4 Mbits/s: Not supported. Baud rates other than 4 Mbits/s: Supported	4 Mbits/s: Not supported. Baud rates other than 4 Mbits/s: Supported 93.75 kbits/s: Unrestricted branching		
Branching from branch lines Multi-wiring	Multidrop connections on branch lines		1.5 Mbits/s: Supported (3 per branch)	1.5 Mbits/s: Supported (3 per branch) 93.75 kbits/s: Unrestricted branching	
	Sub-branch lines		Not supported.	1.5 Mbits/s: Supported (3 per branch) 93.75 kbits/s: Unrestricted branching	
Communications distance	4 Mbits/s		Trunk line/sub-trunk line: 30 m max.	Trunk line/sub-trunk line: 30 m max.	
	3 Mbits/s		Trunk line/sub-trunk line: 30 m max.	Trunk line/sub-trunk line: 30 m max.	
	1.5 Mbits/s		Trunk line/sub-trunk line: 100 m max. without branches, 30 m max. with branches	Trunk line/sub-trunk line: 30 m max.	
	93.75 kbits/s		Trunk line/sub-trunk line: 500 m max.	Total wiring length: 200 m max.	

Communications Mode Number and Baud Rate

- Communications mode number: 3 (Mode 3 is selected because Word Slave Units and Bit Slave Units are used.) Memory can be allocated in the Special I/O Unit portion of the CIO Area, so a CompoNet Support Software setting is not required.
- Baud rate: 3 Mb/s (Branch lines are used, but not sub-branch lines. Also, this baud rate can be used with a maximum trunk line length of 30 m.)

Communications Cycle Time

The communications cycle time is 2.5 ms, at a baud rate of 3 Mb/s in communications mode 3. Base calculations on a communications cycle time of 2.5 ms. (For details on I/O response times, refer to 5-3 *Remote I/O Communications Performance*.)

Slave Unit type and maximum number of nodes	Baud rate Communications mode No.	Communications cycle time (with message communications)			
		4 Mb/s	3 Mb/s	1.5 Mb/s	93.75 kb/s
Word Slave Units, max. 8 nodes input and 8 nodes output	0	0.9 ms	0.9 ms	1.5 ms	19.6 ms
Word Slave Units, max. 16 nodes input and 16 nodes output	1	1.0 ms	1.2 ms	2.3 ms	29.8 ms
Word Slave Units, max. 32 nodes input and 32 nodes output	2	1.3 ms	1.6 ms	4.0 ms	50.6 ms
Word Slave Units, max. 16 nodes input and 16 nodes output; Bit Slave Units, max. 64 nodes input and 64 nodes output	3	2.0 ms	<u>2.5 ms</u>	5.8 ms	70.7 ms
Word Slave Units, max. 64 nodes input and 64 nodes output; Bit Slave Units, max. 128 nodes input and 128 nodes output	8	0.55 ms + added time for number of and types of Slave Units	0.66 ms + added time for number of and types of Slave Units	1.58 ms + added time for number of and types of Slave Units	21.09 ms + added time for number of and types of Slave Units

Note When less than the maximum number of nodes is used, the communications cycle time is progressively shortened as the communications mode number becomes smaller and as the baud rate is increased.

Registration Tables

Registration tables are used and they must be generated automatically from CompoNet Support Software.

- Registered Slave Unit Participation Standby Mode: Enabled

Communications Error Communications Stop Mode: Enabled

I/O Allocations

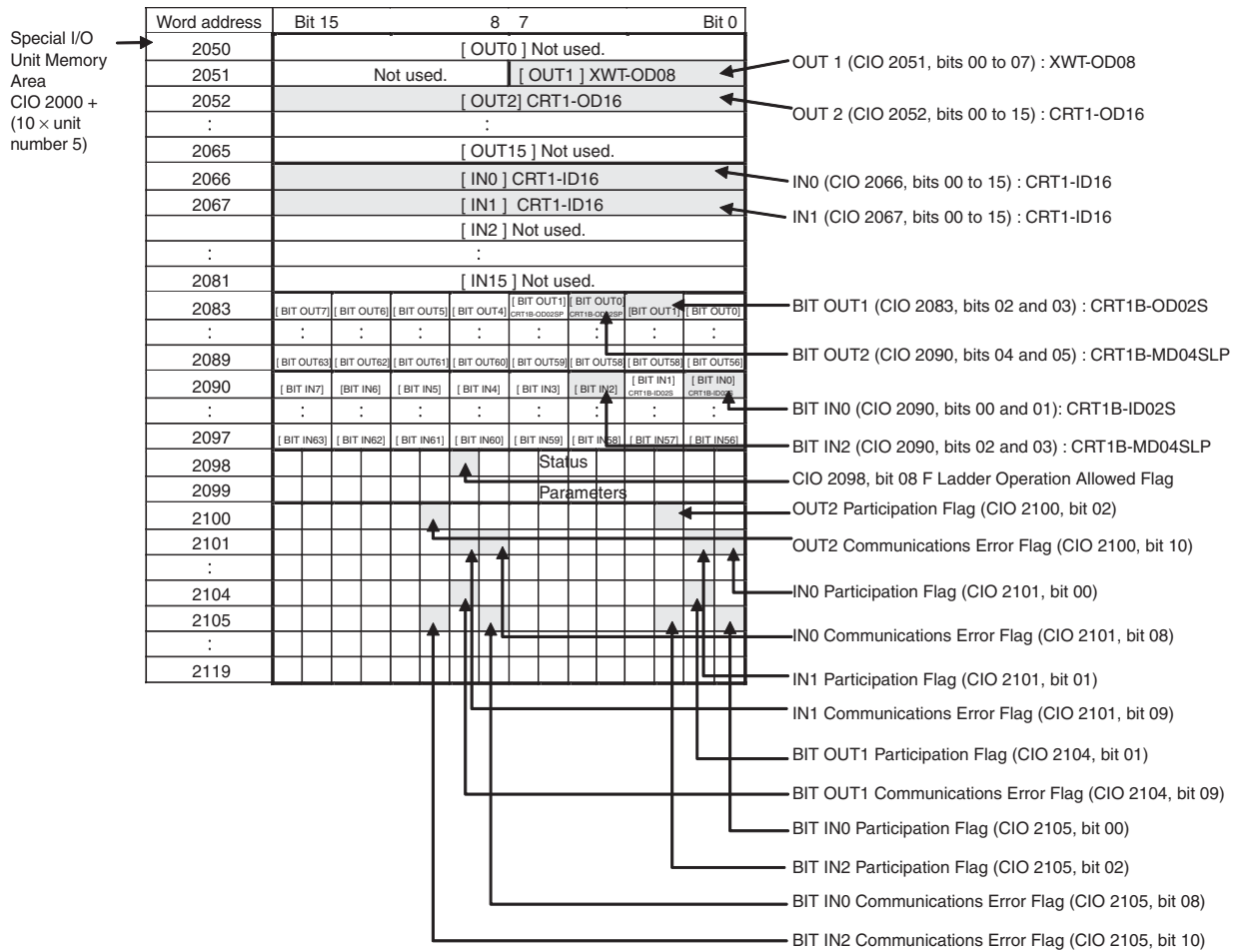

Ladder Programming Example

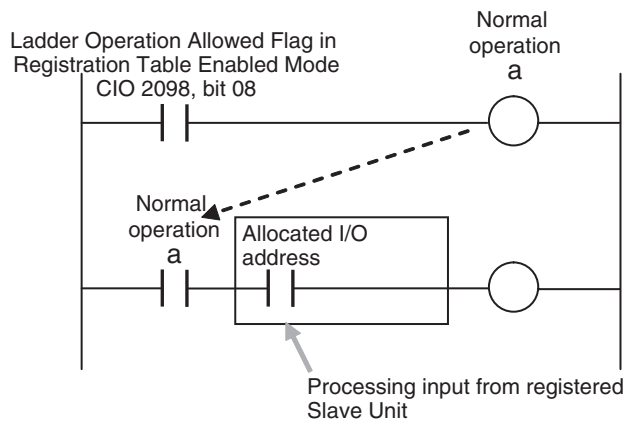

1-6-2 Operating Procedure

1,2,3... 1. Perform the installation and wiring.

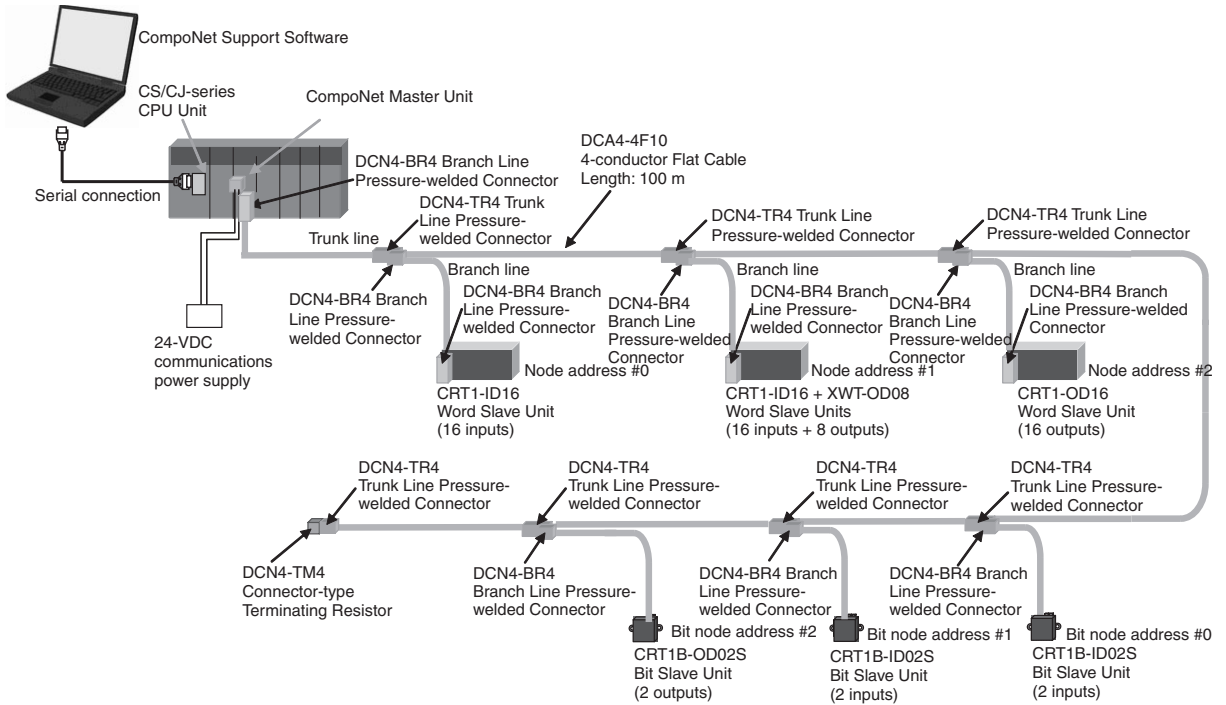

2. Set the communications mode number on the front of the Master Unit (example: 3).

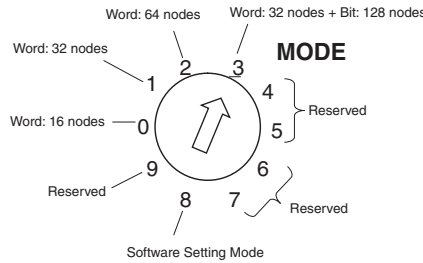

3. Set the DIP switch on the front of the Master Unit as follows:

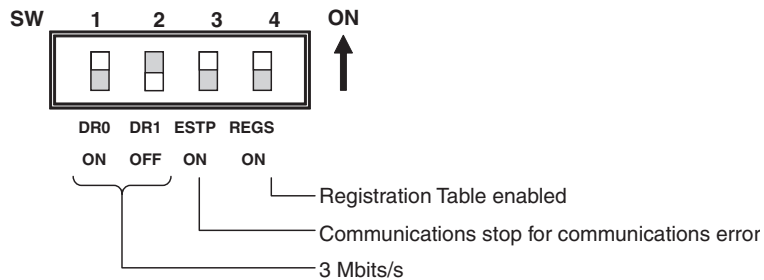

• Baud Rate Setting

SW1	SW2	Setting
DR0	DR1	
OFF	OFF	4 Mbits/s (default)
ON	OFF	3 Mbits/s
OFF	ON	1.5 Mbits/s
ON	ON	93.75 kbits/s

- Communications Error Communications Stop Mode (Stopping All Remote I/O Communications when a Communications Error Occurs in One Slave Unit) and Registration Table Enable Setting

SW	Name	ON	OFF
3	ESTP (Communications Error Communications Stop Mode)	Communications stop when a communications error occurs.	Communications do not stop when a communications error occurs.
4	REGS (Registration Table Enable Setting)	Registration Table enabled.	Registration Table disabled.

- Set the unit number on the front of the Master Unit.
The unit number is set to 5 in this example. Therefore the first address is CIO 2050.
- Set the Slave Unit node addresses.

Model	Node address
CRT1-ID16	Node address #0
CRT1-ID16 + XWT-OD08	Node address #1
CRT1-OD16	Node address #2
CRT1B-ID02S	Bit node address #0
CRT1B-ID02S	Bit node address #1
CRT1B-OD02S	Bit node address #2

- Connect the CompoNet Support Software to the CPU Unit's serial communications port.
- Turn ON the power to the PLC.
- Connect the CompoNet Support Software online and edit and download the Master Unit device parameters.
 - Connect online to the PLC where the Master Unit is mounted.
 - In the Online Connection Information Window, right-click the Master Unit under the connected PLC, and then select Connect.
 - Right-click the Master Unit under the connected PLC, and select Transfer [Network to Computer].

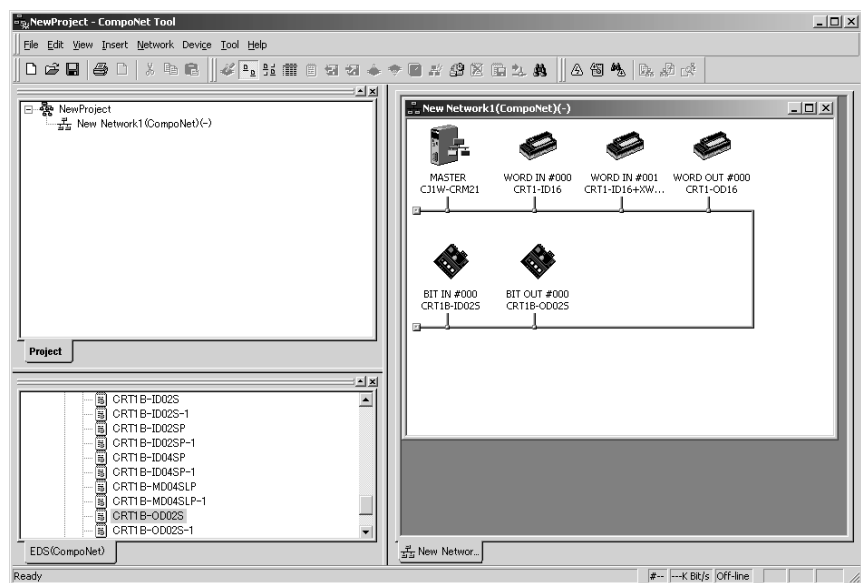

- (4) Double-click the Master Unit in the Network Configuration Window. Then, on the General Master Unit Tab Page, select the Slave Units to be registered and create a Registration Table.
 - (5) Open the Detailed Settings Dialog Box and enable the Registered Slave Unit Participation Standby Mode.
 - (6) Click the Download Button to download the Master Unit device parameters.
9. Cycle the power to the PLC.
 10. Remote I/O communications will start when all registered Slave Units have started participating.

MS and NS Indicators

- Normal Operation

LED	Status	Contents	
MS	Lit green	Master Unit normal	Power is being supplied and the Master Unit hardware and settings are normal.
NS	Lit green	Remote I/O communications normal	Power is being supplied, remote I/O communications have started, there are no communications errors at any Slave Unit or Repeater Unit, there are no Registration Table errors, and there are no node address duplication errors for Slave Units or Repeater Units.

- Error Operation

LED	Status	Contents	
MS	Flashing red	Non-fatal error	Communications mode number or unit number setting error
	Lit red	Fatal error	Hardware error
NS	Flashing green	I/O communications stopped	Remote I/O communications have not started or have stopped (for a reason other than a communications error).
	Flashing red	Communications error	A communications error has occurred for one or more Slave Units or Repeater Units. A verification error (non-existent or unregistered Slave Unit) has occurred for one or more Slave Units. Communications have stopped due to a communications error. An illegal configuration error (number of Repeater Units) has occurred. An address duplication error has occurred at one or more Slave Units or Repeater Units.
	Lit red	Address duplication error	An error has occurred in the communications circuit.

Indicators and Seven-segment Display

• Normal Operation

Indicators	Status	Display	Seven-segment display	Contents
_0 to _3 lit	Remote I/O communications are starting.	_0		4 Mbits/s
		_1		3 Mbits/s
		_2		3 Mbits/s
		_3		93.75 kbits/s

• Error Operation

Indicators	Status	Seven-segment display			Contents	
_0 to _3 lit	Remote I/O communications are not starting.	_0			4 Mbits/s	
		_1			3 Mbits/s	
		_2			3 Mbits/s	
		_3			93.75 kbits/s	
d9 - i/o/bi/bo/r - Node address	A communications error has occurred.	d9		i		Input
			o		Output	
			bi		Bit input	
			bo		Bit output	
			r		Repeater Unit	
d0 - i/o/bi/bo/r - Node address	The same address is being used by two different Units.	d0		Same as above.		
d5 - i/o/bi/bo/r - Node address	A non-existent Slave Unit verification error has occurred.	d5		Same as above.		
d6 - i/o/bi/bo/r - Node address	An unregistered Slave Unit verification error has occurred.	d6		Same as above.		
A0	Communications have stopped due to a communications error.	A0		---		
E4	Software set data is illegal.	E4		---		
E8	Registered Table data is illegal.	E8		---		

11. Using CompoNet Support Software, monitor the participation status of Slave Units.
 - (1) While online, upload the network configuration.
 - (2) Right-click the Master Unit in the Network Configuration Window, and select Monitor.
 - (3) Monitor Slave Unit participation status on the Status Tab Page.

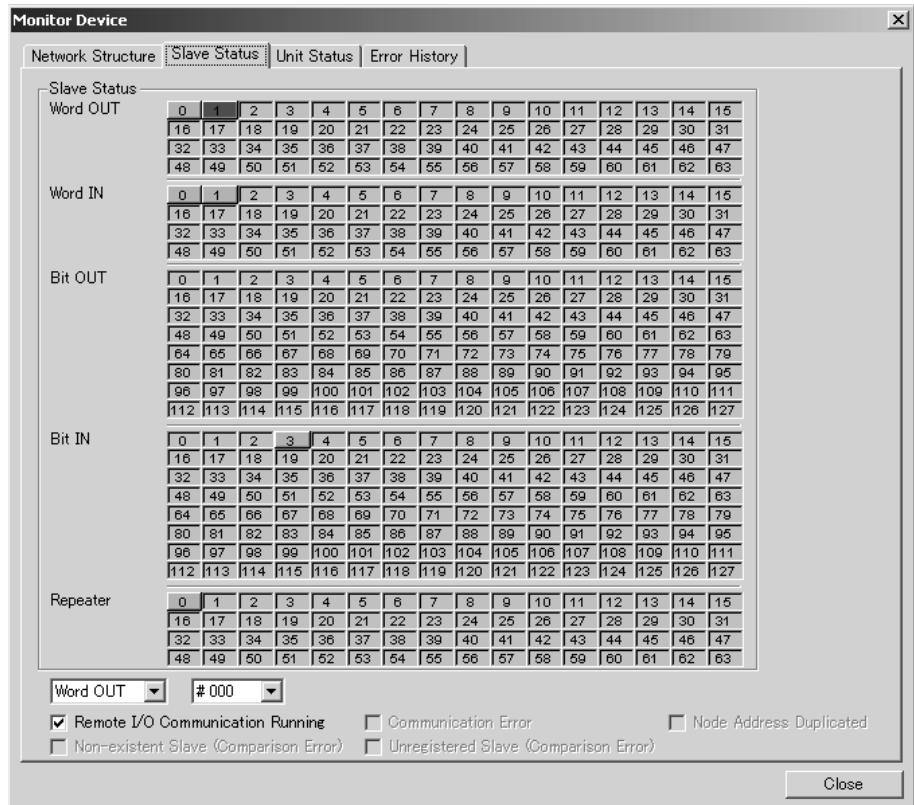

A list of node addresses will be displayed showing the participation status for each node: participating (blue), disconnected (red), or not participating (gray).

- (4) Monitor the status of all Master Unit communications on the Unit Status Tab Page.

SECTION 2

Master Units

This section provides the specifications of the CompoNet Master Units

2-1	Master Unit Specifications	40
2-1-1	Specifications	40
2-1-2	Component Names and Functions	41
2-1-3	Display Section	43
2-1-4	Switch Settings	45
2-1-5	Terminal Arrangement	47
2-1-6	Dimensions	48

2-1 Master Unit Specifications

2-1-1 Specifications

Item	Specification	
Model	CS1W-CRM21	CJ1W-CRM21
Applicable PLC	CS Series	CJ Series
Unit classification	CS-series Special I/O Unit	CJ-series Special I/O Unit
Current consumption (Power supplied from PLC's Power Supply Unit)	400 mA max. at 5 VDC	400 mA max. at 5 VDC
Weight	190 g max. (Master Unit only)	130g max. (Master Unit only)
Communications power supply connector	One communications power supply connector for Slave Units and Repeater Units on the trunk line when using Flat Cable Note The Master Unit does not required communications power.	
Communications power supply connector allowable current capacity	5 A max.	5 A max.
Maximum number of mountable Master Units	One word number assigned: 80 Units Two word numbers assigned: 48 Units Four word numbers assigned: 24 Units Eight word numbers assigned: 12 Units	One word number assigned: 40 Units Two word numbers assigned: 40 Units Four word numbers assigned: 24 Units Eight word numbers assigned: 12 Units
Mounting location	According to CS/CJ-series Special I/O Unit specifications.	
Communications power ON/OFF monitoring	The ON/OFF status of the communications power supply can be detected at the communications power supply connector.	
Data stored in Master Unit (built-in EEPROM)	1) The following device parameters: <ul style="list-style-type: none"> • Registration Table • Registration Table Check Type • Registered Slave Unit Participation Monitoring Time, Registered Slave Unit Participation Standby Mode, and Event Disable Setting • Software Settings Table • Communications Error Communications Stop Mode • Communications Error Input Data Zero Clear Mode • Network settings 2) Part of error history (depends on type of error; mainly serious error related to communications stopping)	
Noise immunity	Conforms to IEC 61000-4-4 2kV (applied to PLC power supply)	
Vibration resistance	Same as general PLC specifications.	
Shock resistance	Same as general PLC specifications.	
Dielectric strength	500 VAC (between isolated circuits)	
Insulation resistance	20 MΩ min. (between isolated circuits)	
Ambient operating temperature	0 to 55°C	
Ambient operating humidity	10% to 90% (with no condensation)	
Ambient operating atmosphere	No corrosive gases	
Storage humidity	-20 to 75°C	

2-1-2 Component Names and Functions

CS-series Master Unit

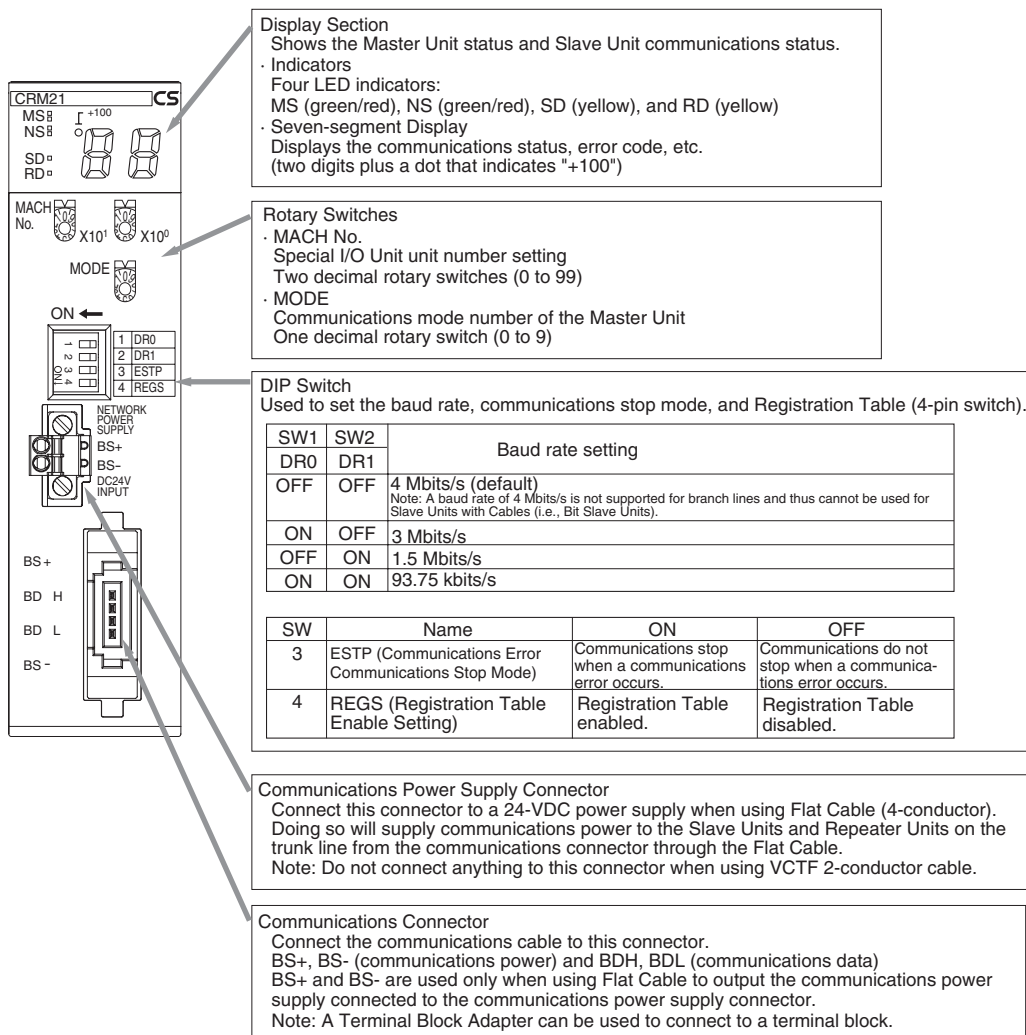

CJ-series Master Unit

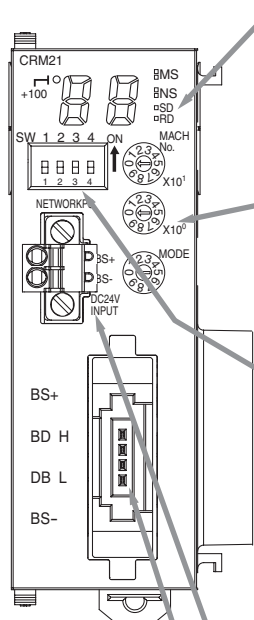

Display Section
Shows the Master Unit status and Slave Unit communications status.

- Indicators
Four LED indicators:
MS (green/red), NS (green/red), SD (yellow), and RD (yellow)
- Seven-segment Display
Displays the communications status, error code, etc.
(two digits plus a dot that indicates "+100")

Rotary Switches

- MACH No.
Special I/O Unit unit number setting
- Two decimal rotary switches (0 to 99)
- MODE
Communications mode number of the Master Unit
- One decimal rotary switch (0 to 9)

DIP Switch
Used to set the baud rate, communications stop mode, and Registration Table (4-pin switch).

SW1 DR0	SW2 DR1	Baud rate setting
OFF	OFF	4 Mbits/s (default) <small>Note: A baud rate of 4 Mbits/s is not supported for branch lines and thus cannot be used for Slave Units with Cables (i.e., Bit Slave Units).</small>
ON	OFF	3 Mbits/s
OFF	ON	1.5 Mbits/s
ON	ON	93.75 kbits/s

SW	Name	ON	OFF
3	ESTP (Communications Error Communications Stop Mode)	Communications stop when a communications error occurs.	Communications do not stop when a communications error occurs.
4	REGS (Registration Table Enable Setting)	Registration Table enabled.	Registration Table disabled.

Communications Power Supply Connector
Connect this connector to a 24-VDC power supply when using Flat Cable (4-conductor). Doing so will supply communications power to the Slave Units and Repeater Units on the trunk line from the communications connector through the Flat Cable.
Note: Do not connect anything to this connector when using VCTF 2-conductor cable.

Communications Connector
Connect the communications cable to this connector.
BS+, BS- (communications power) and BDH, BDL (communications data)
BS+ and BS- are used only when using Flat Cable to output the communications power supply connected to the communications power supply connector.
Note: A Terminal Block Adapter can be used to connect to a terminal block.

2-1-3 Display Section

Communications Indicators





The following LED indicators are provided for communications.

MS (Module Status): Shows the status of the node itself. (Two colors: green and red)

NS (Network Status): Shows the status of communications. (Two colors: green and red)

SD (Send Data): Shows Master Unit transmission status. (One color: yellow)

RD (Receive Data): Shows Master Unit reception status. (One color: yellow)

Indicator	Status	Status definition	Meaning
MS	Lit green	Normal	The Unit is operating normally.
	Lit red	Fatal error	Unit hardware error, such as a watchdog timer error (WDT)
	Flashing red	Non-fatal error	Communications mode number or unit number setting error
	Not lit	Power OFF/Preparing	Power OFF, resetting, or initializing
NS	Lit green	Online, with remote I/O communications in progress	Power is being supplied, remote I/O communications have started, there are no communications errors at any Slave Unit or Repeater Unit, there are no Registration Table errors, and there are no node address duplication errors for Slave Units or Repeater Units.
	Flashing green	Online, with no remote I/O communications in progress	Remote I/O communications have not started or have stopped (for a reason other than a communications error).
	Lit red	Fatal communications error	An error has occurred in the communications circuit.
	Flashing red	Non-fatal communications error	A communications error has occurred at one or more Slave Units or Repeater Units. A verification error (non-existent or unregistered Slave Unit) has occurred at one or more Slave Units. Communications have stopped due to a communications error. An illegal configuration error (number of Repeater Units) has occurred. An address duplication error has occurred at one or more Slave Units or Repeater Units.
	Not lit	Power OFF/Preparing	Power OFF, resetting, or initializing
SD	 Lit yellow	Normal transmission	Frames are being sent normally from the Master Unit.
	 Not lit	No transmission	The Master Unit is not sending data.
RD	 Lit yellow	Normal reception	Frames are being sent normally from a Slave Unit.
	 Not lit	No reception	The Master Unit is not receiving data.

The indicator flashing intervals are approximately 0.5 s lit and 0.5 s not lit.

Seven-segment Display

- The seven-segment display shows the baud rate during normal transmission. It lights while remote I/O communications are in progress and flashes while they are stopped.
- When a communications error occurs, the following information is displayed in order: Error code (2 digits hexadecimal) - Type of Slave Unit at error node - Node address (2 digits decimal).
- When an error other than a communications error occurs, the error code (2 digits hexadecimal) is displayed.

Status	Display contents	Display	Actual display	Contents				
Normal	Remote I/O communications in progress	Baud rate display lit.	_0	Lit	4 Mbits/s			
			_1	Lit	3 Mbits/s			
			_2	Lit	1.5 Mbits/s			
			_3	Lit	93.75 kbits/s			
	Remote I/O communications stopped	Baud rate display flashing.	_0	Flashing	4 Mbits/s			
			_1	Flashing	3 Mbits/s			
			_2	Flashing	1.5 Mbits/s			
			_3	Flashing	93.75 kbits/s			
Error	Initialization error	Error code	The error code is displayed in hexadecimal (lit).					
	Communications error	The error code, Slave Unit type, and applicable node address are alternately displayed.	The error code (2 digits hexadecimal), Slave Unit type, and applicable node address (1-bit dot notation for the 100 position for 3-digit decimal) are alternately displayed (i.e., the cause of the error). Note The error codes are different for inputs and outputs.					
			Example	Error code		Slave Unit type		
				Display	Actual display	Display	Actual display	Meaning
			A communications error occurred.	d9		i		IN
						o		OUT
						bi		Bit input
						bo		Bit output
	r					Repeater Unit		
	A node address duplication error occurred.	d0		Same as above.				
A non-existent Slave Unit verification error occurred.	d5		Same as above.					
An unregistered Slave Unit verification error occurred.	d6		Same as above.					
Error during operation Note An error during operation is an error other than a communications error that occurs during Unit operation.	Error code	The error code is displayed in 2-digit hexadecimal (lit).						
		Example	Error code		---			
			Display	Actual display				
		Communications have stopped due to a communications error.	A0		---			
		Software set data is illegal.	E4		---			
Registered Table data is illegal.	E8		---					

2-1-4 Switch Settings

Unit Number Switches (MACH No.) Special I/O Unit unit number setting: Two decimal rotary switches (0 to 99)
This setting is read when the power supply is turned ON to the PLC.

MODE Switch Master Unit communications mode number setting: One decimal rotary switch (0 to 9)
This setting is read when the power supply is turned ON to the PLC.

Communications mode No.	Name	Connectable node addresses	Control points	Memory areas	Number of unit numbers used per Master Unit
0	Communications mode No. 0	Word Slave Units: IN0 to IN7 and OUT0 to OUT7	Word Slave Units: 128 inputs and 128 outputs	Special I/O Unit Area (First word depends on unit number of Master Unit.)	2
1	Communications mode No. 1	Word Slave Units: IN0 to IN15 and OUT0 to OUT15	Word Slave Units: 256 inputs and 256 outputs		4
2	Communications mode No. 2	Word Slave Units: IN0 to IN31 and OUT0 to OUT31	Word Slave Units: 512 inputs and 512 outputs		8
3	Communications mode No. 3	Word Slave Units: IN0 to IN15 and OUT0 to OUT15 Bit Slave Units: IN0 to IN63 and OUT0 to OUT63	Word Slave Units: 256 inputs and 256 outputs Bit Slave Units: 128 inputs and 128 outputs		8
4	Reserved	---	---	---	---
5	Reserved	---	---	---	---
6	Reserved	---	---	---	---
7	Reserved	---	---	---	---
8	Software Setting Mode	Can be set within the following ranges: Word Slave Units: IN0 to IN63 and OUT0 to OUT63 Bit Slave Units: IN0 to IN127 and OUT0 to OUT127	Can be set within the following ranges: Word Slave Units: 1,024 inputs and 1,024 outputs Bit Slave Units: 256 inputs and 256 outputs	Can be allocated anywhere in the CIO, DM, WR, or HR Areas. Note Status and parameters are allocated in the Special I/O Unit Area.	1
9	Reserved	---	---	---	---

- Note**
- (1) In a CompoNet Network, Word Slave Units have 16 bits per node address.
 - (2) Do not set the reserved communications mode numbers (4 to 7 and 9). A communications mode setting error (H4 at the 7-segment LED indicator) will occur if any of these modes is set.

DIP Switch

This setting is read when the power supply is turned ON to the PLC.

Baud Rate Setting

SW1 DR0	SW2 DR1	Baud rate setting
OFF	OFF	4 Mbits/s (default)
ON	OFF	3 Mbits/s
OFF	ON	1.5 Mbits/s
ON	ON	93.75 kbits/s

Slave Units automatically detect the baud rate set on SW1 (DR0) and SW2 (DR2). It is not necessary to set the baud rate separately for any of the Slave Units.

Communications Error Communications Stop Mode Setting

SW	Name	ON	OFF
3	ESTP (Communications Error Communications Stop Mode)	Communications stop when a communications error occurs.	Communications do not stop when a communications error occurs.

When SW3 (ESTP) is turned ON, all remote I/O communications are stopped when a communications error occurs at any Slave Unit. (The Communications Error Communications Stop Flag at status bit 02 also turns ON.) When SW3 is turned OFF, remote I/O communications continue even if a communications error occurs at a Slave Unit.

Registration Table Enable Setting

SW	Name	ON	OFF
4	REGS (Registration Table Enable Setting)	Registration Table enabled.	Registration Table disabled.

When the power is turned ON with SW4 (REGS) turned ON, registration tables that have been edited or downloaded with CompoNet Support Software or that have been automatically generated are enabled. Only registered Slave Units are allowed to participate, and registered Slave Units are compared to actual Slave Units. If they do not agree, the Registered Table Verification Error Flag in status bit 01 turns ON.

2-1-5 Terminal Arrangement

Communications Power Supply Connector

This connector supplies communications power to Slave Units and Repeater Units connected to the trunk line.

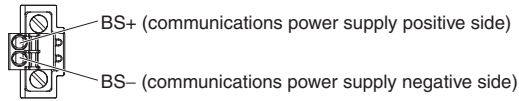

Note This connector does not supply power to the Master Unit.

Communications Connector

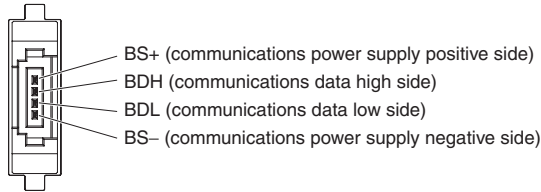

Note BS+ and BS- output the communications power supply connected to the communications power supply connector. (This is the communications power for Slave Units and Repeater Units connected to the trunk line.)

This connector does not supply power to the Master Unit.

2-1-6 Dimensions

CS1W-CRM21

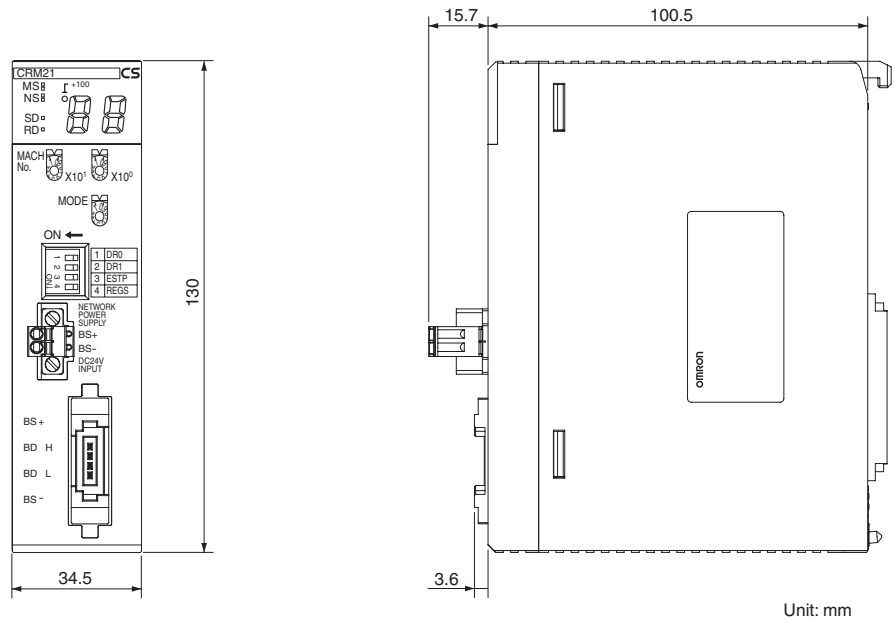

Unit: mm

CJ1W-CRM21

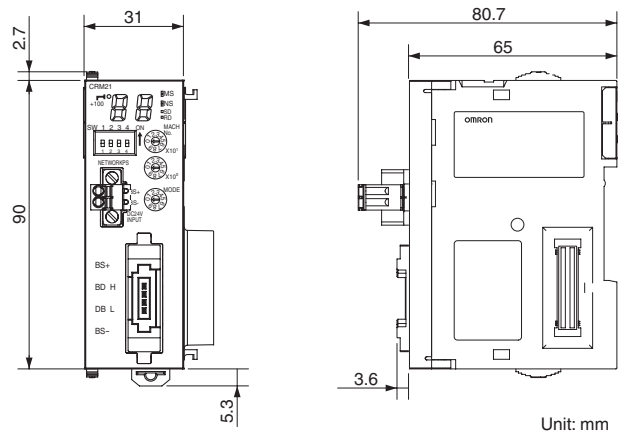

Unit: mm

SECTION 3

Wiring Configurations

This section describes the configurations of CompoNet Networks.

- 3-1 Wiring Formations 50
 - 3-1-1 Wiring Formations 50
- 3-2 CompoNet Network Wiring 51
 - 3-2-1 CompoNet Network Wiring System..... 51
 - 3-2-2 Cable Types..... 53
 - 3-2-3 Connection Methods..... 56
 - 3-2-4 Node Connection Methods 57
 - 3-2-5 Cable Branches..... 58
 - 3-2-6 Extending the Cable Length 60
 - 3-2-7 Connection Locations for Terminating Resistance..... 61
 - 3-2-8 Connection Locations for Communications Power Supply 63

3-1 Wiring Formations



3-1-1 Wiring Formations

There are two possible formation for a CompoNet Network.

- Trunk line-branch line formation
- Unrestricted wiring formation

The formation is determined by the type of cable and baud rate as shown below.

Cable type	Baud rate			
	4 Mbits/s	3 Mbits/s	1.5 Mbits/s	93.75 kbits/s
VCTF 2-conductor cable				
Flat Cable				

 : Trunk line-branch line formation
  : Unrestricted wiring formation

Trunk Line-Branch Line Formation

With this wiring formation, the trunk line is differentiated from branch lines. The Master Unit must be on one end of the network and there are branching restrictions.

The trunk line-branch line formation is used in all cases except when Standard or Sheathed Flat Cable is used at a baud rate of 93.75 kbits/s.

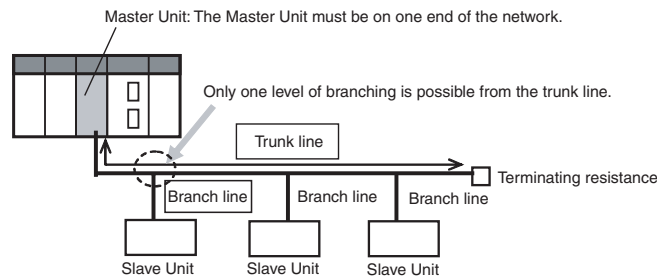

Unrestricted Wiring Formation

With this wiring formation, there is no differentiation between a trunk line and branch lines.

The Master Unit can be located anywhere in the network (not necessarily at the end) and there are no restrictions on branching. Repeater Units can be used.

An unrestricted wiring formation can be used only when Standard or Sheathed Flat Cable is used at a baud rate of 93.75 kbits/s.

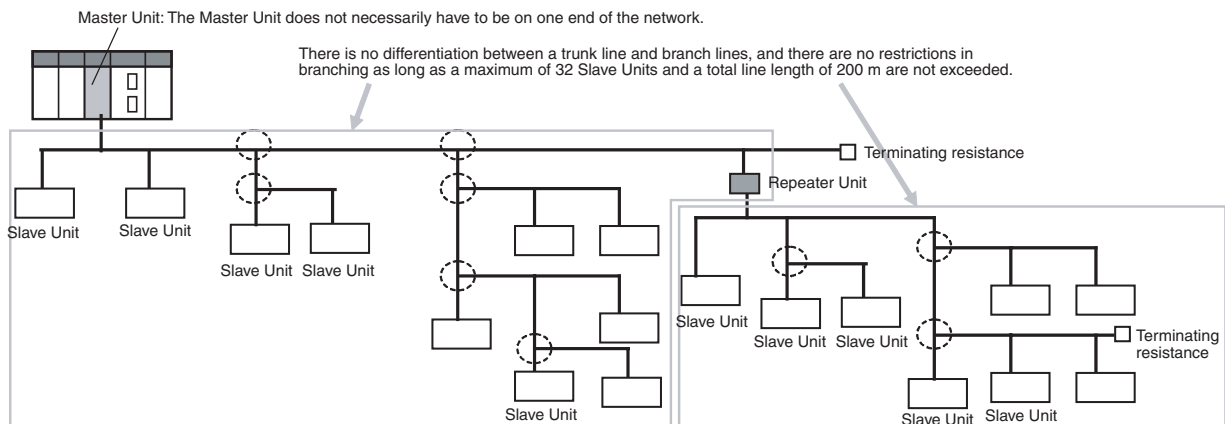

Wiring Formations

Item	Wiring formation	
	Trunk line-branch line formation	Unrestricted wiring formation
Overview	With this wiring formation, the trunk line is differentiated from branch lines. (There are also restrictions in branching from the trunk line.) Repeater Units can be used to create sub-trunk lines, which are equivalent to the trunk line.	With this wiring formation, there is no differentiation between the trunk line and branch lines. Wiring is unrestricted as long as the total cable length is 200 m or less.
Cable type and baud rate restrictions	VCTF cable at any baud rate, or Standard or Sheathed Flat Cable at any baud rate other than 93.75 kbits/s.	Standard or Sheathed Flat Cable at a baud rate of 93.75 kbits/s.
Master Unit location	End of network	Anywhere in network (not necessarily at the end)
Number of branch levels (between Master Unit or Repeater Unit and terminating resistance)	One branching level off of the trunk line or any one sub-trunk line	Any number of levels (no restriction)
Maximum number of Slave Units connected to any one branch line	1 or 3 depending on the cable type and baud rate	No restrictions
Terminating resistance location	On the most-remote (opposite) ends of the trunk line and all sub-trunk lines from the Master Unit and each Repeater Unit	On the most-remote ends of the network from the Master Unit and each Repeater Unit

3-2 CompoNet Network Wiring

3-2-1 CompoNet Network Wiring System

- There are two communications lines: BDH (communications data high) and BDL (communications data low).
- Communications between the Master Unit and Slave Units are possible merely by connecting the two communications lines in parallel to the Master Unit and Slave Units and then supplying communications power to the Slave Units.
- Wiring is performed with VCTF 2-conductor cable or Flat Cable (4-conductor).
 - VCTF 2-conductor cable provides the two communications lines.
 - Flat Cable (4-conductor) provides four lines: two communications line and two communications power lines.
- BS+ and BS- are used to provide communications power to the Slave Units (for communications and internal Slave Unit power). A 24-VDC power supply is used.
 - If VCTF 2-conductor cable is used, the power supply must be provided using separate lines.
 - If Flat Cable (4-conductor) is used, the BS+ and BS- lines in the Flat Cable are used to supply communications power.

■ Wiring Example Using VCTF 2-conductor Cable

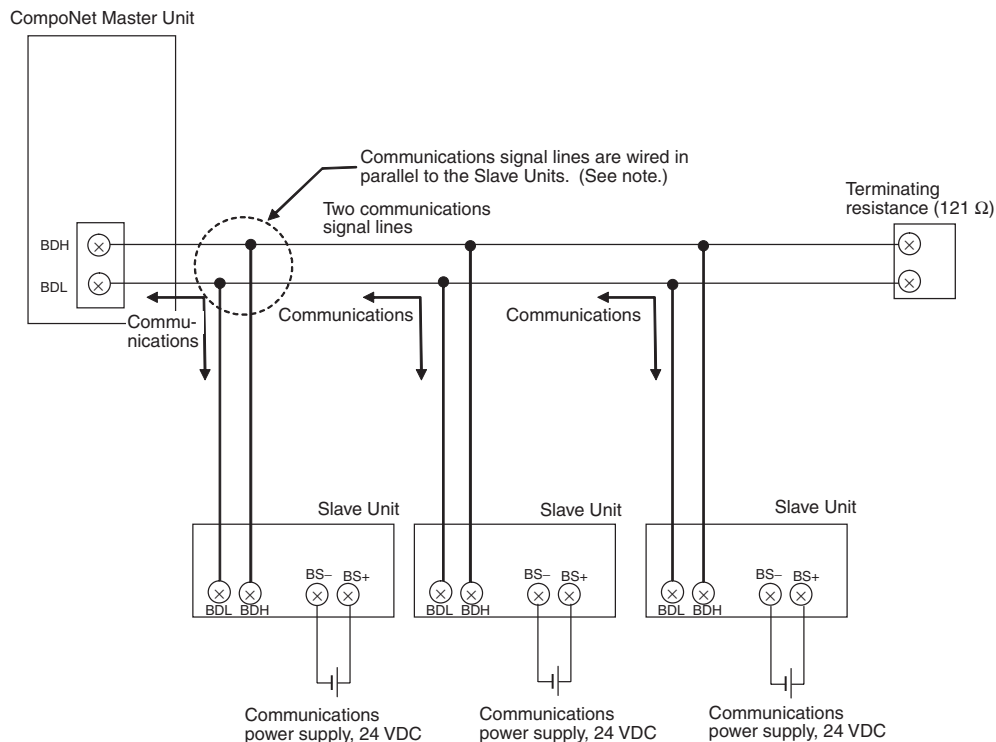

Note The parallel connections of the signal lines can be made with commercially available relay terminal blocks or multidrop connections.

■ Wiring Example Using Flat Cable (4-conductor)

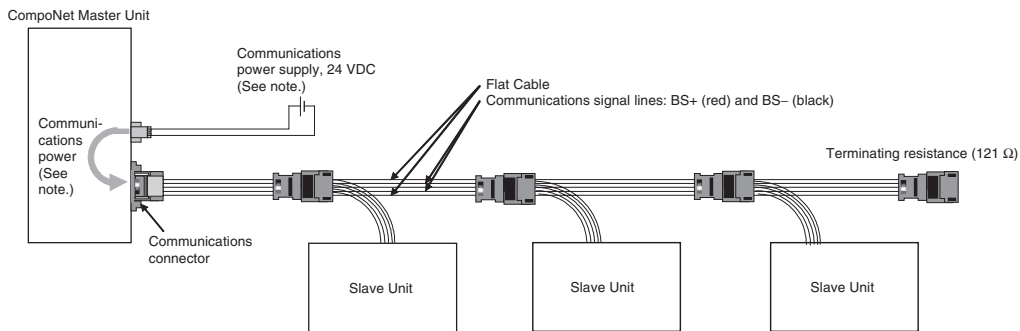

Note The communications power supply for the Slave Units is connected to the Master Unit or Repeater Unit and supply through the Flat Cable.

3-2-2 Cable Types

Cable Types

The three types of cable listed in the following table can be used as the communications cable for a CompoNet Network.

Do not use any other cables.

Cable type	Main application		Communica-tions power	Conductors				
				BDH (signal high)	BDL (signal low)	BS+ (com-munica-tions power supply posi-tive side)	BS- (com-munica-tions power supply neg-ative side)	
VCTF 2-conductor cable	<ul style="list-style-type: none"> • Wiring Slave Units between the Master Unit and Repeater Units • Wiring Slave Units down-stream from a Repeater Unit 	<ul style="list-style-type: none"> • When using commercially available cable is desirable. • To provide communications power separately. • When Bit Slave Units are not being used. 	Provided separately.	Black	White	None	None	
Standard Flat Cable			<ul style="list-style-type: none"> • To supply communications power to all Slave Units with the communications cable. • To use Bit Slave Units. 	Included	White	Blue	Red	Black
Sheathed Flat Cable			<ul style="list-style-type: none"> • To supply communications power to all Slave Units with the communications cable. • To use Bit Slave Units. • Applications in environments that required IP54 compliance (drip-proof, splash-proof). 	Included	White	Blue	Red	Black

VCTF 2-conductor Cable (Commercially Available)

Commercially available VCTF cable: 600-V vinyl-insulated cab-tyre cord) VCTF vinyl cord JIS C 3306, 2-conductor with nominal cross-section of 0.75 mm² (two signal lines), conductor resistance at 20°C: 25.1 Ω/km max.

DCA4-4F10 Standard Flat Cable (4-conductor)

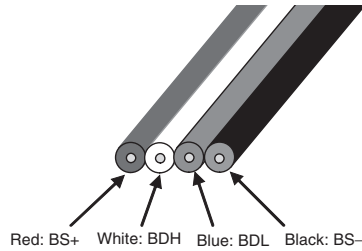

Model	Conductor No.	Insulation color	Application	Nominal cross-section	Conductor resistance (Ω/km)	Dielectric strength (V)	Insulation resistance ($\text{M}\Omega$)	Allowable current (A)
DCA3-4F10	1	Red	BS+ (communications power supply positive side)	AWG19	25.0 max.	2000	20 min.	5 max.
	2	White	BDH (signal high)	AWG21	37.5 max.			---
	3	Blue	BDL (signal low)	AWG21	37.5 max.			---
	4	Black	BS- (communications power supply negative side)	AWG19	25.0 max.			5 max.

DCA5-4F10 Sheathed Flat Cable (4-conductor)

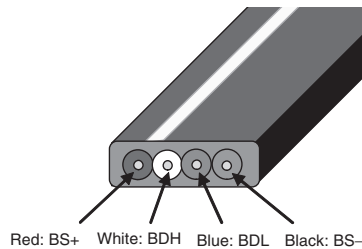

Model	Conductor No.	Insulation color	Application	Nominal cross-section	Conductor resistance (Ω/km)	Dielectric strength (V)	Insulation resistance ($\text{M}\Omega$)	Allowable current (A)
DCA4-4F10	1	Red	BS+ (communications power supply positive side)	AWG19	25.0 max.	2000	20 min.	5 max.
	2	White	BDH (signal high)	AWG21	37.5 max.			---
	3	Blue	BDL (signal low)	AWG21	37.5 max.			---
	4	Black	BS- (communications power supply negative side)	AWG19	25.0 max.			5 max.

Note The characteristics of each conductor in the Flat Cable has been adjusted to the application of the conductor. Check the line insulator colors and use each line only for the application given in the above table.

Using Different Cable Types

There are three types of cable: VCTF 2-core cable, Standard Flat Cable, and Sheathed Flat Cable.

The same type of cable must be used for all lines downstream from the Master Unit or from a Repeater Unit (i.e., the trunk line and branch lines, sub-trunk lines and their branch lines, and branch lines and sub-branch lines must use the same type of cable).

Different types of cable can be used upstream and downstream from a Repeater Unit, i.e., for a trunk line and sub-trunk line or for two different sub-trunk lines.

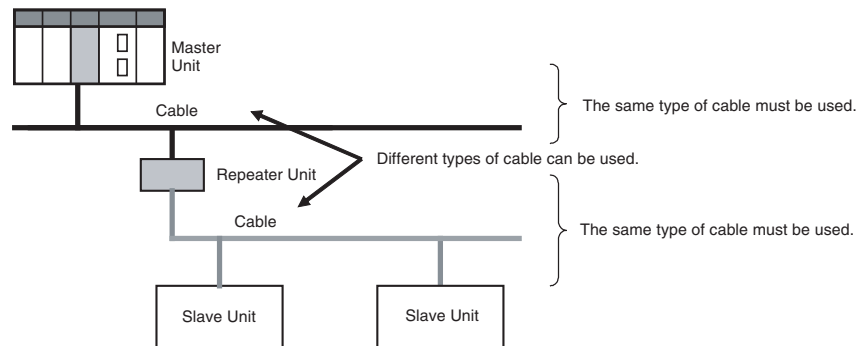

Note Standard Flat Cable and Sheathed Flat Cable are considered as different types of cable.

Cable Separation between Multiple CompoNet Network

When Standard or Sheathed Flat Cable is used in more than one CompoNet Network, the Cables must not be bundled together and must be separated by at least 5 mm to prevent unstable operation caused by interference.

Selecting Cable Types

Select the cable type using the following items as conditions.

Item		Cable type		
		VCTF 2-conductor cable	Standard Flat Cable	Sheathed Flat Cable
Application		Wiring Slave Units between the Master Unit and Repeater Units		
		Wiring Slave Units downstream from a Repeater Unit		
		<ul style="list-style-type: none"> When using commercially available cable is desirable. To provide communications power separately. When not using Bit Slave Units. 	<ul style="list-style-type: none"> To supply communications power to all Slave Units with the communications cable. To use IP20-type Bit Slave Units. 	<ul style="list-style-type: none"> To supply communications power to all Slave Units with the communications cable. To use IP54-type Bit Slave Units. Applications in environments that required IP54 compliance (drip-proof, splash-proof).
Applicable Slave Units	Word Slave Units	Supported	Supported	
	Bit Slave Units	IP20 Bit Slave Units	NA	Supported
		IP54 Bit Slave Units	<p>Note Bit Slave Units cannot be used with VCTF 2-conductor cable. Bit Slave Units are sold with Standard or Sheathed Flat Cable already connected.</p>	NA
Wiring method for communications power supply		Wired separately from the communications cable.	Same cable as communications cable. (Power is supplied from the Master Unit and Repeater Units.)	
Conditions for using different types of cable together		Different type of cable can be used upstream and downstream from a Repeater Unit (VCTF 2-conductor cable, Standard Flat Cable, Sheathed Flat Cable). In all other cases, the same type of cable must be used for the trunk line (or sub-trunk line) and all branch and sub-branch lines.)		
Master Unit location		End of trunk line	Baud rate other than 93.75 kbits/s: End of trunk line 93.75 kbits/s: Anywhere in network	
Branch lines		4 Mbits/s: NA Baud rates other than 4 Mbits/s: Supported	4 Mbits/s: NA Baud rates other than 4 Mbits/s: Supported 93.75 kbits/s: Unrestricted branching	

Item		Cable type		
		VCTF 2-conductor cable	Standard Flat Cable	Sheathed Flat Cable
Multi-connections on branch lines	Multidrop connections on branch lines	3 Mbits/s, 1.5 Mbits/s, or 93.75 kbits/s: Supported (3 multidrop connections per branch)	3 Mbits/s or 1.5 Mbits/s: Supported (3 multidrop connections per branch) 93.75 kbits/s: Unrestricted branching	NA
	Sub-branch lines	NA	1.5 Mbits/s: Supported (3 per branch) 93.75 kbits/s: Unrestricted branching	
Communications distance	4 Mbits/s	Trunk line/sub-trunk line: 30 m max.	Trunk line/sub-trunk line: 30 m max.	
	3 Mbits/s	Trunk line/sub-trunk line: 30 m max.	Trunk line/sub-trunk line: 30 m max.	
	1.5 Mbits/s	Trunk line/sub-trunk line: 100 m max. without branches, 30 m max. with branches	Trunk line/sub-trunk line: 30 m max.	
	93.75 kbits/s	Trunk line/sub-trunk line: 500 m max.	Total wiring length: 200 m max.	

3-2-3 Connection Methods

VCTF 2-conductor Cable

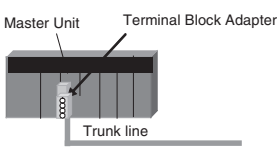
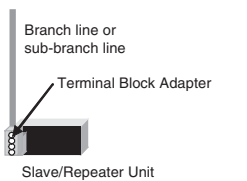
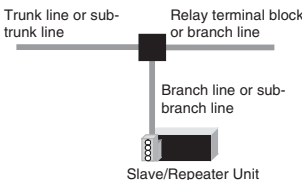
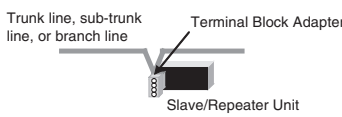
Master Unit connections	Slave Unit/Repeater Unit connections	Cable branches	
		T-branch connections	Multidrop connections
Terminal Block Adapter 		Commercially available relay terminal block 	Terminal Block Adapter 

Flat Cable

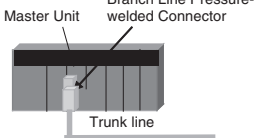
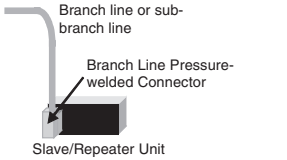
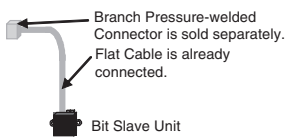
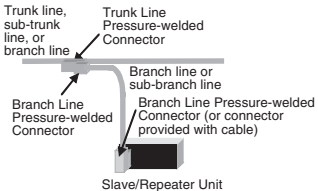
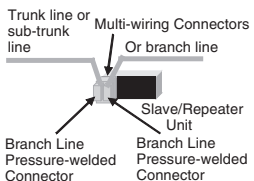
Master Unit connections	Slave Unit/Repeater Unit connections	Cable branches	
		T-branch connections	Multidrop connections
Branch Line Pressure-welded Connector 	 <p>Note Bit Slave Units are sold with Flat Cables already connected to them.</p> 	Trunk/Branch Line Pressure-welded Connector 	Multi-wiring Connector  <p>Note Multidrop connections using Multi-wiring Connectors is not possible for Sheathed Flat Cable.</p>

3-2-4 Node Connection Methods

Nodes are connected to the CompoNet Network using the methods described in this section.

Master Unit Connections

Except in unrestricted wiring formations, the Master Unit must always be connected on one end of the trunk line.

The Master Unit has a communications connector to which a communications cable is connected.

Connecting Flat Cable with a Branch Line Pressure-welded Connector

The following Branch Line Pressure-welded Connectors are used to connect Flat Cable to the Master Unit.

Standard Flat Cable or VCTF 2-conductor Cable

A DCN4-BR4 Standard Flat Cable Branch Line Pressure-welded Connector is used.

Sheathed Flat Cable

A DCN5-BR4 Sheathed Flat Cable Branch Line Pressure-welded Connector is used.

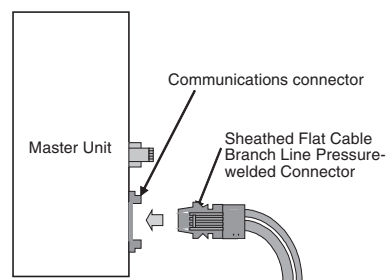
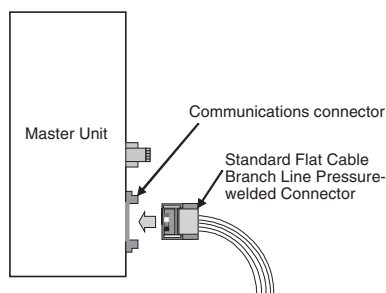

Connecting VCTF 2-conductor Cable with a Terminal Block Adapter

The following Terminal Block Adapter is used to connect VCTF 2-conductor cable to the Master Unit.

The Terminal Block Adapter is used to convert the communications connector on the Master Unit to a terminal block. The Terminal Block Adapter takes M3 crimp terminals.

VCTF 2-conductor Cable

A DCN4-TB4 Terminal Block Adapter is used.

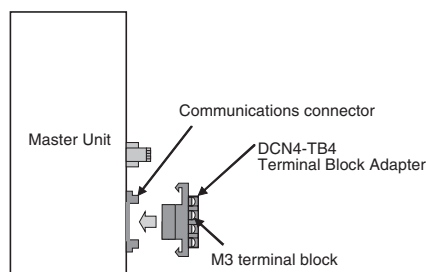

Slave Unit and Repeater Unit Connections

The Slave Units and Repeater Units have a communications connector to which a communications cable is connected.

Connecting Flat Cable with a Branch Line Pressure-welded Connector

The following Branch Line Pressure-welded Connectors are used to connect Flat Cable to a Slave Unit or Repeater Unit.

Standard Flat Cable or VCTF 2-conductor Cable

A DCN4-BR4 Standard Flat Cable Branch Line Pressure-welded Connector is used.

Sheathed Flat Cable

A DCN5-BR4 Sheathed Flat Cable Branch Line Pressure-welded Connector is used.

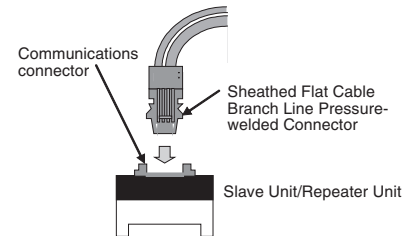
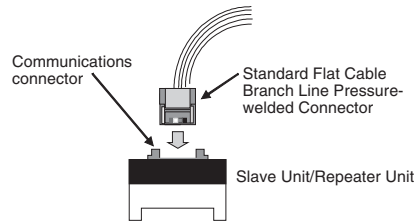

Connecting VCTF 2-conductor Cable with a Terminal Block Adapter

The following Terminal Block Adapter is used to connect VCTF 2-conductor cable to a Slave Unit or Repeater Unit.

The Terminal Block Adapter is used to convert the communications connector on the Slave Unit or Repeater Unit to a terminal block. The Terminal Block Adapter takes M3 crimp terminals.

VCTF 2-conductor Cable

A DCN4-TB4 Terminal Block Adapter is used.

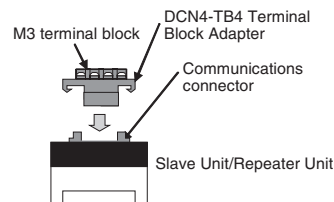

3-2-5 Cable Branches

There are two methods that can be used to branch the trunk line, sub-trunk lines, and branch lines: T-branches and multidrop connections.

T-branches

Connecting Flat Cable with Trunk Line and Branch Line Pressure-welded Connectors

A T-branch is made using special pressure-welded connectors (Trunk Line Pressure-welded Connector and Branch Line Pressure-welded Connector).

■ Standard Flat Cable

A DCN4-TR4 Standard Flat Cable Trunk Line Pressure-welded Connector and DCN4-BR4 Standard Flat Cable Branch Line Pressure-welded Connector are used.

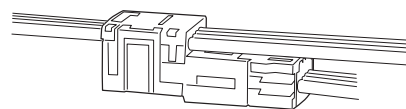
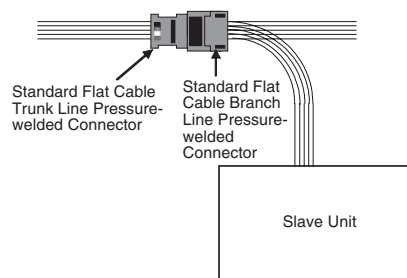

■ Sheathed Flat Cable

A DCN5-TR4 Sheathed Flat Cable Trunk Line Pressure-welded Connector and DCN5-BR4 Sheathed Flat Cable Branch Line Pressure-welded Connector are used.

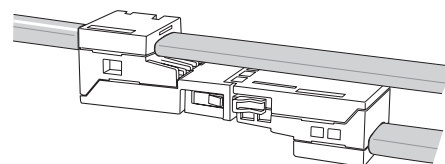
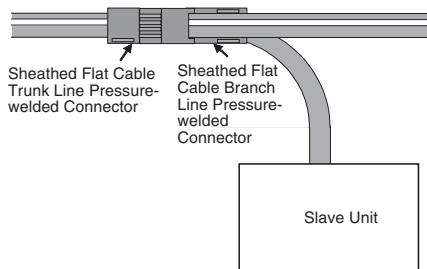

Note The same type of cable must be used for the trunk line and branch line.

Connecting VCTF 2-conductor Cable with a Commercially Available Relay Terminal Block

A T-branch is made using a commercially available relay terminal block.

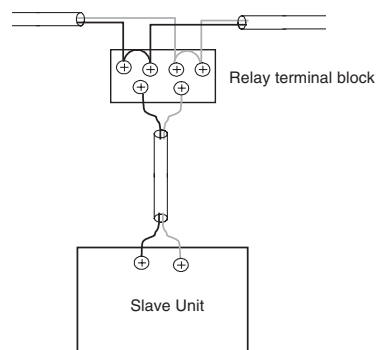

Multidrop Connections

Connecting Flat Cable with a Multi-wiring Connector

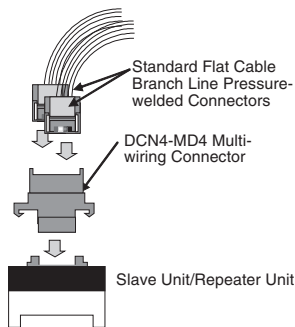

Connecting VCTF 2-conductor Cable with a Terminal Block Adapter

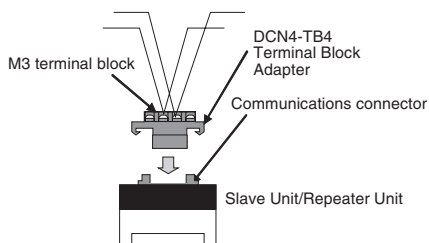

3-2-6 Extending the Cable Length

The cable length for the trunk line, sub-trunk lines, branch lines, and sub-branch lines can be extended by combining a Trunk Line Pressure-welded Connector with a Branch Line Pressure-welded Connector.

When this method is used, up to 10 sets of Trunk Line and Branch Line Pressure-welded Connectors can be used. The maximum extendable length, however, is the standard maximum trunk line length.

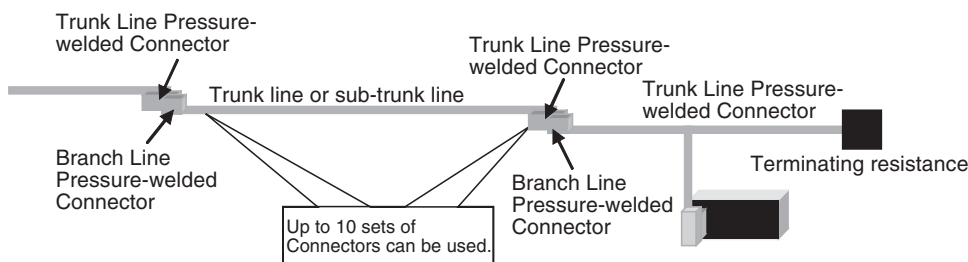

■ Standard Flat Cable

A DCN4-TR4 Standard Flat Cable Trunk Line Pressure-welded Connector with a cable stopper and a DCN4-BR4 Standard Flat Cable Branch Line Pressure-welded Connector are used.

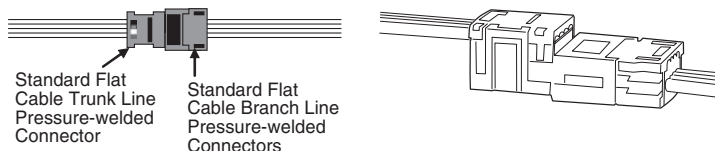

■ Sheathed Flat Cable

A DCN5-TR4 Sheathed Flat Cable Trunk Line Pressure-welded Connector with an internal stopper and a DCN5-BR4 Sheathed Flat Cable Branch Line Pressure-welded Connector are used.

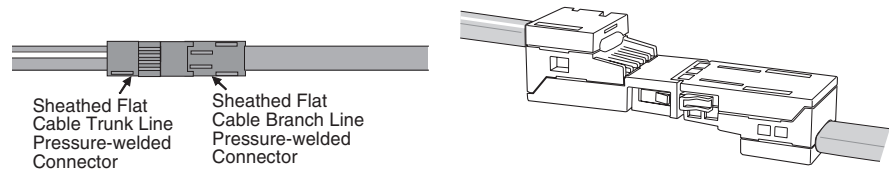

3-2-7 Connection Locations for Terminating Resistance

Terminating resistance must always be connected to the trunk line and each sub-trunk line on the opposite end from the Master Unit or Repeater Unit.

Note Do not connect terminating resistance on the end of the Network with the Master Unit.

When the trunk line or sub-trunk line is branched, the terminating resistance is connected to the end of the branch line farthest from the Master Unit or Repeater Unit.

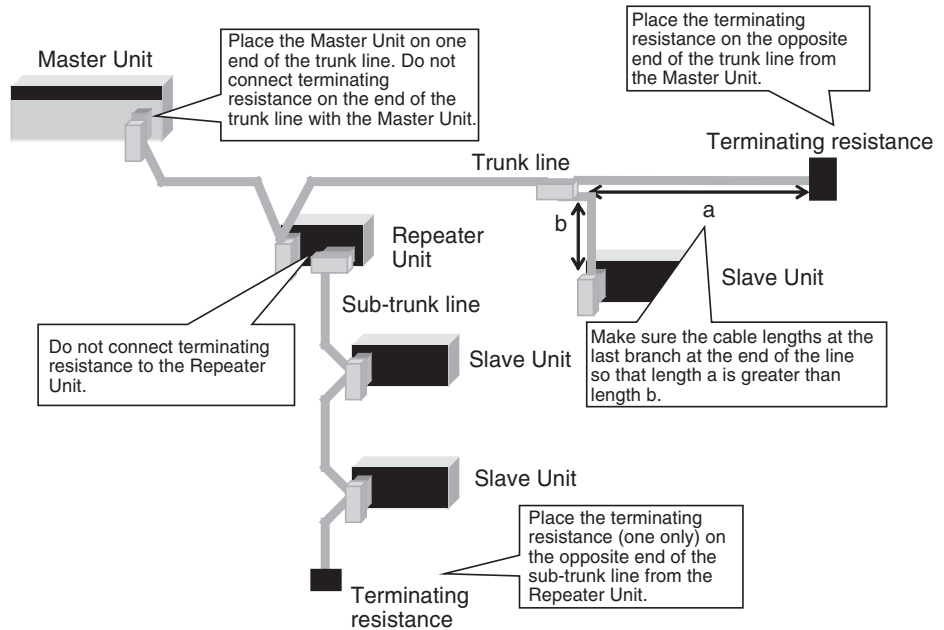

Connecting Terminating Resistance

There are three methods that can be used to connect terminating resistance.

Method 1:

Connect a Trunk Line Pressure-welded Connector to the trunk line or sub-trunk line and then connect a Terminating Resistor to the Connector.

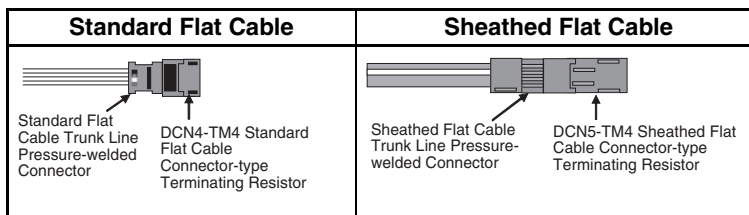

Method 2:

Connect a Multi-wiring Connector to the communications connector for the upstream port on the Slave Unit or Repeater Unit and then connect the trunk line cable and a Connector-type Terminating Resistor to the Multi-wiring Connector.

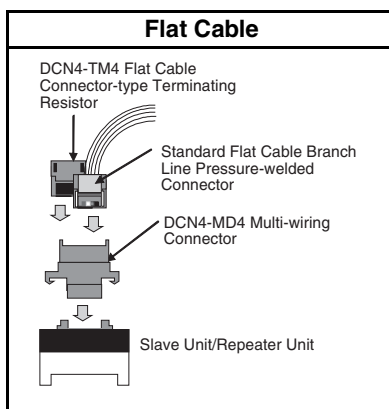

Method 3:

Connect a Terminal Block-type Terminating Resistor to the trunk line or sub-trunk line cable.

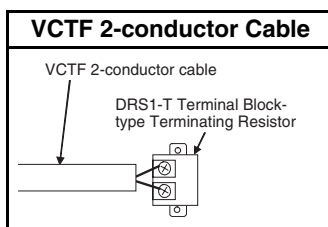

Models and Characteristics of Terminating Resistors

There are two types of Terminating Resistor: the Connector-type and the Terminal Block-type.

Type of Terminating Resistor	Connector-type		Terminal Block-type
Name	Standard Flat Cable Connector-type Terminating Resistor	Sheathed Flat Cable Connector-type Terminating Resistor	Terminal Block-type Terminating Resistor
Model	DCN4-TM4	DCN5-TM4	DRS1-T
Resistance	121 Ω	121 Ω	121 Ω
Rated power	1/4 W	1/4 W	1/4 W

Type of Terminating Resistor	Connector-type		Terminal Block-type
Accuracy	1% max.	1% max.	---
Power handling capacity	0.01 μ F	0.01 μ F	---
Applicable cable	Standard Flat Cable	Sheathed Flat Cable	VCTF 2-conductor cable

3-2-8 Connection Locations for Communications Power Supply

Connect the communications power supply as shown in the following diagrams.

Flat Cable

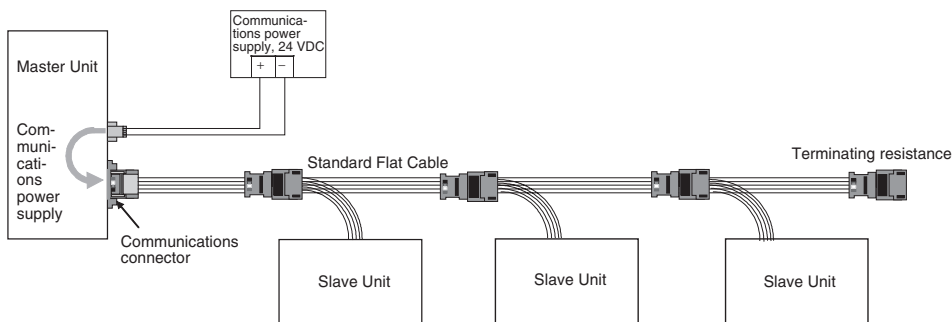

The communications power supply (BS+ and BS-) is connected to the communications power supply connector on the Master Unit. Doing so will supply communications power to the Slave Units on the trunk line from the Flat Cable.

- Note**
- (1) Connect the communications power supply at only one location for the trunk line and each sub-trunk line.
 - (2) Connect the communications power supply to the downstream port communications power supply connector on the Repeater Unit to supply power to a sub-trunk line.

VCTF 2-conductor Cable

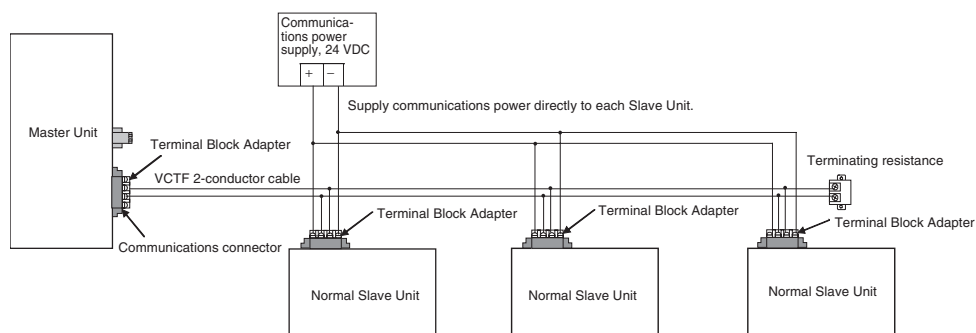

The communications power supply (BS+ and BS-) is connected separately to each Slave Unit and Repeater Unit (see note). Power does not need to be supplied to the Master Unit.

Note The communications power to the Repeater Unit must be supplied to the BS+ and BS- terminals on the upstream port (port 1).

Refer to 4-4 Power Supply Wiring for details on wiring the communications power supply.

SECTION 4

Installation and Wiring

This section describes how to install and wire a CompoNet Network.

4-1	Installation	66
4-1-1	Tools Required for Installation and Wiring	66
4-1-2	Installation Locations According to Degree of Protection	66
4-1-3	Installing the Master Unit	68
4-1-4	Installing Slave Units	70
4-2	Connecting Cables	74
4-2-1	Overview	74
4-2-2	Connecting to Units	76
4-2-3	Branching Lines	80
4-2-4	Extending Lines	82
4-2-5	Connecting Terminating Resistance	82
4-3	Preparing Pressure-welded Connectors	84
4-3-1	Tools Required for Installation and Wiring	84
4-3-2	Standard Flat Cables	84
4-3-3	Sheathed Flat Cable	90
4-4	Power Supply Wiring	95
4-4-1	Supplying Power to Slave Units	96
4-4-2	Connecting the Communications Power Supply	97
4-4-3	Communications Power Supply Specifications	98
4-4-4	Current Consumption	99
4-4-5	Communications Power Supply Wiring Examples	101
4-4-6	Precaution in Supplying Power to Slave Units	108
4-4-7	Precautions on Locating the I/O Power Supply	109
4-4-8	Other Precautions	110
4-5	Connecting External I/O for Slave Units	110
4-5-1	Word Slave Units (CRT1-ID16(-1) and CRT1-OD16(-1))	110
4-5-2	Bit Slave Units	111

4-1 Installation

- Note**
- (1) A sheet is attached to the Master Unit to prevent pieces of wire from entering it. Install and wire the Master Unit with this sheet in place. Stray strands of wire could cause malfunctions.
 - (2) Be sure to remove the sheet after installation and wiring to facilitate cooling. The Master Unit could overheat and malfunction if the sheet is not removed.

4-1-1 Tools Required for Installation and Wiring

The following tools are required to install, wire, and set the Units.

- Phillips screwdrivers: M3 and M4: To install and wire I/O for the Master Unit, Slave Units, and Repeater Units.
- Precision screwdriver: To set rotary switches and DIP switches.

4-1-2 Installation Locations According to Degree of Protection

The degree of protection of the CompoNet Network Units depends on the model of the Unit. The degree of protection for each Unit is given in the following table. Select suitable installation locations accordingly.

Master Units, Slave Units, and Repeater Units

Name	Model	Degree of protection	Applicable peripheral devices
Master Units	CS1W-CRM21	---	Standard Flat Cable peripheral devices, Sheathed Flat Cable peripheral devices, and VCTF 2-conductor cable
	CJ1W-CRM21		
Digital I/O Slave Units	CRT1-ID16	---	
	CRT1-ID16-1		
	CRT1-OD16		
	CRT1-OD16-1		
IP20 Bit Slave Units	CRT1B-ID02S	IP20	
	CRT1B-ID02S-1		
	CRT1B-OD02S		
	CRT1B-OD02S-1		
IP54 Bit Slave Units	CRT1B-ID02SP	IP54	
	CRT1B-ID02SP-1		
	CRT1B-OD02SP		
	CRT1B-OD02SP-1		
	CRT1B-ID04SP		
	CRT1B-ID04SP-1		
	CRT1B-MD04SLP		
	CRT1B-MD04SLP-1		
Analog I/O Slave Units	CRT1-AD04	---	
	CRT1-DA02		
Repeater Unit	CRS1-RPT01	---	

Standard Flat Cable Peripheral Devices

Name	Model	Degree of protection	Applicable peripheral devices
Standard Flat Cable	DCA4-4F10	---	Standard Flat Cable (100 m)
Standard Flat Cable Trunk Line Pressure-welded Connector	DCN4-TR4	IP40	Only for Standard Flat Cable
Standard Flat Cable Branch Line Pressure-welded Connector	DCN4-BR4	IP40	Only for Standard Flat Cable
Standard Flat Cable Connector-type Terminating Resistor	DCN4-TM4	IP40	Only for Standard Flat Cable

Sheathed Flat Cable Peripheral Devices

Name	Model	Degree of protection	Applicable peripheral devices
Sheathed Flat Cable	DCA5-4F10	---	Sheathed Flat Cable (100 m)
Sheathed Flat Cable Trunk Line Pressure-welded Connector	DCN5-TR4	IP54	Only for Sheathed Flat Cable
Sheathed Flat Cable Branch Line Pressure-welded Connector	DCN5-BR4	IP54	Only for Sheathed Flat Cable
Sheathed Flat Cable Connector-type Terminating Resistor	DCN5-TM4	IP54	Only for Sheathed Flat Cable

4-1-3 Installing the Master Unit

The Master Unit is installed and used as part of the PLC. The installation method on the PLC is the same as for any normal Unit.

System Configuration Precautions

- For a CS-series PLC, the Master Unit can be mounted to a CPU Backplane (CS1W-BC□□□□) or an Expansion Backplane (CS1W-BI□□□□). Up to 80 Units can be mounted for any one PLC.
- For a CJ-series PLC, the Master Unit can be connected in the CPU Rack or an Expansion Rack (10 Units per Rack). Up to 40 Units can be mounted for any one PLC.

Installing the Master Unit

CS-series Master Unit

Use the following procedure to install the CS-series Master Unit.

- 1,2,3...
1. Mount the Unit to the Backplane by attaching it with the top and bottom hooks.

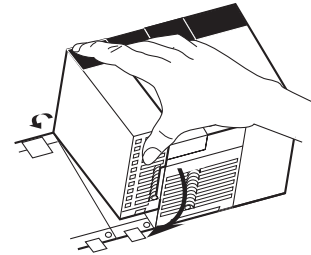
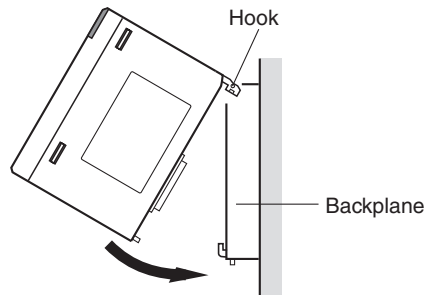

2. Properly insert the Unit into the Backplane connector.
3. Tighten the screen on the bottom of the Unit with a Phillips screwdriver. The screwdriver must be held at a slight angle to tighten the screw; be sure to leave sufficient space below the Backplane.

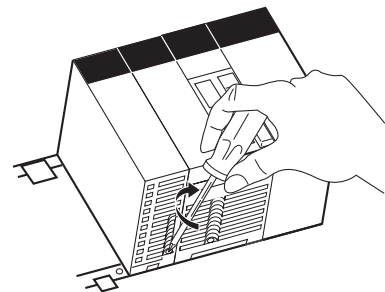
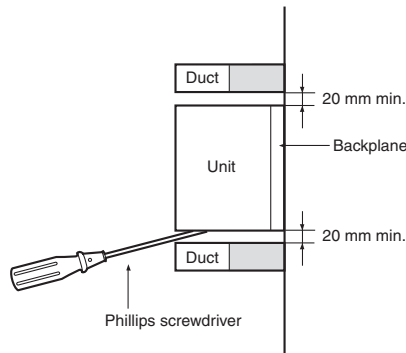

Note Tighten the screen on the bottom of the Unit to a torque of 0.4 N·m.

To remove the Unit, loosen the screw at the bottom with a Phillips screwdriver, lift up on the bottom of the Unit, and remove the Unit.

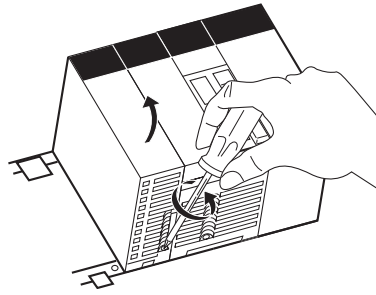

CJ-series Master Unit

- 1,2,3... 1. Align the connectors and connect the Master Unit.

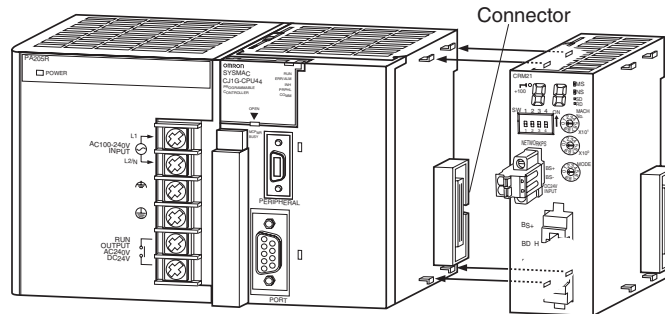

2. Slide the yellow sliders at the top and bottom of the Unit until they click into place and lock the Unit.

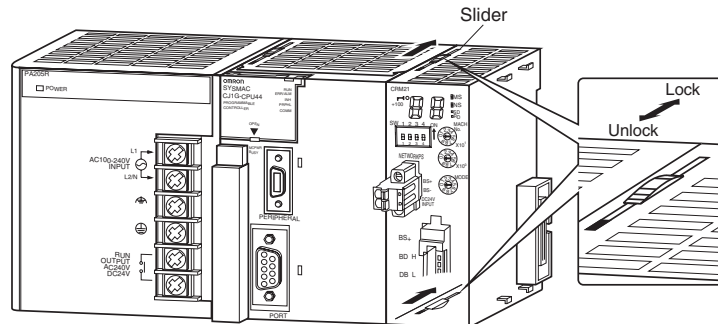

Note If the sliders are not locked completely, the Master Unit may not function properly.

To remove the Unit, unlock the sliders and remove the Unit.

Unit Handling Precautions

- Always turn OFF the power supply to the PLC before performing any wiring operations on the Unit.
- To prevent noise from affecting the system, place all wires connected to the Unit ports in ducts, and use separate ducts from those used for high-voltage and high-power lines.
- Wire with the sheets on top of the Units in place to prevent pieces of wire from entering the Unit. Remove the sheets after completing wiring to facilitate cooling.

Slave Unit Installation and Wiring Methods

Name	Model	Installation method	I/O wiring method	Internal power	External power
Basic Digital I/O Slave Units (transistor-type)	CRT1-ID16(-1)	DIN Track	M3 terminal block	Supplied along with communications power	An external power supply is required for I/O.
	CRT1-OD16(-1)				
Expansion Digital I/O Slave Units (transistor-type)	XWT-ID16(-1)				
	XWT-OD16(-1)				
	XWT-ID08(-1)				
	XWT-OD08(-1)				
Bit Slave Units (transistor-type)	CRT1B-ID02(-1)	Screw installation (M4)	Industrial standard sensor connector (e-CON)	Supplied along with communications power	
	CRT1B-OD02(-1)				
	CRT1B-ID02SP(-1)				
	CRT1B-OD02SP(-1)	Screw-less terminal block			
	CRT1B-ID04SP(-1)				
	CRT1B-MD04SLP(-1)				
Analog I/O Slave Units	CRT1-AD04	DIN Track	M3 terminal block	An external power supply is required for I/O.	
	CRT1-DA02				
Repeater Unit	CRS1-RPT01	DIN Track or Screw installation (M4)	---	Communications power for the sub-trunk line must be supplied from the power supply connector.	

Note Supply I/O power to Expansion Slave Units according to the following table.

Combination	I/O power supply to Expansion Slave Unit
Basic Input Unit with Expansion Input Unit Example: CRT1-ID16 + XWT-ID16	Not required (Expansion Slave Unit uses the same I/O power supply as the Basic Slave Unit.)
Basic Input Unit with Expansion Output Unit Example: CRT1-ID16 + XWT-OD16	Required (I/O power must be supplied to both Units.)
Basic Output Unit with Expansion Input Unit Example: CRT1-OD16 + XWT-ID16	Required (I/O power must be supplied to both Units.)
Basic Output Unit with Expansion Output Unit Example: CRT1-OD16 + XWT-OD16	Required (I/O power must be supplied to both Units.)

Installation

Word Slave Units

Word Slave Units CRT1-ID16(-1), CRT1-OD16(-1), CRT1-AD04, and CRT1-DA02) can be installed on the control panel using the following method.

- DIN Track

Note Installation with screws is not possible.

Repeater Units

The Repeater Unit (CRS1-RPT01) can be installed on the control panel using the following methods.

- Screw installation
- DIN Track

Bit Slave Units

Bit Slave Units (CRT1B-□D0□S□□(-1)) can be installed on the control panel using the following method.

- Screw installation

Note Installation on DIN Track is not possible.

Installation on DIN Track (Word Slave Units and Repeater Units)

Connect the back of Word Slave Units and Repeater Units to 35-mm DIN Track. Pull down the DIN Track mounting pin on the back of the Slave Unit or Repeater Unit and be sure that the DIN Track is securely and completely inserted into the back of the Slave Unit or Repeater Unit. The Slave Unit or Repeater Unit can be mounted to the DIN Track without pulling down the mounting pin, but be sure that the Slave Unit or Repeater Unit is mounted securely either way.

Connect an End Plate on both sides on the Slave Unit or Repeater Unit.

Note Always secure the Slave Unit or Repeater Unit by mounting an End Plate on both sides.

Materials Required for Installation

The following are required when installing a Slave Unit or Repeater Unit to DIN Track. Screws are not required to secure the Slave Unit or Repeater Unit to the control panel in this case.

Name	Model	Length	Remarks
35-mm DIN Track	PFP-50N	50 cm	
	PFP-100N	100 cm	
	PFP-100N2	100 cm	
End Plate	PFP-M	---	Two End Plates are required for each Slave Unit and each Repeater Unit.

Installing Bit Slave Units and Repeater Units to the Control Panel with Screws

Refer to the dimensions for the Bit Slave Unit or Repeater Unit, prepare mounting holes on the control panel, and use the specified size of screws and tightening torque to mount a Bit Slave Unit or Repeater Unit to the control panel.

- M4 screws, 0.9 N·m

Installing Bit Slave Units (CRT1B-ID02S(-1) and CRT1B-OD02S(-1))

This section describes specific installation methods. The CRT1B-ID02S(-1) and CRT1B-OD02S(-1) are installed using the enclosed screw bracket along with screw holes in one of two orientations.

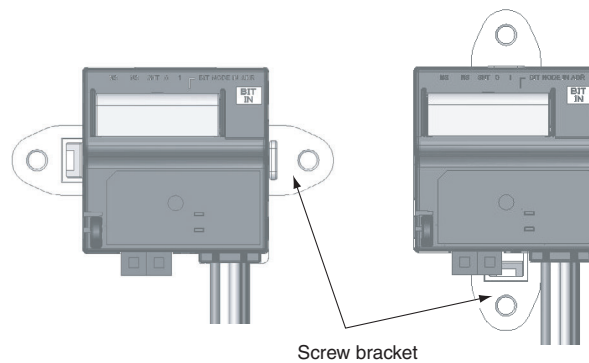

Attaching the Screw Bracket

- 1,2,3... 1. Insert the screw bracket into the back of the Unit along the guides.

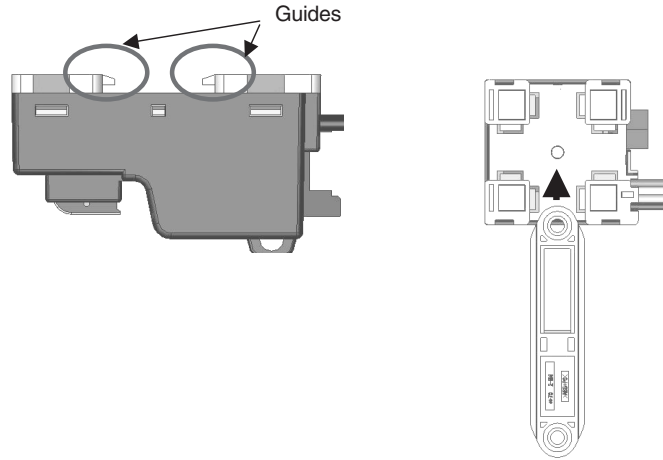

2. Press the screw bracket in until the hooks on the bracket are completely locked into place.

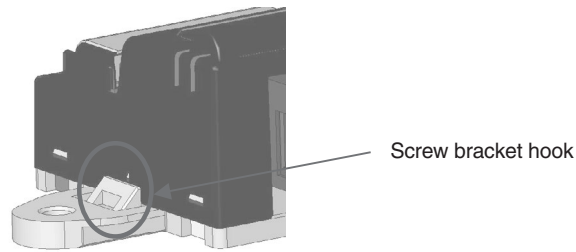

Installation Orientation

There are no restrictions in the orientation unless otherwise specified in Slave Unit instructions. Installation is possible in any of the following orientations.

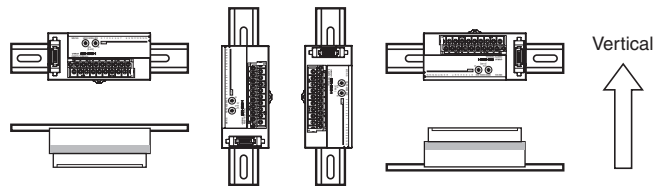

4-2 Connecting Cables

4-2-1 Overview

This section provides an outline of connecting a CompoNet Network using Flat Cables and VCTF 2-conductor cables.

Refer to *SECTION 3 Wiring Configurations* for information on the configuration.

Refer to *4-4 Power Supply Wiring* for information on supplying communications power.

Example Using Flat Cable

T-branches Connection

Note T-branches can be used together with multidrop connections.

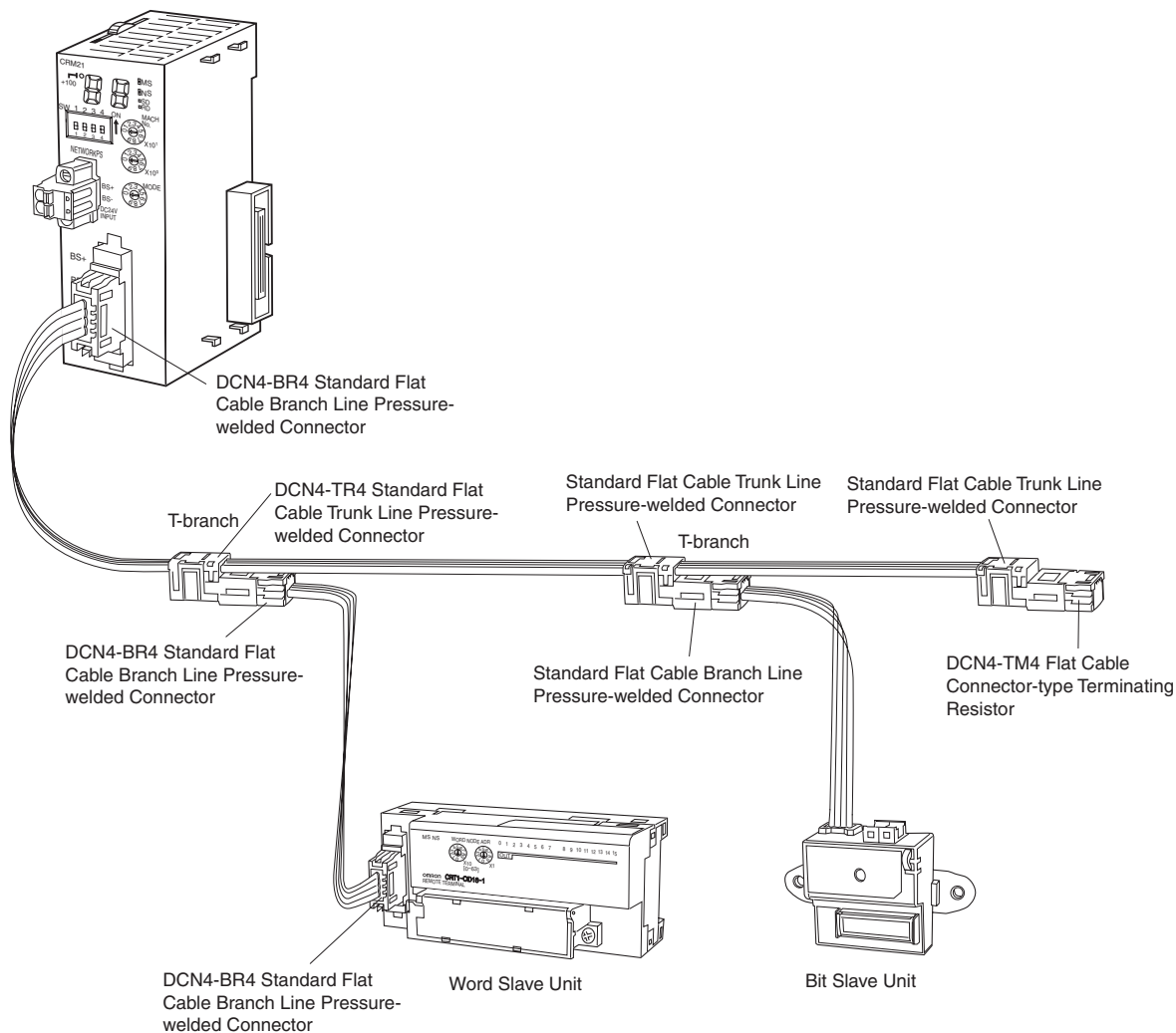

Multidrop Connections

Note Multidrop connections can be used together with T-branches.

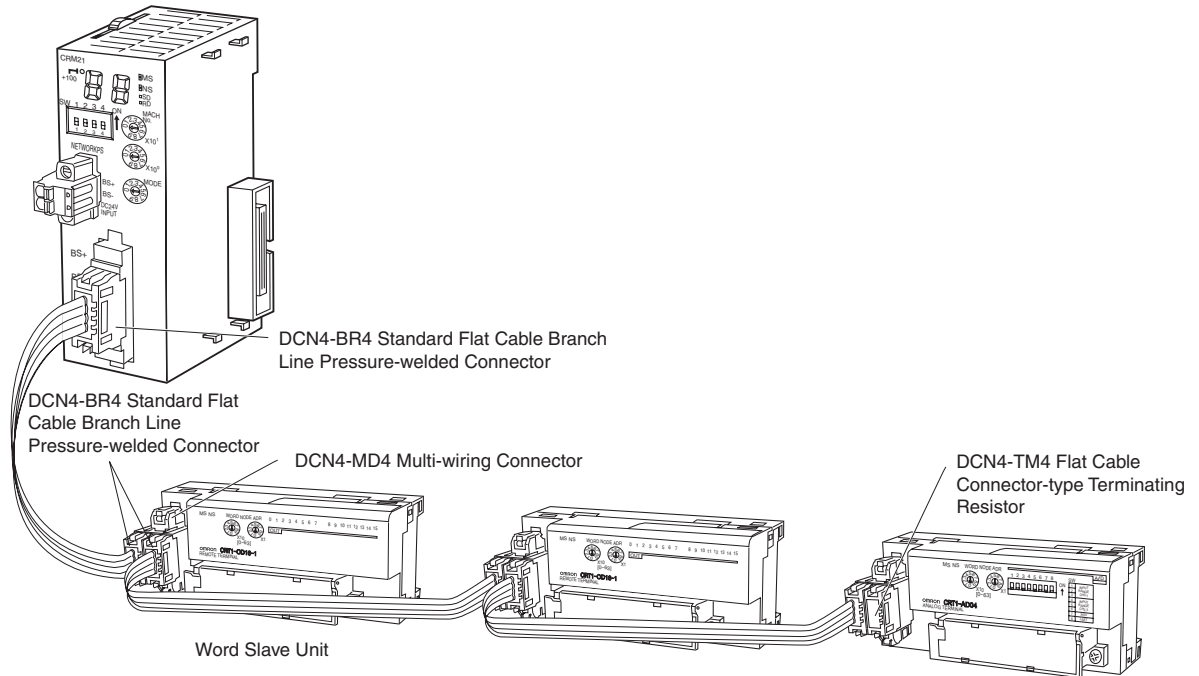

Example Using VCTF 2-conductor Cable

Note T-branches can also be made using commercially available relay terminal blocks.

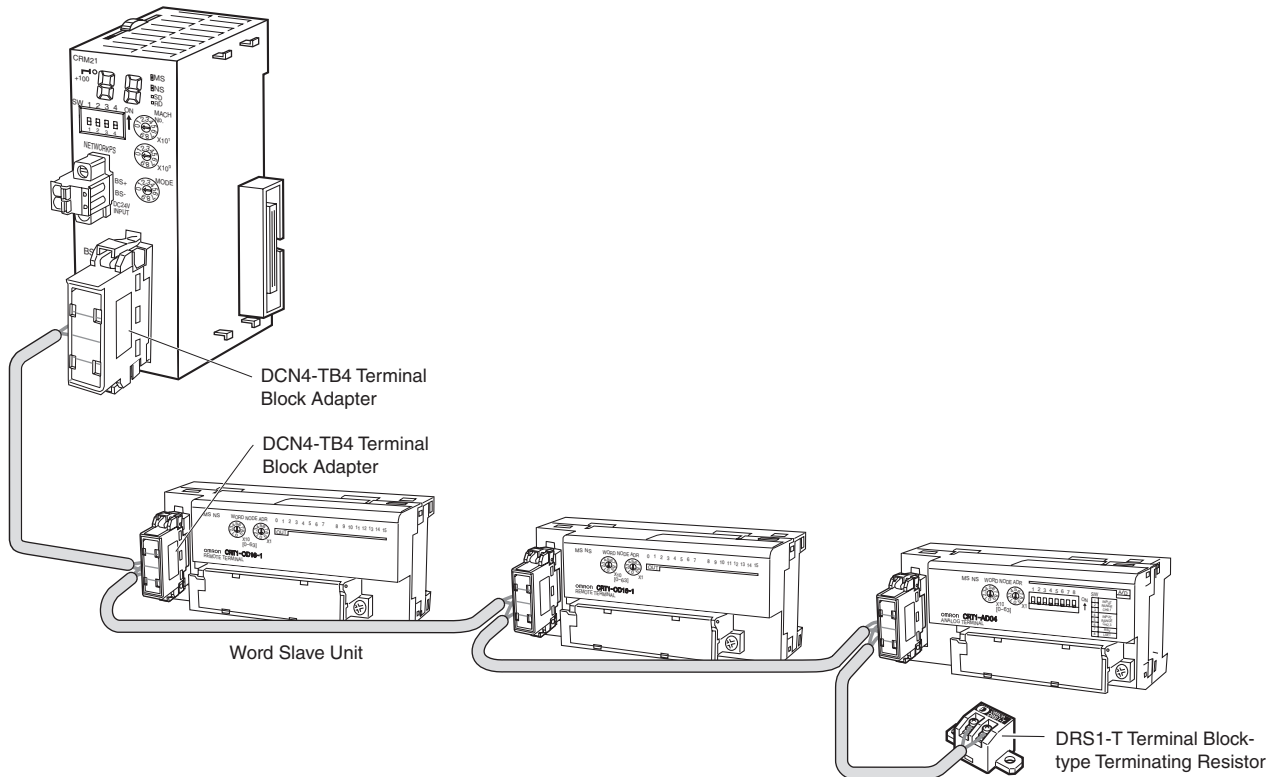

4-2-2 Connecting to Units

Connecting the Trunk Line to the Master Unit

Standard Flat Cable

A DCN4-BR4 Standard Flat Cable Branch Line Pressure-welded Connector is connected to the communications connector on the Master Unit.

Refer to 4-3 *Preparing Pressure-welded Connectors* for information on attaching a cable to the Connector.

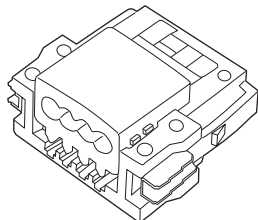

Be sure the face of the Connector on which line colors are indicated (red, white, blue, and black) is facing to the left and press in the Connector until it clicks into place.

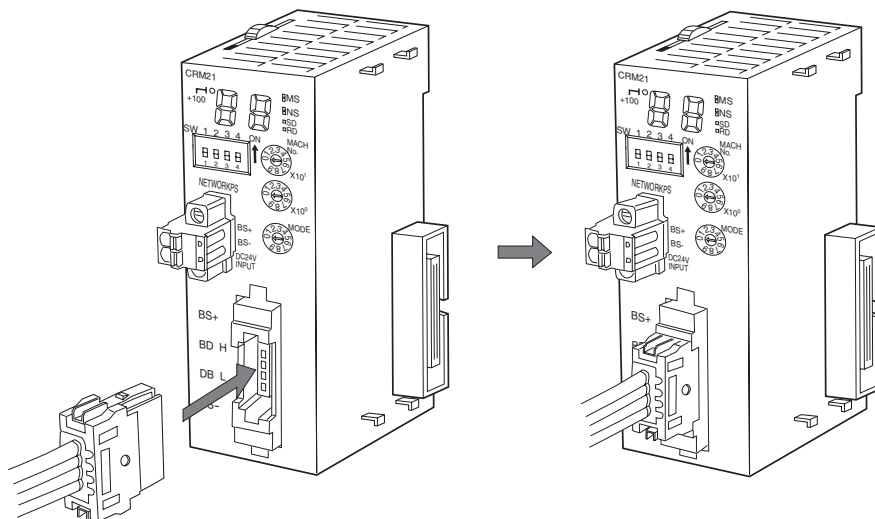

Note To remove a Connector once it has been attached, press in on the catches on both sides and pull out the Connector.

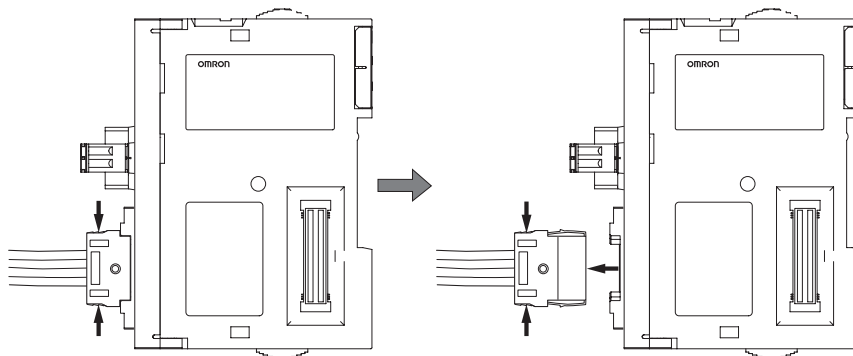

Sheathed Flat Cable

A DCN4-BR5 Sheathed Flat Cable Branch Line Pressure-welded Connector is connected to the communications connector on the Master Unit.

Refer to 4-3 *Preparing Pressure-welded Connectors* for information on attaching a cable to the Connector.

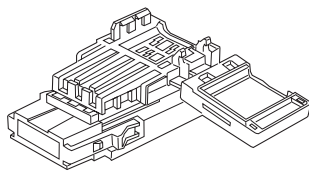

Orient the Connector so that the white line on the cable is facing to the left and press in the Connector until it clicks into place.

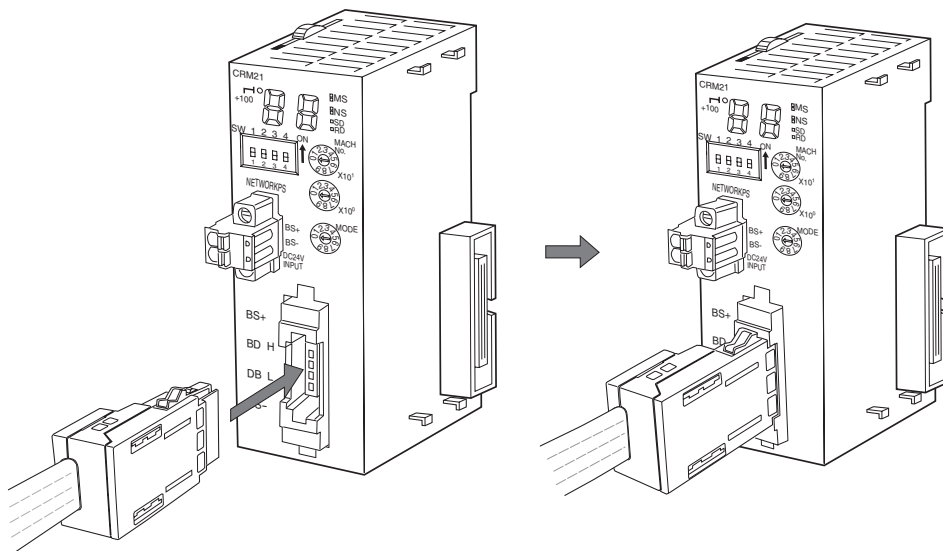

Note To remove a Connector once it has been attached, press in firmly on the catches on both sides of the front of the Connector and pull out the Connector.

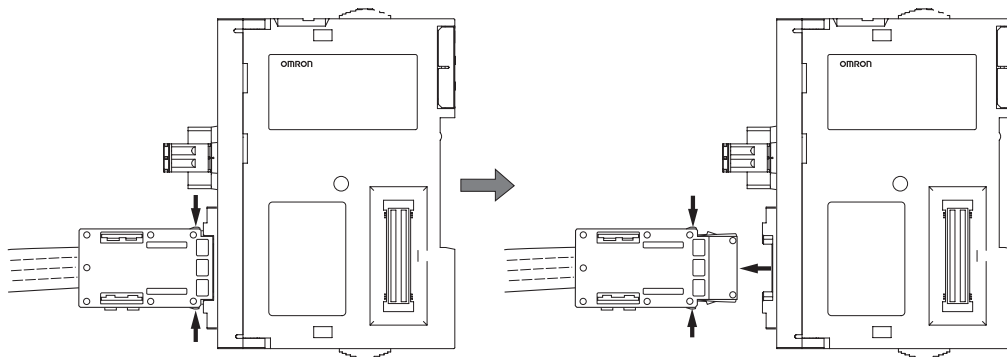

VCTF 2-conductor Cable

A DCN4-TB4 Terminal Block Adapter is used.

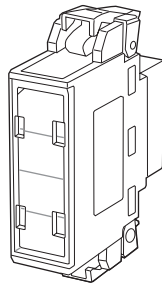

Orient the Adapter so that surface with the open terminals is facing to the left and press in the Adapter until it clicks into place.

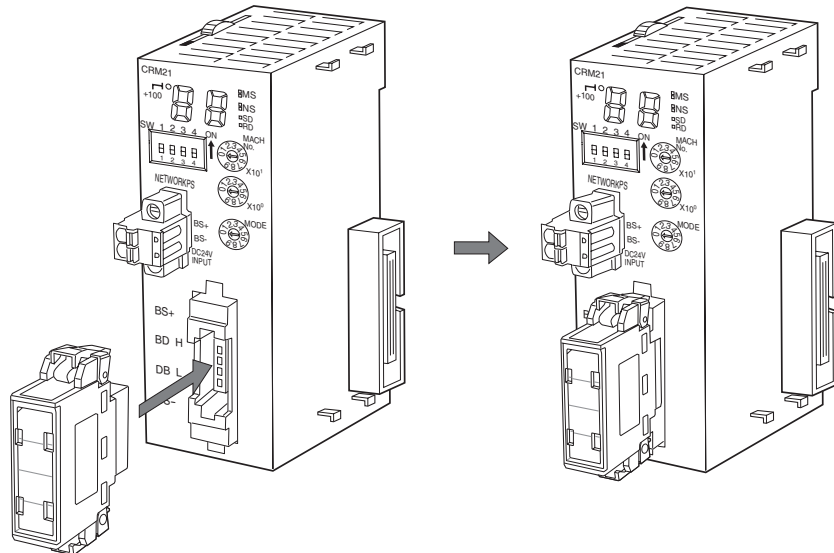

Note To remove the Adapter once it has been attached, press in on the catches on both sides and pull out the Adapter.

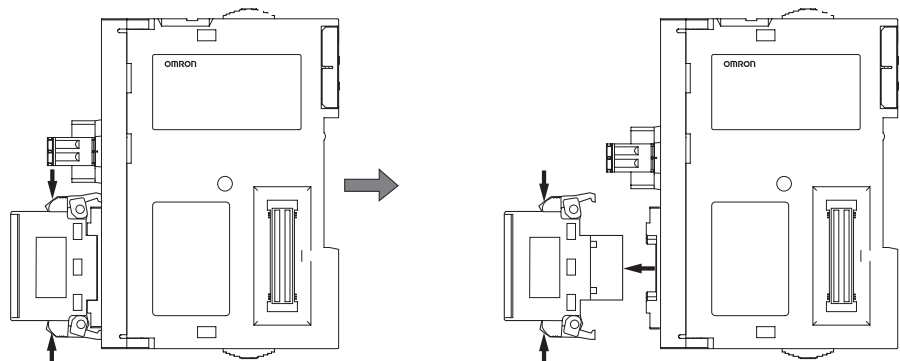

Connecting Trunk Lines, Sub-trunk Lines, Branch Lines, and Sub-branch Lines to Slave Units or Repeater Units

Standard Flat Cable

A DCN4-BR4 Standard Flat Cable Branch Line Pressure-welded Connector is connected to the communications connector on the Slave Unit or Repeater Unit.

Refer to 4-3 *Preparing Pressure-welded Connectors* for information on attaching a cable to the Connector.

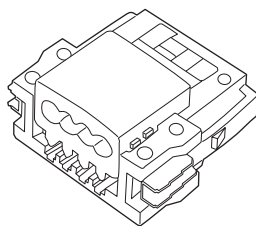

Be sure the face of the Connector on which line colors are indicated (red, white, blue, and black) is facing to the left and press in the Connector until it clicks into place.

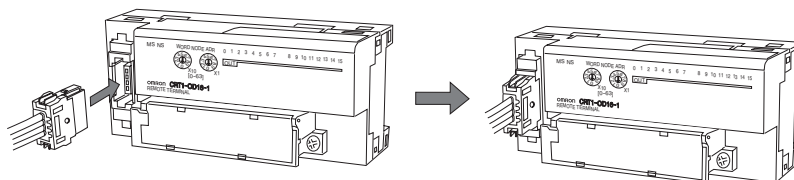

Note To remove a Connector once it has been attached, press in on the catches on both sides and pull out the Connector. Refer to page 76.

Sheathed Flat Cable

A DCN4-BR5 Sheathed Flat Cable Branch Line Pressure-welded Connector is connected to the communications connector on the Slave Unit or Repeater Unit.

Refer to 4-3 *Preparing Pressure-welded Connectors* for information on attaching a cable to the Connector.

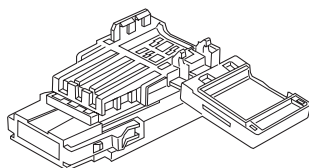

Orient the Connector so that the white line on the cable is facing to the left and press in the Connector until it clicks into place.

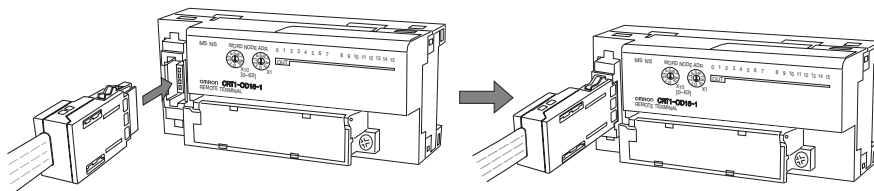

Note To remove a Connector once it has been attached, press in firmly on the catches on both sides of the front of the Connector and pull out the Connector. Refer to page 77.

VCTF 2-conductor Cable

A DCN4-TB4 Terminal Block Adapter is used.

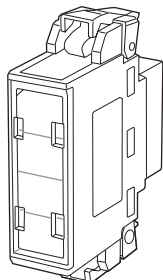

Orient the Adapter so that surface with the open terminals is facing to the left and press in the Adapter until it clicks into place.

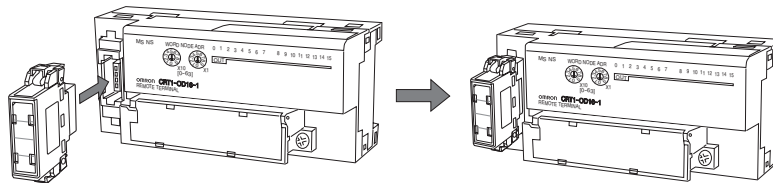

Note To remove the Adapter once it has been attached, press in on the catches on both sides and pull out the Adapter. Refer to page 78.

4-2-3 Branching Lines

T-branches

Creating Branch Lines off Trunk or Sub-trunk Lines and Sub-branch Lines off Branch Lines

■ Standard Flat Cable

A DCN4-BR4 Standard Flat Cable Branch Line Pressure-welded Connector is connected to a DCN4-TR4 Standard Flat Cable Trunk Line Pressure-welded Connector.

Be sure the face of the Standard Flat Cable Branch Line Pressure-welded Connector on which line colors are indicated (red, white, blue, and black) is facing downward and press in the Connector until it clicks into place.

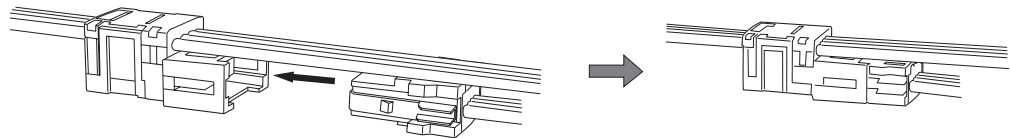

Note To remove the Standard Flat Cable Branch Line Pressure-welded Connector once it has been attached, press in on the catches on both sides and pull out the Connector.

■ Sheathed Flat Cable

A DCN5-BR4 Sheathed Flat Cable Branch Line Pressure-welded Connector is connected to a DCN5-TR4 Sheathed Flat Cable Trunk Line Pressure-welded Connector.

Orient the Sheathed Flat Cable Branch Line Pressure-welded Connector so that the white line on the cable is facing downward and press in the Connector until it clicks into place.

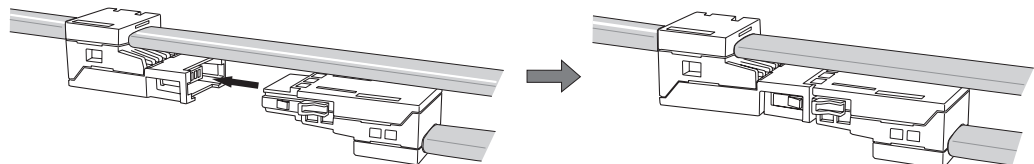

Note To remove the Sheathed Flat Cable Branch Line Pressure-welded Connector once it has been attached, press in firmly on the catches on both sides of the front of the connector and pull out the connector.

■ VCTF 2-conductor Cable

A commercially available relay terminal block is used.

Multidrop Branches

Creating Multi-drop Branches off Trunk Lines, Sub-trunk Lines, Branch Lines, and Sub-branch Lines

■ **VCTF 2-conductor Cable**

A DCN4-TB4 Terminal Block Adapter is used.

Orient the connector so that surface with the open terminals is facing to the left and press in the connector until it clicks into place.

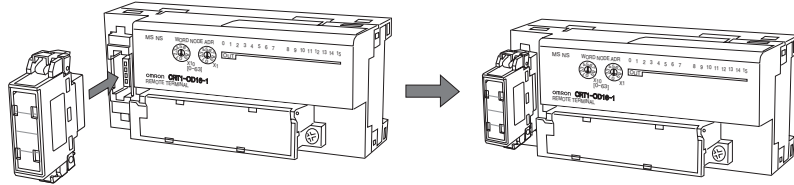

■ **Flat Cable**

A DCN4-MD4 Multi-wiring Connector is used.

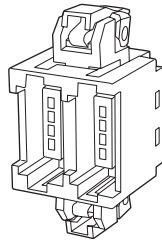

Orient the Connector so that surface with the printed numbers is facing to the left and press in the Connector until it clicks into place.

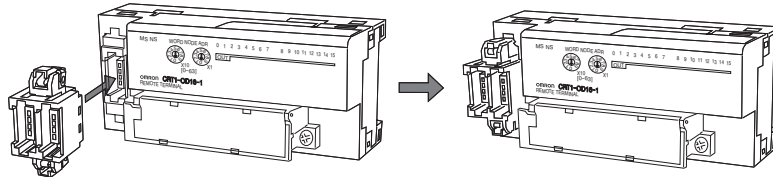

A DCN4-BR4 Standard Flat Cable Branch Line Pressure-welded Connector is connected to the DCN4-MD4 Multi-wiring Connector.

Be sure the face of the Connector on which line colors are indicated (red, white, blue, and black) is facing to the left and press in the Connector until it clicks into place.

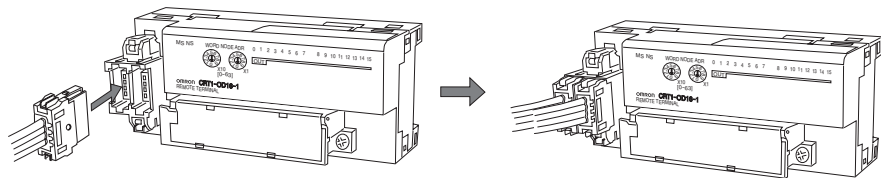

4-2-4 Extending Lines

Extending Trunk Lines, Sub-trunk Lines, and Branch Lines

■ **Standard Flat Cable**

A DCN4-BR4 Standard Flat Cable Branch Line Pressure-welded Connector is connected to a DCN4-TR4 Standard Flat Cable Trunk Line Pressure-welded Connector.

Be sure the face of the Standard Flat Cable Branch Line Pressure-welded Connector on which line colors are indicated (red, white, blue, and black) is facing downward and press in the Connector until it clicks into place.

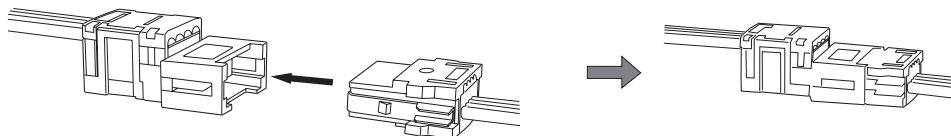

■ **Sheathed Flat Cable**

A DCN5-BR4 Sheathed Flat Cable Branch Line Pressure-welded Connector is connected to a DCN5-TR4 Sheathed Flat Cable Trunk Line Pressure-welded Connector.

Orient the Sheathed Flat Cable Branch Line Pressure-welded Connector so that the white line on the cable is facing downward and press in the Connector until it clicks into place.

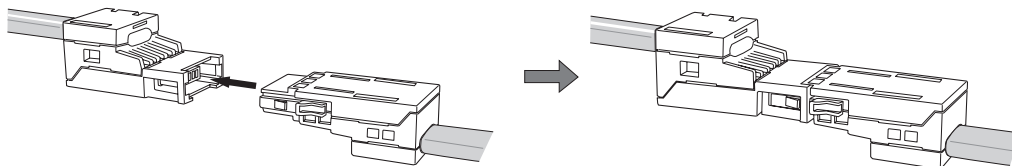

4-2-5 Connecting Terminating Resistance

Trunk Lines and Sub-trunk Lines

■ **Standard Flat Cable**

A DCN4-TM4 Flat Cable Connector-type Terminating Resistor is connected to a DCN4-TR4 Standard Flat Cable Trunk Line Pressure-welded Connector.

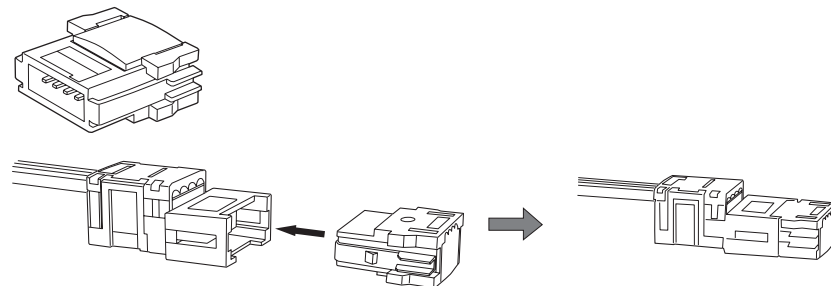

■ Sheathed Flat Cable

A DCN5-TM4 Sheathed Flat Cable Connector-type Terminating Resistor is connected to a DCN5-TR4 Sheathed Flat Cable Trunk Line Pressure-welded Connector.

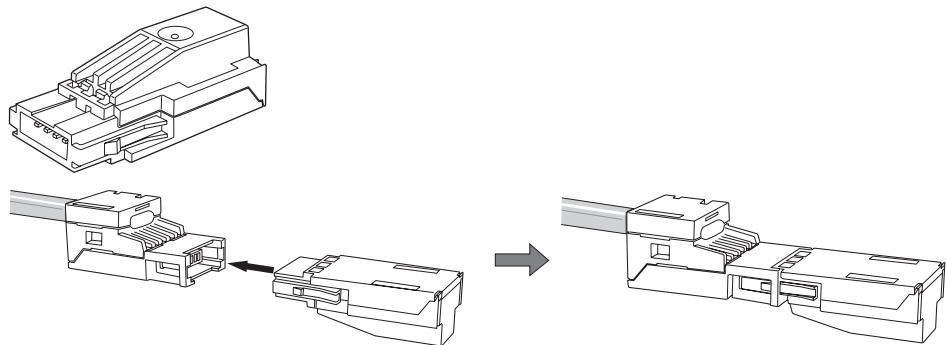

■ VCTF 2-conductor Cable

A DRS1-T Terminal Block-type Terminating Resistor is connected.

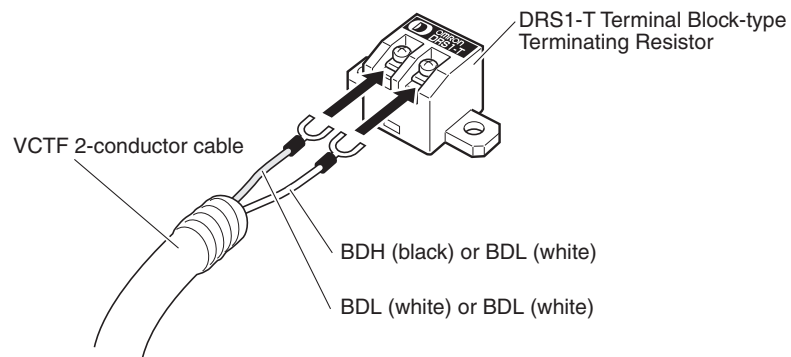

Use the following M3 crimp terminals for the connections. Tighten the terminal screws to 0.3 to 0.5 N·m.



4-3 Preparing Pressure-welded Connectors

This section describes how to prepare CompoNet Network communications cables and pressure-welded connectors.

4-3-1 Tools Required for Installation and Wiring

The following tools are required to prepare pressure-welded connectors.

- Wire cutters: To cut the cable
- Pliers: To crimp pressure-welded connectors
Use one of the following pliers.

For Standard Flat Cable: DWT-A01

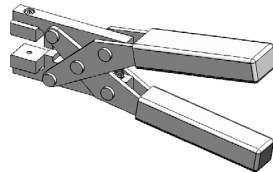

For Sheathed Flat Cable: DWT-A02

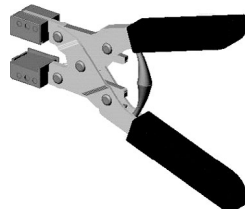

4-3-2 Standard Flat Cables

Use the following procedure to connect a pressure-welded connector to the communications cable.

Note Pressure-welded connectors cannot be reused once they have been connected. Perform the procedure with care. Always hold on to the connector when connecting or disconnecting a connector. When connecting a connector, press it all the way in and then pull out on the connector to be sure it is locked into place. Before connecting a connector, check the cable labels and the cable colors to be sure they match.

DCN4-TR4 Standard Flat Cable Trunk Line Pressure-welded Connectors

DCN4-TR4 Standard Flat Cable Trunk Line Pressure-welded Connector

Cover

Housing

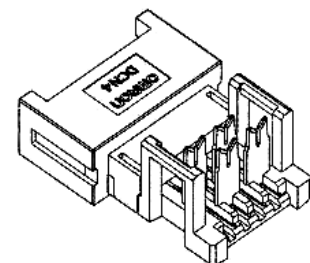
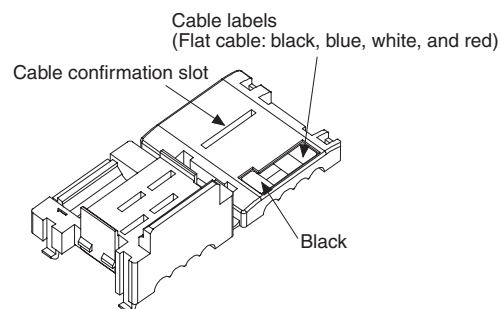

■ **Cutting the Cable**

Cut the cable perpendicular to the length.

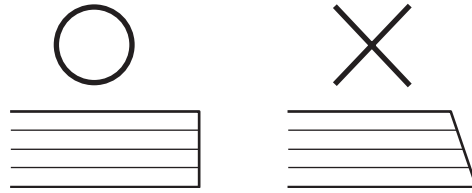

To prevent short-circuits, cut the cable with a sharp blade and be sure that there are no whiskers from the conductors.

■ **Assembling the Cable Stopper (for an Extension or End of Line)**

A stopper must be prepared in advance when extending a line or at the end of the line.

Close the cover, secure the hooks, and then press down on the cable stopper until it clicks into place.

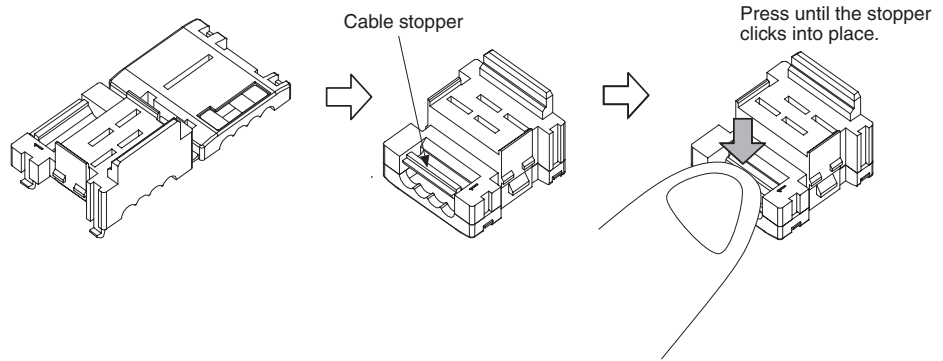

■ **Attaching the Cable**

■ **T-branch Connections**

- 1,2,3... 1. Align the cable labels and cable colors and place the cable into the connector.

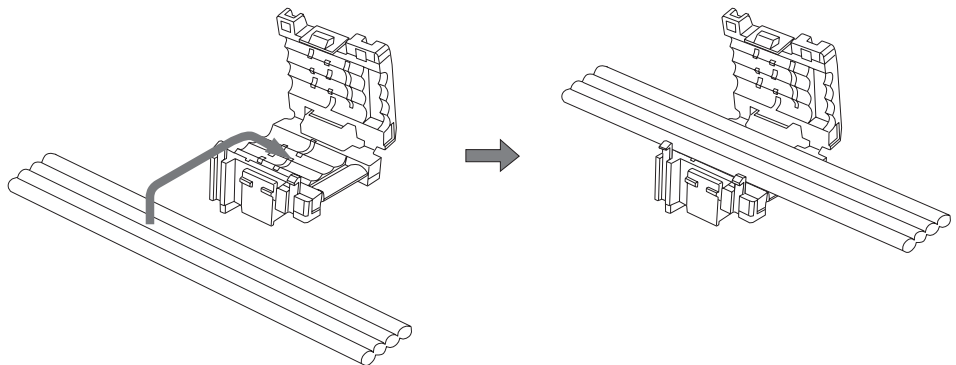

2. Close the cover and secure it with the hooks.

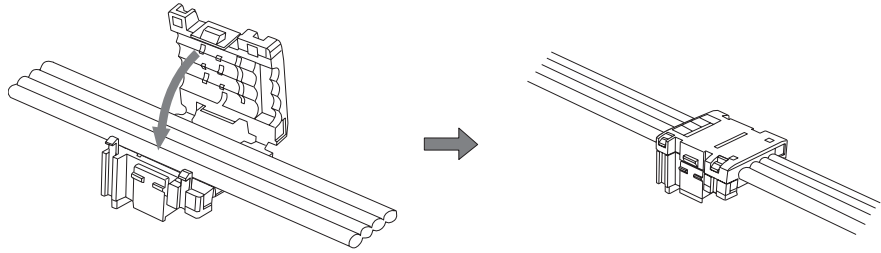

■ **Line Extensions and Line Ends**

Insert the cable all the way into a cover with the cable stopper already prepared.

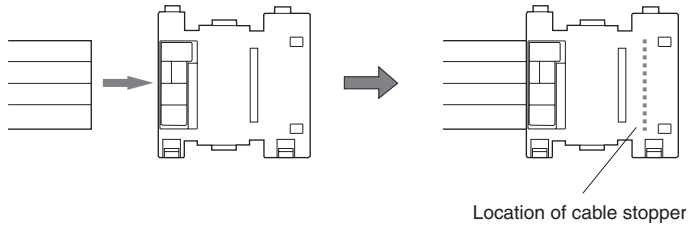

Connector with Cable Attached

T-branch connections:

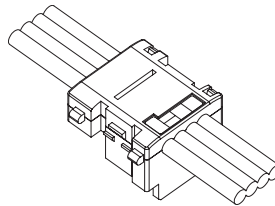

Line extensions and line ends:

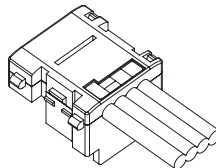

■ **Attaching the Connector Housing**

Confirm that the cable labels and cable colors match and then temporarily secure the housing to the cover.

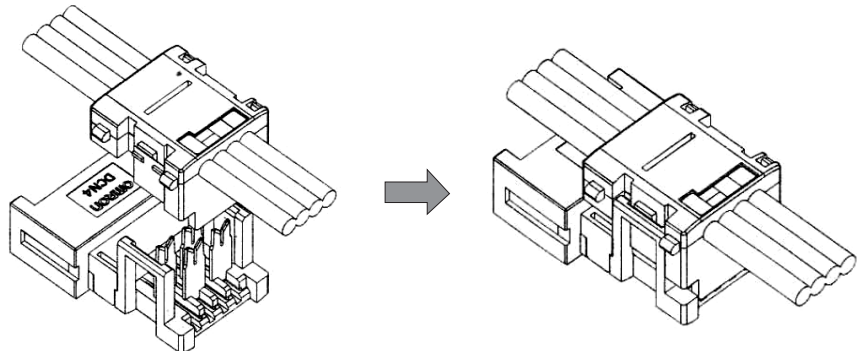

Note The housing cannot be removed from the cover once it has been attached. The connector may be damaged if the housing is forcefully removed.

■ **Pressure-welding the Connector**

The connector is pressure-welded using the DWT-AT01 Pliers.

- 1,2,3... 1. Align the center (see arrow) of the connector cover with the center of the pressure-welding block on the DWT-AT01 Pliers and set the cover in the Pliers.

DCN4-TR4 Standard Flat Cable Trunk Line Pressure-welded Connector

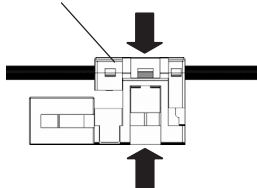

DWT-AT01 Pliers

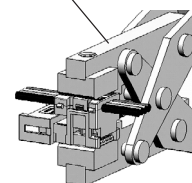

2. Squeeze firmly on the DWT-A01 Pliers until the lock on the connector clicks into place.

- Note** (a) Do not pressure-weld the connector cover at the edges.
 (b) Do not pressure-weld the connector cover at the back of the pressure-welding block.
 (c) Set the connector in the correct orientation.

DCN4-TR4 Standard Flat Cable Trunk Line Pressure-welded Connector

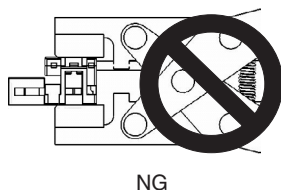
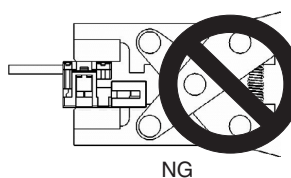
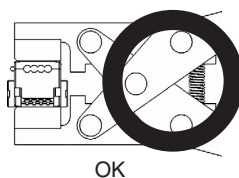

3. After attaching the cable, confirm that it is properly pressure-welded.

DCN4-TR4 Standard Flat Cable Trunk Line Pressure-welded Connector

Be sure the connector is locked on both the left and right sides.

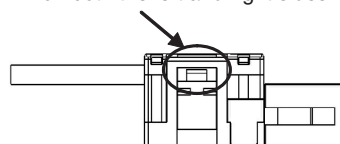
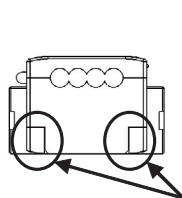

Be sure there are no gaps here.

DCN4-TR4 Standard Flat Cable Branch Line Pressure-welded Connector

DCN4-BR4 Standard Flat Cable Branch Line Pressure-welded Connector

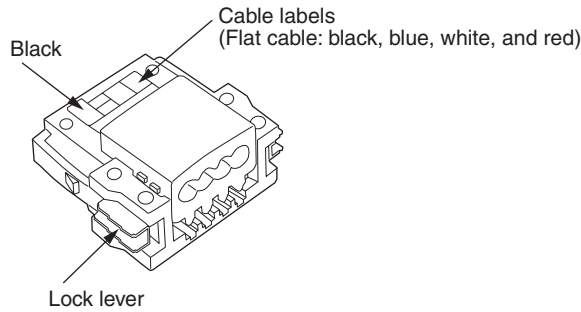

■ **Cutting the Cable**

Cut the cable perpendicular to the length.

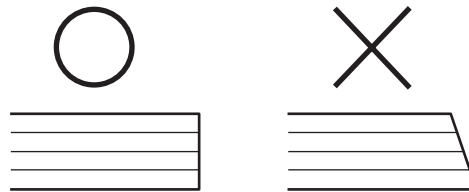

To prevent short-circuits, cut the cable with a sharp blade and be sure that there are no whiskers from the conductors.

■ **Attaching the Cable**

- 1,2,3...
1. Align the cable labels and cable colors and insert the cable into the connector.
 2. Confirm that the cable is inserted all the way to the back. (The cover is semi-transparent.)

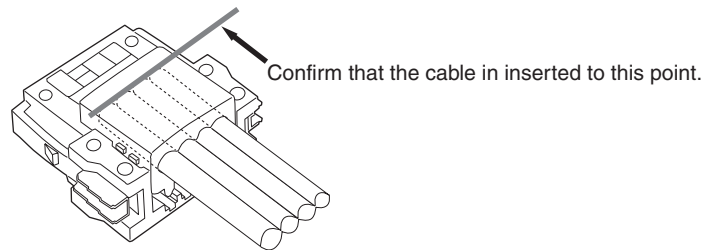

■ **Pressure-welding the Connector**

Before pressure-welding the connector, be sure that the cable is inserted all the way to the back and do not let it be pulled out.

The connector is pressure-welded using the DWT-AT01 Pliers.

- 1,2,3... 1. Align the center (see arrow) or the connector cover with the center of the pressure-welding block on the DWT-AT01 Pliers and set the cover in the Pliers.

DCN4-BR4 Standard Flat Cable Branch Line Pressure-welded Connector

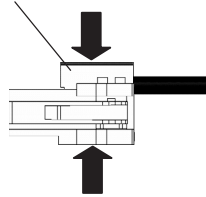

DWT-AT01 Pliers

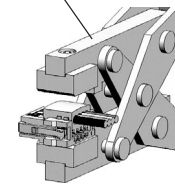

2. Squeeze firmly on the DWT-A01 Pliers until the lock on the connector clicks into place.

- Note** (a) Do not pressure-weld the connector cover at the edges.
 (b) Do not pressure-weld the connector cover at the back of the pressure-welding block.
 (c) Set the connector in the correct orientation.

DCN4-BR4 Standard Flat Cable Branch Line Pressure-welded Connector

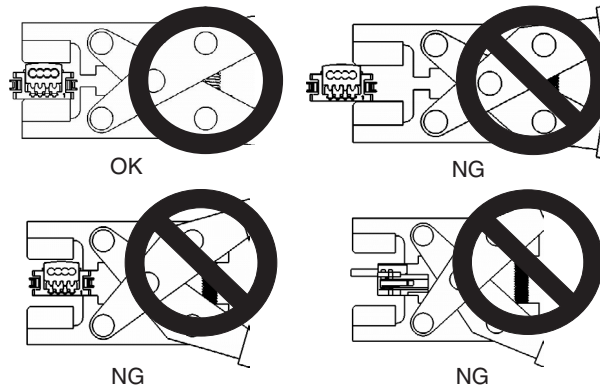

3. After attaching the cable, confirm that it is properly pressure-welded.

DCN4-BR4 Standard Flat Cable Branch Line Pressure-welded Connector

Be sure there are no gaps here.

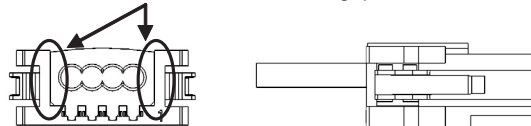

4-3-3 Sheathed Flat Cable

Use the following procedure to connect a pressure-welded connector to a Sheathed Flat Cable.

DCN5-TR4 Sheathed Flat Cable Trunk Line Pressure-welded Connector

DCN5-TR4 Sheathed Flat Cable Trunk Line Pressure-welded Connector

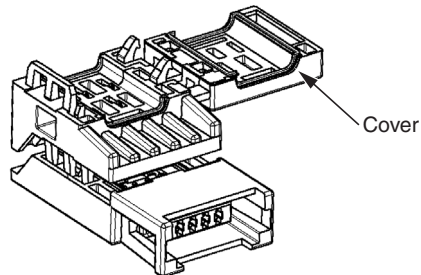

■ **Cutting the Cable**

Cut the cable for an extension or line end perpendicular to the length.



To prevent short-circuits, cut the cable with a sharp blade and be sure that there are no whiskers from the conductors.

■ **Setting the Cable Stopper (for Extension or End of Line)**

A stopper must be set in advance when extending a line or at the end of the line.

Insert the cable into the cover and position it so that the cable end strikes the cable stopper.

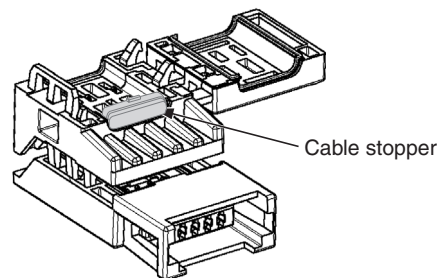

■ **Attaching the Cable**

Place the cable on the connector with the white line on the cable facing upward.

Place the white line on the cable upward and on the opposite of the connector from the cover, as shown in the figure.

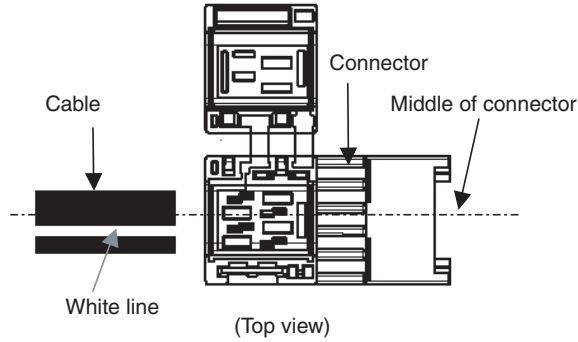

■ **T-branch Connections**

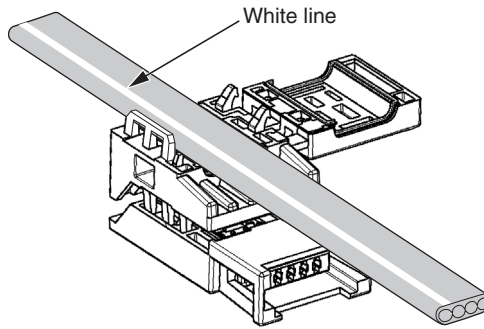

■ **Line Extensions and Line Ends**

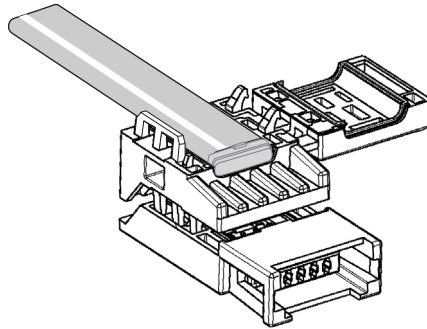

■ **Pressure-welding the Connector**

1,2,3...

1. Hold the cable so that it does not move and close the cover.

Note For extensions and line ends, be sure that the cable is inserted all the way to the cable stopper and do not let it be pulled out.

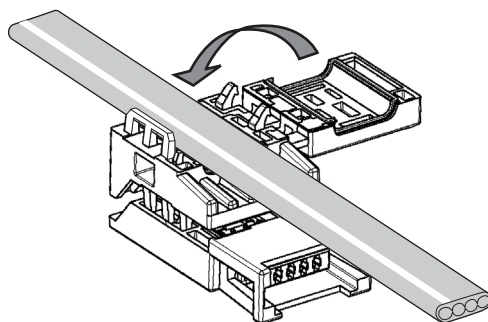

2. The connector is pressure-welded using the DWT-AT02 Pliers.

Note When placing the connector on the pressure-welding block, align it using the reference surfaces shown in the following figure.

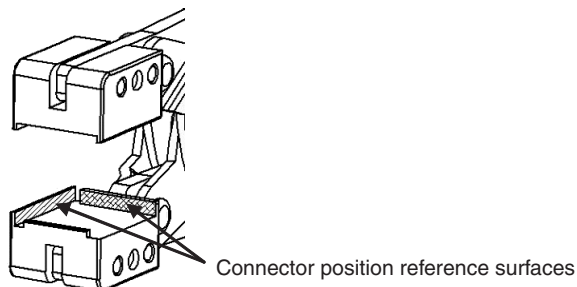

3. Set the connector on the pressure-welding block of the DWT-A02 Pliers as shown in the following figure and pressure-weld it in the direction indicated by the arrow.

DCN5-TR4 Sheathed Flat Cable Trunk Line Pressure-welded Connector

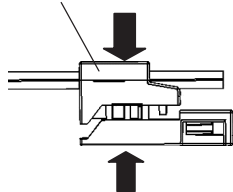

DWT-AT02 Pliers

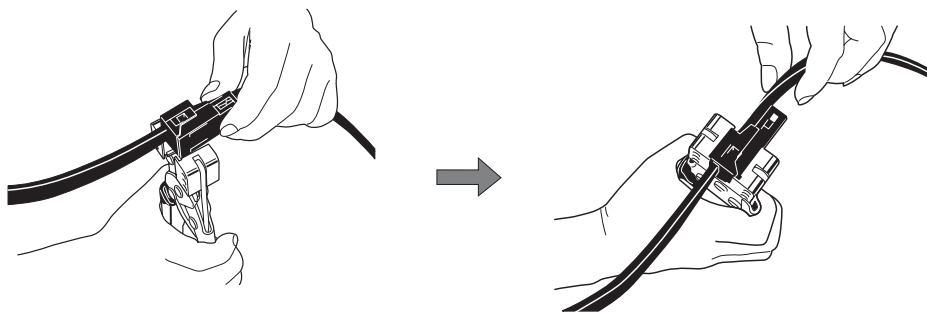
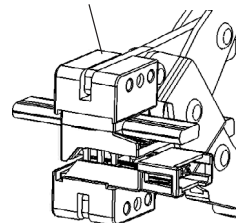

- 4. Squeeze firmly on the DWT-A02 Pliers until the lock on the connector clicks into place.

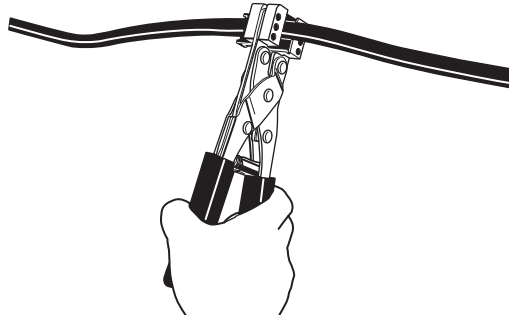

- 5. After attaching the cable, confirm that it is properly pressure-welded.

DCN5-TR4 Sheathed Flat Cable Trunk Line Pressure-welded Connector

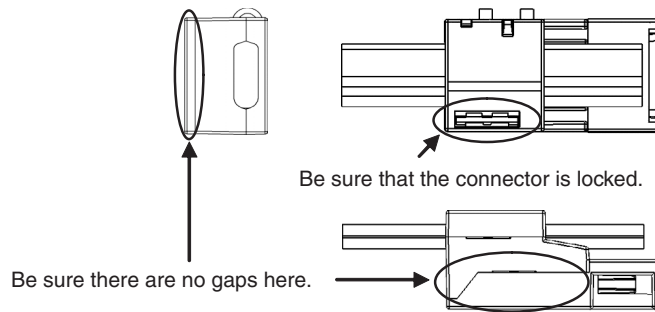

DCN5-BR4 Sheathed Flat Cable Branch Line Pressure-welded Connector

DCN5-BR4 Sheathed Flat Cable Branch Line Pressure-welded Connector

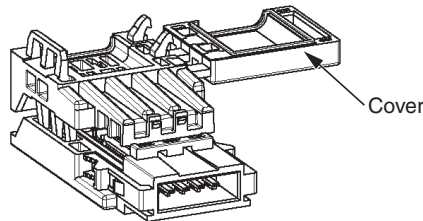

■ Cutting the Cable

Cut the cable perpendicular to the length.



To prevent short-circuits, cut the cable with a sharp blade and be sure that there are no whiskers from the conductors.

■ **Attaching the Cable**

Set the end of the cable as shown in the following figure.
 Be sure that the red line at the cable end is opposite of the cover.

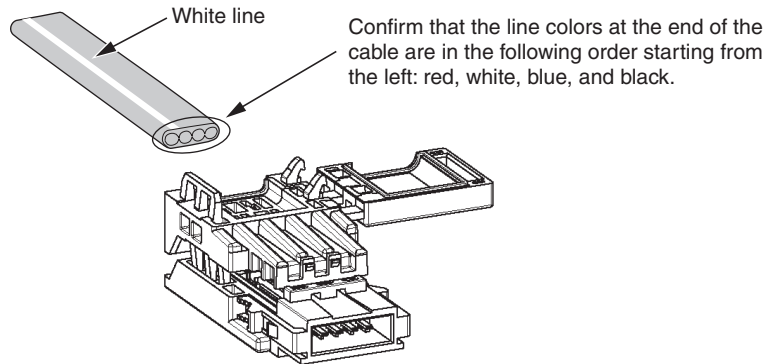

■ **Pressure-welding the Connector**

- 1,2,3... 1. Hold the cable so that it does not move and close the cover.

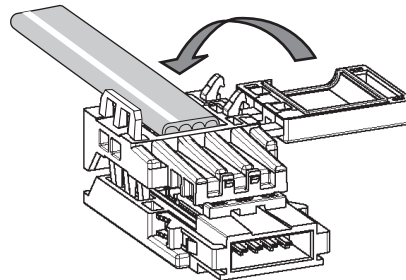

2. The connector is pressure-welded using the DWT-AT02 Pliers.

Note When placing the connector on the pressure-welding block, align it using the reference surfaces shown in the following figure.

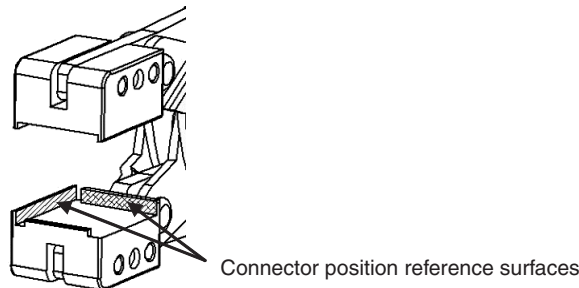

3. Set the connector on the pressure-welding block of the DWT-A02 Pliers as shown in the following figure and pressure-weld it in the direction indicated by the arrow.

DCN5-BR4 Sheathed Flat Cable Branch Line Pressure-welded Connector

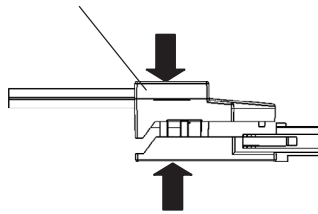

DWT-AT02 Pliers

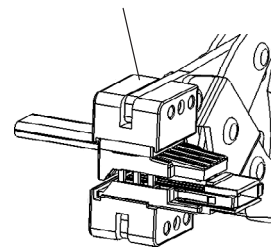

4. Squeeze firmly on the DWT-A02 Pliers until the lock on the connector clicks into place.
5. After attaching the cable, confirm that it is properly pressure-welded.

DCN5-BR4 Sheathed Flat Cable Branch Line Pressure-welded Connector

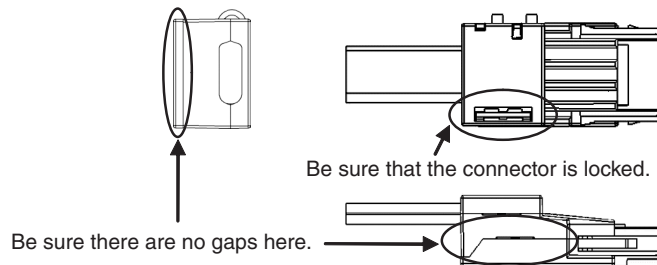

4-4 Power Supply Wiring

The following power supplies are required to operate the CompoNet Network.

- Communications power supply: Used for node communications and internal circuit operation.
- I/O power supply: Used for external I/O operation for Slave Units with contact I/O.

Note The Master Unit operation using the power supply from the PLC's Power Supply Unit. No external power supply is required for the Master Unit.

4-4-1 Supplying Power to Slave Units

Slave Units are supplied power as listed in the following table.

Slave Unit classification according to power supply method	Power supply		Cable type		Applicable Slave Units
	Communications power supply	I/O power supply	Flat Cable	VCTF 2-conductor cable	
Multi-power supply	Power can be supplied either through the Flat Cable or to each Slave Unit externally.	Power cannot be supplied through the Flat Cable and must be supplied to each Slave Unit externally.	Communications power is supplied to all Slave Units through the communications cable.	Communications power is supply to each Slave Unit externally.	Word Slave Units
Network power supply	The communications power and I/O power are supplied together through the Flat Cable.			NA (See note.)	Bit Slave Units

Note Bit Slave Units are sold with a Flat Cable already attached to them. VCTF 2-conductor cable cannot be used.

Multi-power Supply Slave Units

The communications power can be supplied either through the network (Flat Cable) or from an external source.

- If the Flat Cable is used, the communications power supply is connected to the communications power supply connector on the Master Unit or to the downstream port communications power supply connector on the Repeater Unit.
- If VCTF 2-conductor cable is used, the communications power supply must be supplied to the communications power supply terminals on each Slave Unit. To prevent noise, use separate power supplies for I/O and communications.

Flat Cable

Communications power is supplied to all Slave Units through the Flat Cable.

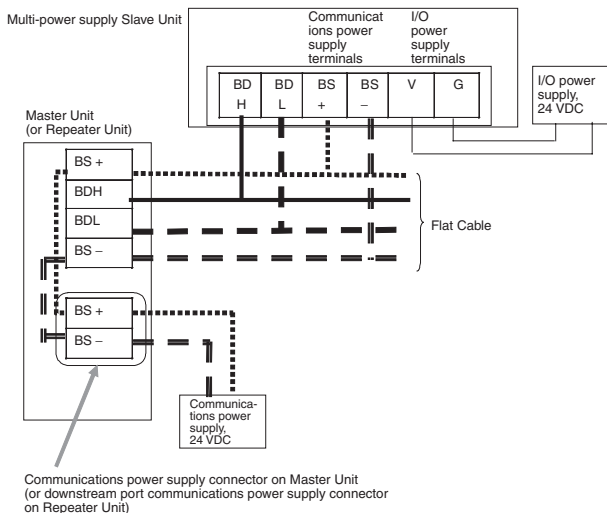

VCTF 2-conductor cable

Communications power is supply to each Slave Unit externally.

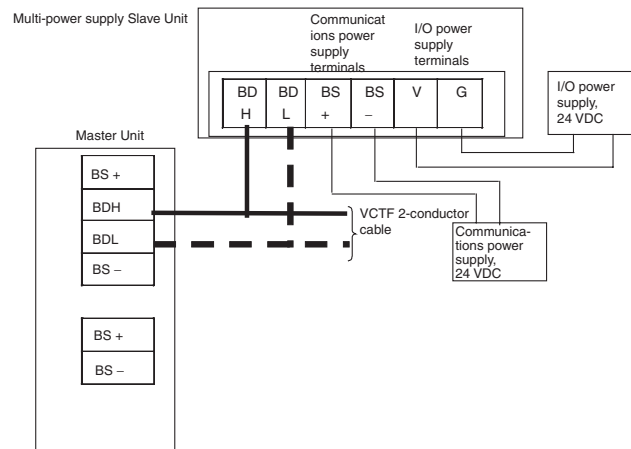

Network Power Supply Slave Units

These Slave Units have only one set of power supply terminals for both communications and I/O power. They use relatively little current and are all supplied power from the network.

For example, Bit Slave Units are sold with a Flat Cable already attached and power can be supplied only through the Flat Cable (communications cable).

Power is supplied from the Master Unit or Repeater Unit.

Communications power is supplied to all Slave Units through the Flat Cable.

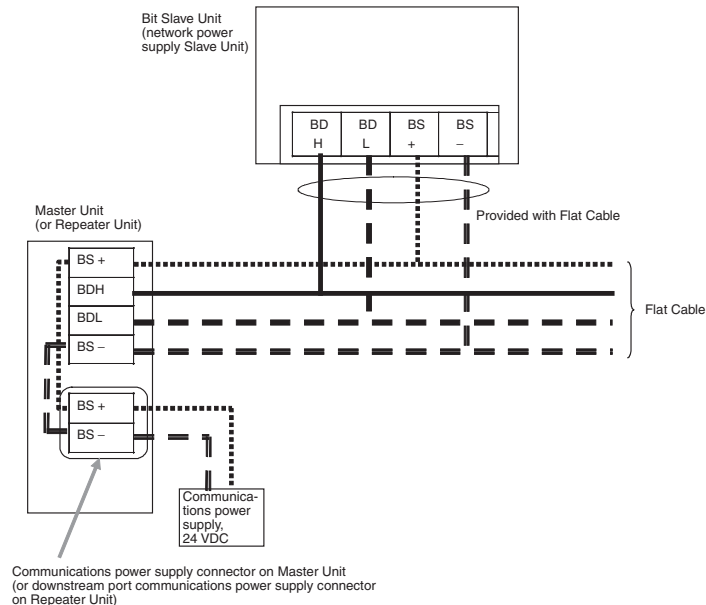

4-4-2 Connecting the Communications Power Supply

Using Flat Cable

Master Unit Connections

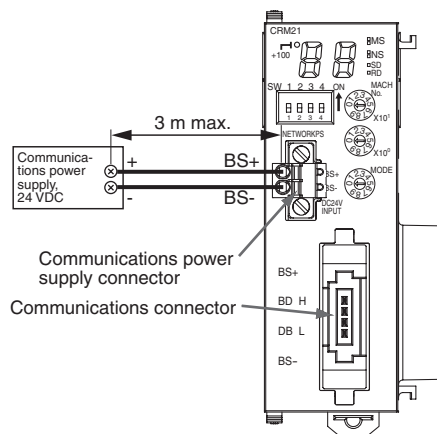

Repeater Unit Connections

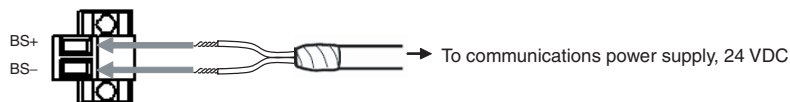
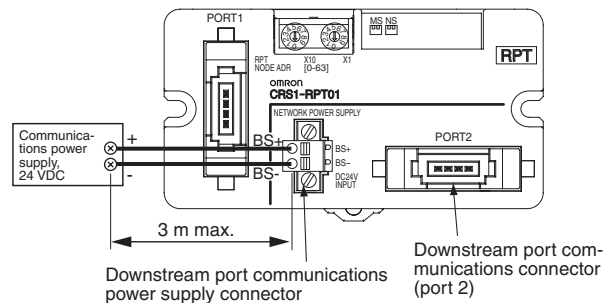

Using VCTF 2-conductor Cable

Slave Unit Connections

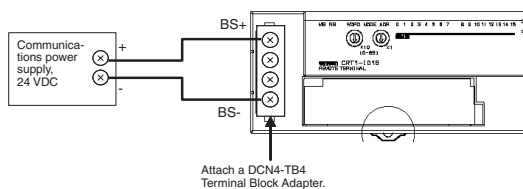

Repeater Unit Connections

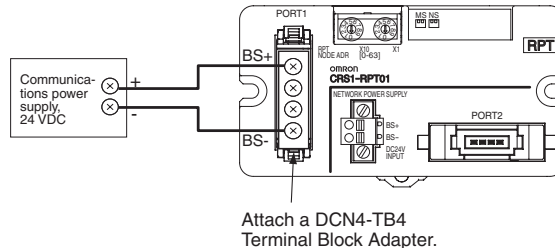

4-4-3 Communications Power Supply Specifications

Use a commercially available power supply that meets the following specifications for the CompoNet Network communications power supply.

- 24 VDC
- A power supply capacity (i.e., output current) that exceeds the following total current consumption
 - The current consumption of all Word Slave Units and Repeater Units
 - The current consumption of all Bit Slave Units and the external I/O current consumption for all Bit Slave Units
- A isolated power supply (The AC input and DC output must be isolated.)

Note For network power supply Slave Units, the external I/O current is also provided through the Flat Cable from the communications power supply connected to the Master Unit or the Repeater Unit. When calculating the output current of the communications power supply, always include the external I/O current consumption and actual load current for network power supply Slave Units. For example, the power supply current consumption for Bit Slave Unit is expressed by the following formula.

- Input Bit Slave Units:
 Communications power supply current consumption = Bit Slave Unit communications current consumption + (Bit Slave Unit input current × number of inputs used) + (sensor current consumption × number of sensors used)
- Output Bit Slave Units:
 Communications power supply current consumption = Bit Slave Unit communications current consumption + (actual load current × number of actuators used)
- I/O Bit Slave Units:
 Communications power supply current consumption = Bit Slave Unit communications current consumption + (Bit Slave Unit input current × number of inputs used) + (sensor current consumption × number of sensors used) + (actual load current number of actuators used)

Power Supply Specifications

Use a communications power supply that meets the following specifications.

Item	Specification
Output voltage	24 VDC ±10%
Output ripple	600 mVp-p
Isolation	Output must be isolated from AC power supply and output must be isolated from case ground.

We recommend an OMRON S82-series Power Supply for the communications power supply for CompoNet Slaves.

4-4-4 Current Consumption

Word Slave Units

Digital I/O Slave Units

Name	I/O capacity	Model	Communications power supply current consumption
Basic Units (transistor-type)	16 DC inputs (NPN)	CRT1-ID16	85 mA max.
	16 DC inputs (PNP)	CRT1-ID16-1	85 mA max.
	16 transistor outputs (NPN)	CRT1-OD16	85 mA max.
	16 transistor outputs (PNP)	CRT1-OD16-1	85 mA max.
Expansion Units (transistor-type)	8 DC inputs (NPN)	XWT-ID08	5 mA max.
	8 DC inputs (PNP)	XWT-ID08-1	5 mA max.
	8 transistor outputs (NPN)	XWT-OD08	5 mA max.
	8 transistor outputs (PNP)	XWT-OD08-1	5 mA max.
	16 DC inputs (NPN)	XWT-ID16	10 mA max.
	16 DC inputs (PNP)	XWT-ID16-1	10 mA max.
	16 transistor outputs (NPN)	XWT-OD16	10 mA max.
	16 transistor outputs (PNP)	XWT-OD16-1	10 mA max.

Analog I/O Slave Units

Name	I/O capacity	Model	Communications power supply current consumption
Analog Terminals	4 inputs (0 to 5 V, 1 to 5 V, 0 to 10 V, -10 to 10 V, 0 to 20 mA, 4 to 20 mA)	CRT1-AD04	175 mA
	2 outputs (0 to 5 V, 1 to 5 V, 0 to 10 V, -10 to 10 V, 0 to 20 mA, 4 to 20 mA)	CRT1-DA02	205 mA

Bit Slave Units

Name	Name	Model	Communications power supply current consumption
Bit Slave Units	IP20-conforming, 2 DC inputs, industrial standard connector (e-CON) (NPN)	CRT1B-ID02S	80 mA max. (See note 1.)
	IP20-conforming, 2 DC inputs, industrial standard connector (e-CON) (PNP)	CRT1B-ID02S-1	75 mA max. (See note 1.)
	IP20-conforming, 2 transistor outputs, industrial standard connector (e-CON) (NPN)	CRT1B-OD02S	75 mA max. (See note 2.)
	IP20-conforming, 2 transistor outputs, industrial standard connector (e-CON) (PNP)	CRT1B-OD02S-1	70 mA max. (See note 2.)
	IP54-conforming, 2 DC inputs, industrial standard connector (e-CON) (NPN)	CRT1B-ID02SP	80 mA max. (See note 1.)
	IP54-conforming, 2 DC inputs, industrial standard connector (e-CON) (PNP)	CRT1B-ID02SP-1	80 mA max. (See note 1.)
	IP54-conforming, 4 DC inputs, industrial standard connector (e-CON) (NPN)	CRT1B-ID04SP	90 mA max. (See note 1.)
	IP54-conforming, 4 DC inputs, industrial standard connector (e-CON) (PNP)	CRT1B-ID04SP-1	90 mA max. (See note 1.)
	IP54-conforming, 2 transistor outputs, industrial standard connector (e-CON) (NPN)	CRT1B-OD02SP	75 mA max. (See note 2.)
	IP54-conforming, 2 transistor outputs, industrial standard connector (e-CON) (PNP)	CRT1B-OD02SP-1	75 mA max. (See note 2.)
	IP54-conforming, 2 transistor outputs/2 transistor outputs, clamp terminal block (NPN)	CRT1B-MD04SLP	90 mA max. (See note 3.)
	IP54-conforming, 2 transistor outputs/2 transistor outputs, clamp terminal block (PNP)	RT1B-MD04SLP-1	85 mA max. (See note 3.)

Note

- (1) The current consumption is for when all inputs are OFF, i.e., it does not include input device current consumption. The communications power supply is also used for the I/O power supply for sensors. Be sure to consider the sensor current consumption and the number of sensors connected.

The power supply current consumption is expressed by the following formula.

Communications power supply current consumption = Bit Slave Unit current consumption + (input current + sensor current consumption) × number of sensors used

- (2) The current consumption is for when all outputs are OFF, i.e., it does not include output device current consumption. The communications power supply is also used for the I/O power supply for actuators. Be sure to consider the actuator current consumption and the number of actuators connected.

The power supply current consumption is expressed by the following for-

mula.

Communications power supply current consumption = Bit Slave Unit current consumption + (output current + actuator current consumption) number of actuators used

- (3) The current consumption is for when all inputs and outputs are OFF, i.e., it does not include input and output device current consumption. The communications power supply is also used for the I/O power supply for sensors and actuators. Be sure to consider the sensor and actuator current consumption and the number of sensors and actuators connected. The power supply current consumption is expressed by the following formula.

Communications power supply current consumption = Bit Slave Unit current consumption + (input current + sensor current consumption) × number of sensors used + (output current + actuator current consumption) × number of actuators used

Repeater Unit

Name	Model	Communications power supply current consumption
Repeater Unit	CRS1-RPT01	95 mA max.

4-4-5 Communications Power Supply Wiring Examples

Using Flat Cable

When Flat Cable is used, the Slave Unit communications power is supplied through the Flat Cable. There is no special wiring required for the communications power supply. The same communications power supply is shared for the entire trunk line or sub-trunk line.

For multi-power supply Slave Units, however, I/O power must be supplied separately.

Restrictions

The following restrictions exist when supplying communications power through a Flat Cable.

- The communications power supply can be connected at only one location for the trunk line and one location each for the sub-trunk lines. Communications power to the trunk line can be supplied only through the communications power supply connector on the Master Unit. Communications power to a sub-trunk line can be supplied only through the downstream port communications power supply connector on the Repeater Unit. Communications power cannot be supplied at any other location.

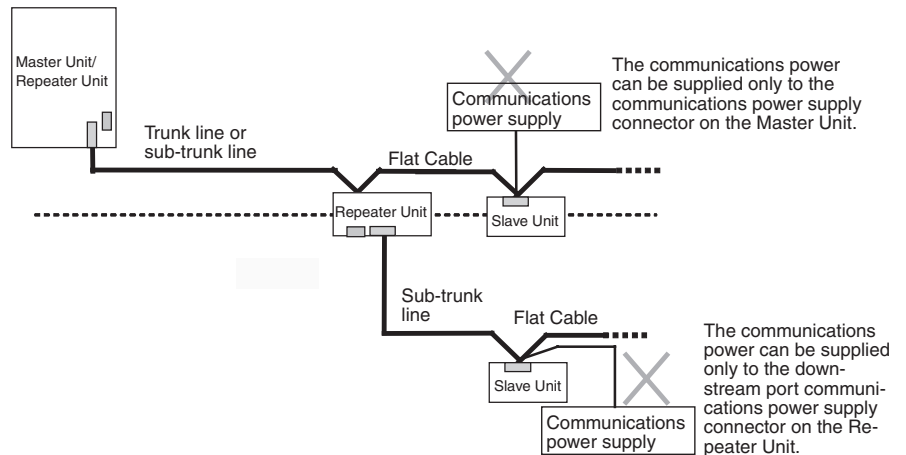
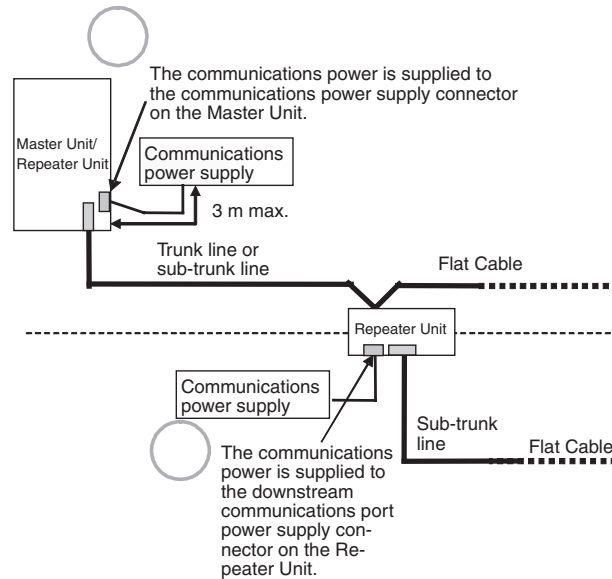

- Use separate power supplies for the trunk line and for each sub-trunk line (i.e., for the trunk line or sub-trunk line upstream from a Repeater Unit and the sub-trunk line downstream from a Repeater Unit).

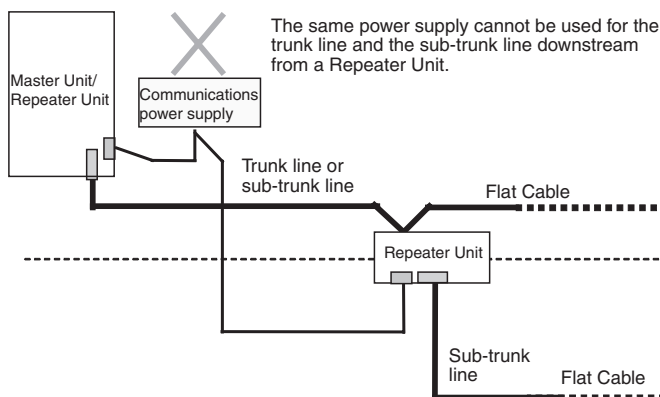
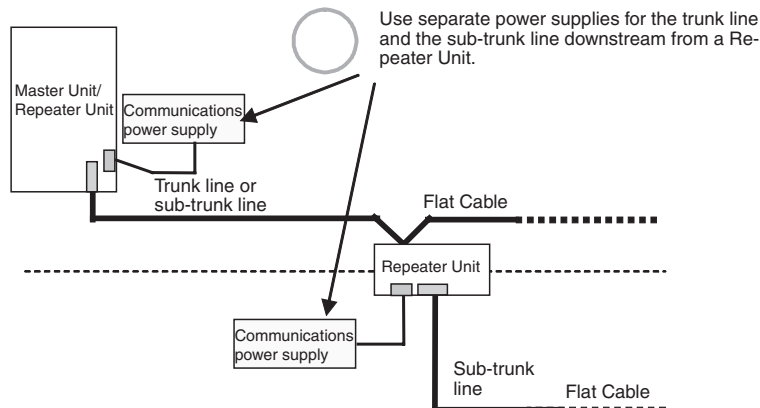

Transmission quality will not be maintained and communications errors may occur if this restriction is not observed.

Power supply wiring examples are provided below.

Not Using a Repeater Unit

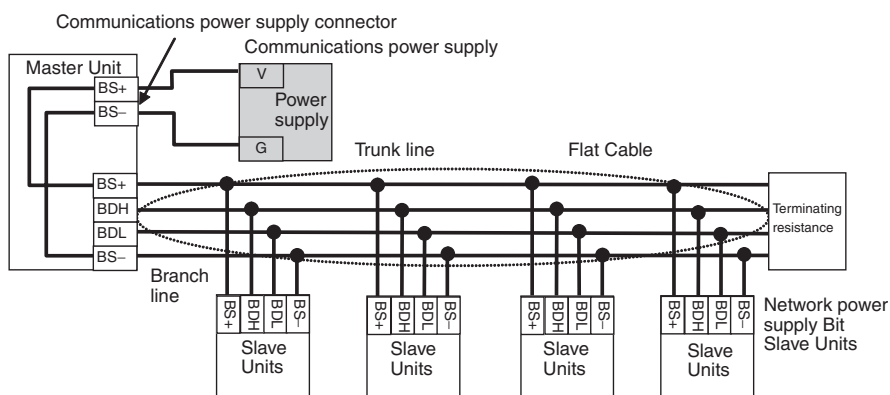

Using a Repeater Unit

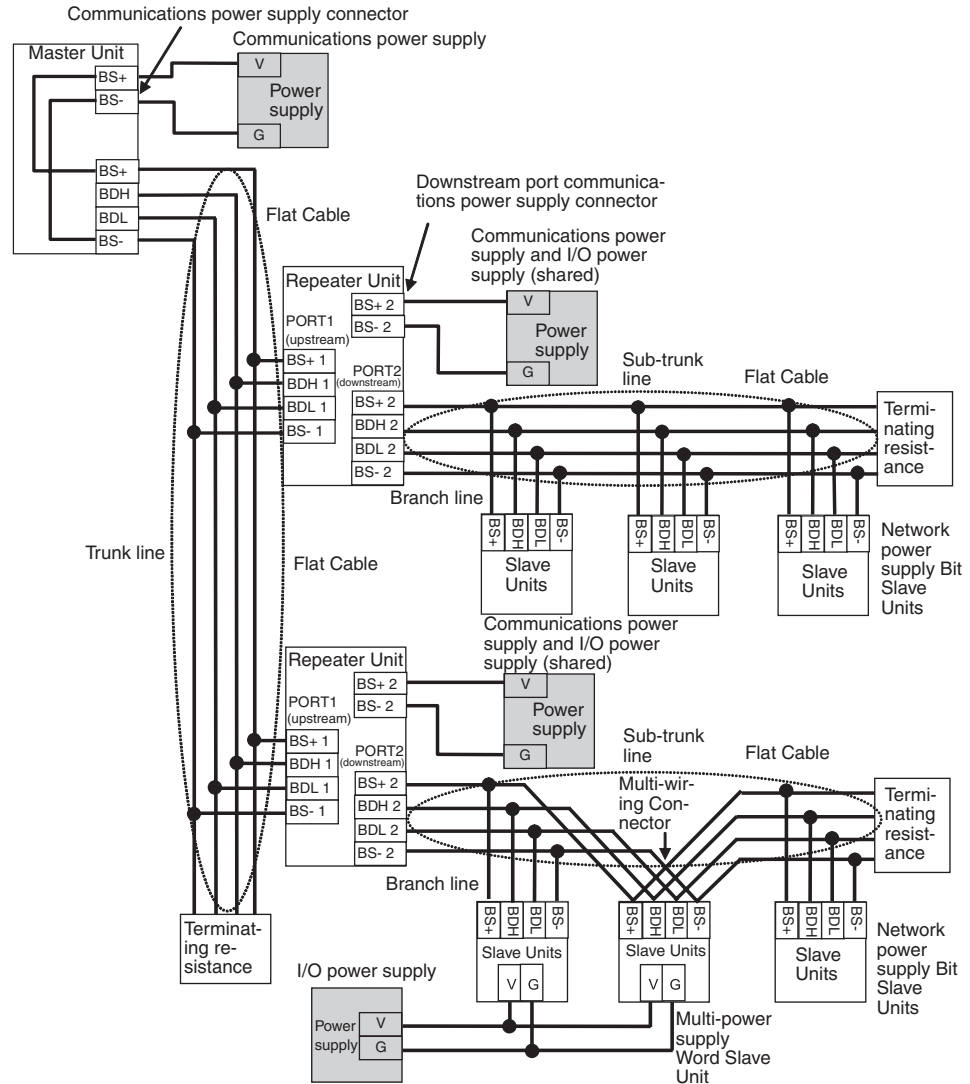

- Note**
- (1) Absolutely do not supply communications power from more than one location for the trunk line or for any one sub-trunk line. The quality of communications will decrease and normal remote I/O communications may not be possible.
 - (2) Do not supply communications power to the trunk line and a sub-trunk line or to two sub-trunk lines from the same power supply. The quality of communications will decrease and normal remote I/O communications may not be possible.
 - (3) The I/O power supply to multi-power supply Slave Units may be a source of noise depending on the connected devices. Even when supplying the communications power supply together to all Slave Units, use a separate I/O power supply so that noise does not affect the network.

VCTF 2-conductor Cable

When using VCTF 2-conductor cable, the communications power cannot be supplied through the communications cable.

The communications power must be supplied to each Slave Unit and Repeater Unit through separate lines.

For multi-power supply Slave Units that require power for I/O, the I/O power must also be supplied separately.

- Note** (a) No external power supply is required for the Master Unit.
 (b) The communications power to the Repeater Unit must be supplied to the BS+A and BS-A terminals on the upstream port (port 1).

Not Using a Repeater Unit

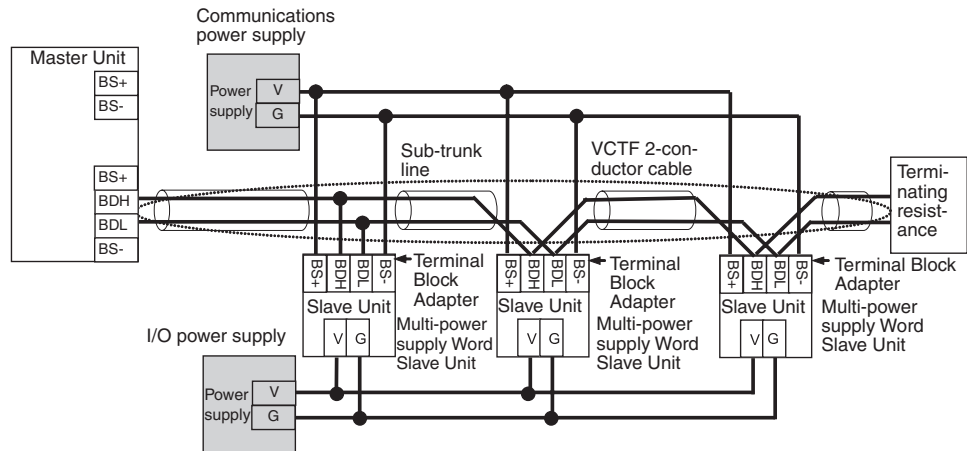

Using a Repeater Unit

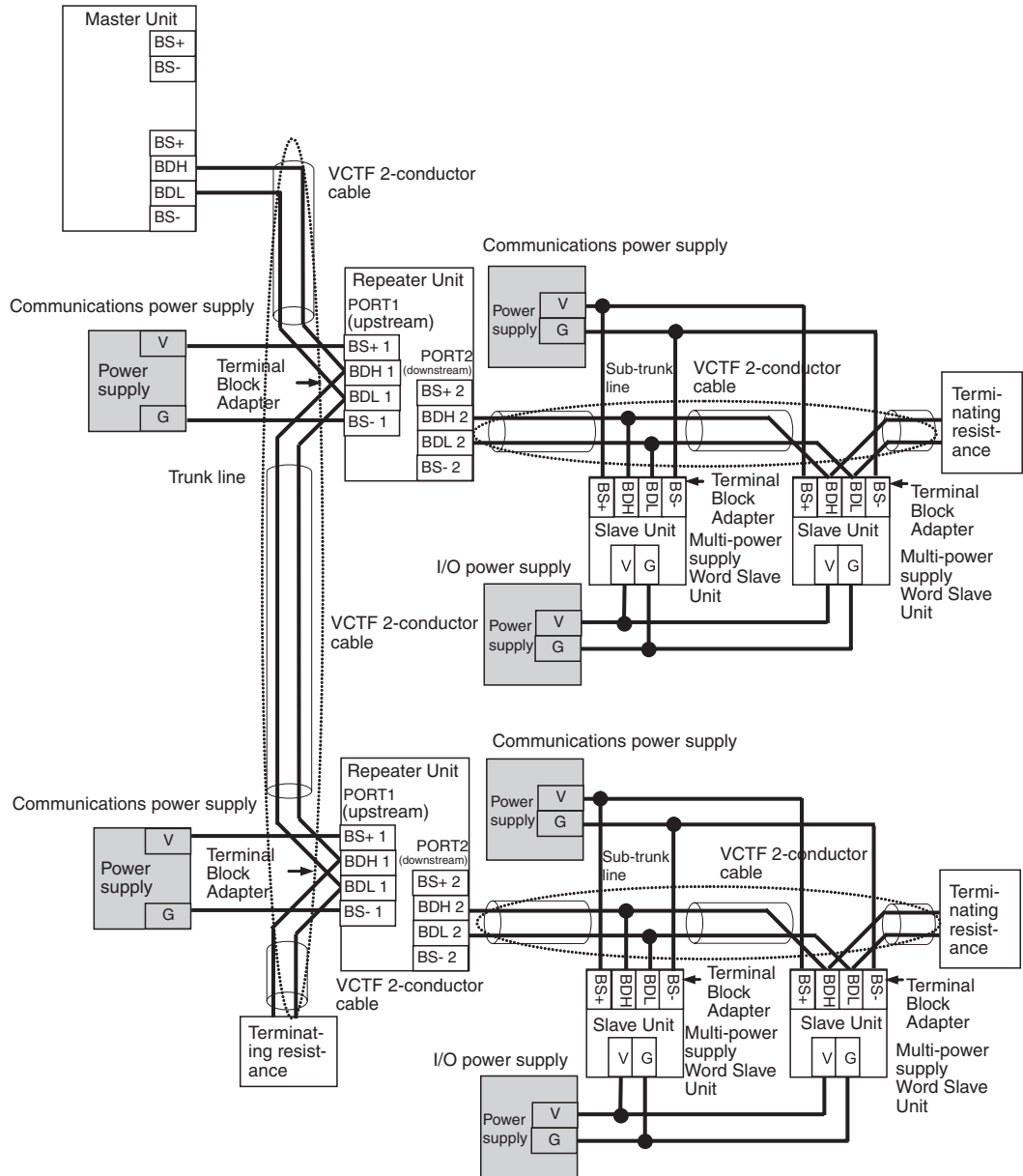

Note The I/O power supply to multi-power supply Slave Units may be a source of noise depending on the connected devices. Even when supplying the communications power supply together to all Slave Units, use a separate I/O power supply so that noise does not affect the network.

Using VCTF 2-conductor Cable and Flat Cable Together

One or more Repeater Units can be use in a CompoNet Network to use both VCTF 2-conductor cable and Standard or Sheathed Flat Cable under the same Master Unit.

Note (a) No external power supply is required for the Master Unit.

(b) As long as Flat Cable is not used both upstream and downstream from a Repeater Unit, then the same communications power supply can be used for both the upstream trunk line or sub-trunk line and the downstream sub-trunk line.

A power supply wiring example is provided below.

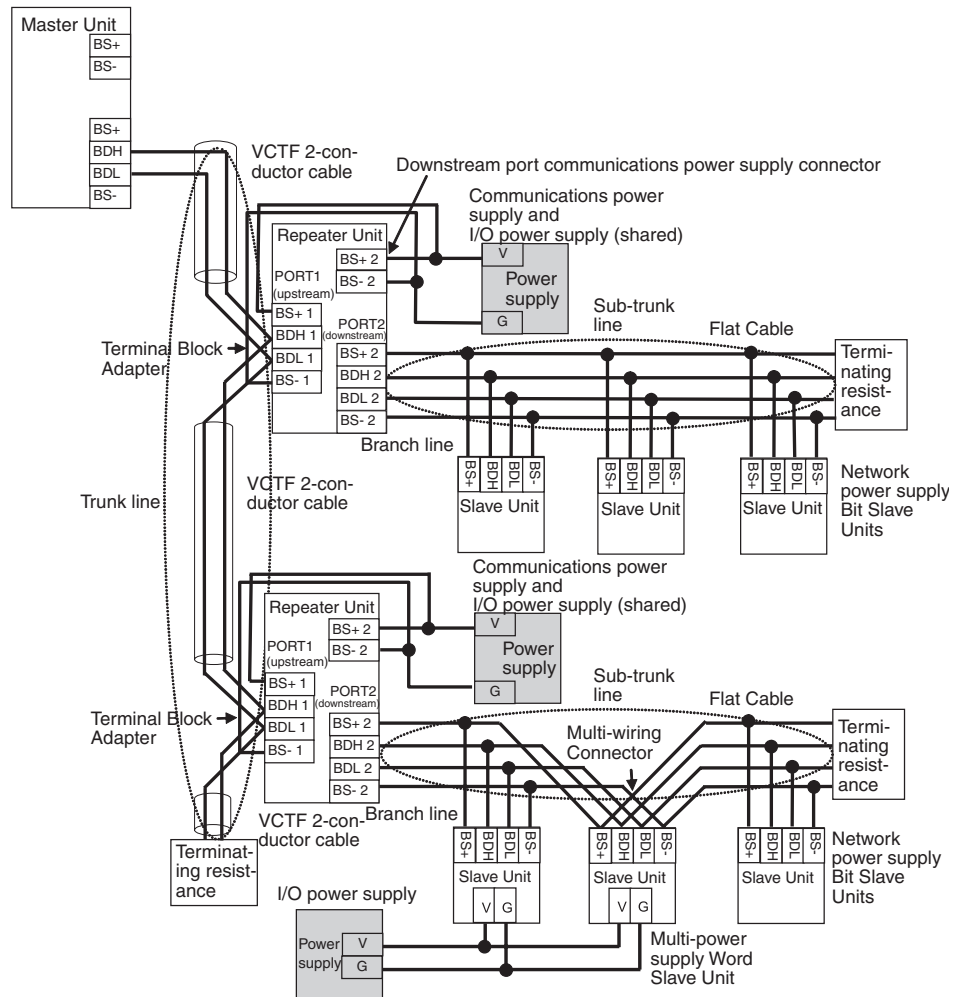

Note The I/O power supply to multi-power supply Slave Units may be a source of noise depending on the connected devices. Even when supplying the communications power supply together to all Slave Units, use a separate I/O power supply so that noise does not affect the network.

4-4-6 Precaution in Supplying Power to Slave Units

When supplying communications power and I/O power, the allowable currents of cables and connections, the voltage drop, and the capacity and location of power supplies must be considered.

Allowable Current Restrictions

Do not allow the total current consumption of all Slave Units to exceed the allowable current of the communications cables and connectors.

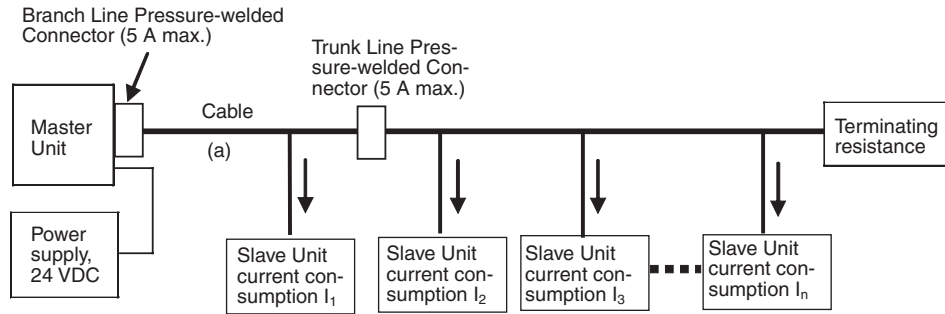

Allowable Currents for Cables

Select the communications cable so that the total current consumption of all Slave Units does not exceed the allowable current of the cable.

$$\text{Cable allowable current} \geq I_1 + I_2 + I_3 + \dots + I_n$$

(For the allowable cable current for "a" in the above diagram)

Allowable Currents for Connectors

There are limits to the allowable current for the communications power supply connectors on the Master Unit and Repeater Units, Trunk Line Pressure-welded Connectors, and Branch Line Pressure-welded Connectors. Do not allow the current flow where these connectors are used to exceed the allowable current.

Name	Model	Allowable current	Remarks
Communications power supply connectors on CS/CJ-Master Units	CS1W-CRM21	5 A	VCTF 2-conductor cable or Flat Cable
	CJ1W-CRM21		
Communications power supply connector on Repeater Unit	CRS1-RPT01		
Trunk Line Pressure-welded Connectors	DCN4-TR4		
	DCN5-TR4		
Branch Line Pressure-welded Connectors	DCN4-BR4		
	DCN5-BR4		
Multi-wiring Connector	DCN4-MD4		

Note If the allowable current is exceeded, heating and burning may result.

Voltage Drop

Cable Voltage Drop

The voltage drop must be considered so that the power supply voltage at the Slave Unit that is the farthest from the power supply will still be within the allowable power supply range.

The voltage drop is expressed by the following formula.

$$\text{Voltage drop (V)} = \text{Current (A)} \times \text{Cable conductor resistance } (\Omega/\text{m}) \times \text{Cable length (m)} \times 2$$

If the voltage drop is too large and power cannot be supplied to the farthest Slave Unit within the allowable range, add a Repeater Unit and supply power from the Repeater Unit.

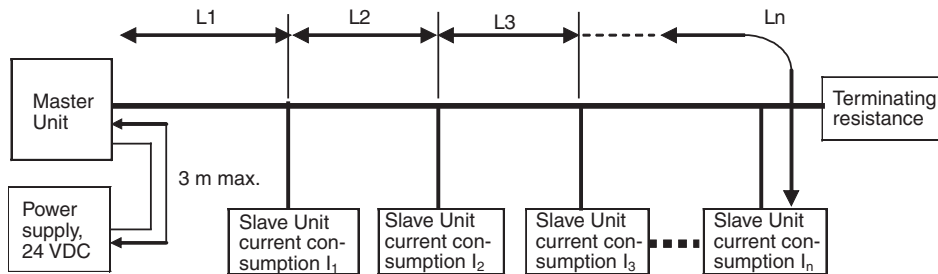

■ Calculation Example

The allowable power supply voltage range for Slave Units is 14 to 26.4 VDC. If a 24-VDC power supply is used, the allowable voltage drop is 10 V.

The relationship between the cable and the length that can be extended is expressed by the following formula:

$$10 (V) \geq \{(I_1 + I_2 + I_3 + \dots + I_n) \times R_1 \times L_1 \times 2\} + \{(I_2 + I_3 + \dots + I_n) \times R_2 \times L_2 \times 2\} + \{(I_3 + \dots + I_n) \times R_3 \times L_3 \times 2\} + \dots + \{I_n \times R_n \times L_n \times 2\}$$

To provide leeway when selecting the cable, use the following approximation.

$$10(V) \geq \{(I_1 + I_2 + I_3 + \dots + I_n) \times R \times L \times 2\}$$

R = Cable conductor resistance = 0.025 W/m for Flat Cable

The extended length of the cable is thus expressed by the following formula:

$$L (m) \leq 200 \div (I_1 + I_2 + I_3 + \dots + I_n) \dots \text{ For Flat Cable}$$

4-4-7 Precautions on Locating the I/O Power Supply

When building a system, the supply methods for communications power and I/O power must be considered. Not only hardware, such as selecting the power supplies and cables based on allowable currents and voltage drop, be considered, but also system operation for power supply errors, costs, and other software issues must be considered when studying power supply methods.

Supplying I/O Power from One Source

When supplying I/O power to the entire system from one source, the power consumed by each devices and the loads must be considered. Select the cables so that the power supply voltage for the last Slave Unit and load will be within the allowable range.

Also, give proper consideration to the power supply capacity and be sure the total line current is within the allowable current range of the cable.

The following measures can be considered to keep the voltage drop within the allowable range when supplying power from one power supply.

- Increase the thickness of the cables.
- Increase the output voltage of the power supply.
- Shorting the wiring.
- Locate the power supply in the middle of the network.

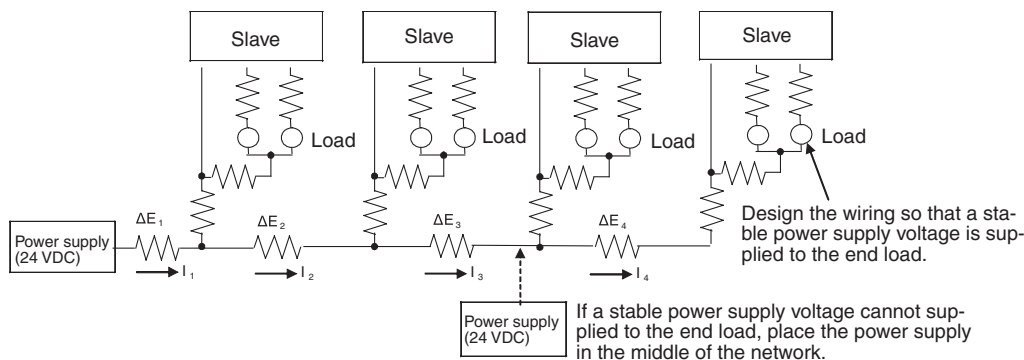

Supplying I/O Power from Multiple Sources

Supplying I/O power from multiple power supplies instead of from one power supply enables reducing the line current, reducing the voltage drop, and decreasing the size of the cable. Using multiple power supplies should also be considered to increase system safety when power supply errors occur.

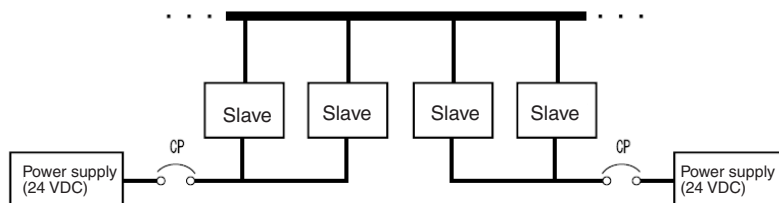

4-4-8 Other Precautions

Power Supply Errors

The location of power supplies and the grouping of Slave Units should be considered based on whether the overall system is to be stopped when a power supply error occurs.

If it is necessary to prevent the overall system from stopping to ensure system safety, consider placing power supplies in more than one location and consider the way Slave Units should be grouped when supplying power.

Cost Considerations

Also consider the power supply methods from the point of view of the total cost, including the following items:

- The capacity and number of power supplies, Cable thickness (allowable current) and length (voltage drop),
- System safety, and
- Wiring work.

4-5 Connecting External I/O for Slave Units

This section describes connecting external I/O to Slave Units.

4-5-1 Word Slave Units (CRT1-ID16(-1) and CRT1-OD16(-1))

Attach the following M3 crimp terminals to signal lines and then connect them to the terminal block.

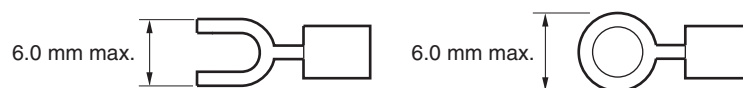

Note Tighten terminal block screws to a torque of 0.5 N·m.

4-5-2 Bit Slave Units

External I/O connections to Bit Slave Units are made using industrial standard sensor connectors (e-CON) and screw-less clamp terminal blocks. The external I/O connection method for each model is given in the following table.

Model	External I/O connection method
CRT1B-ID02S	Industrial standard sensor connector (e-CON)
CRT1B-ID02S-1	
CRT1B-OD02S	
CRT1B-OD02S-1	
CRT1B-ID02SP	
CRT1B-ID02SP-1	
CRT1B-OD02SP	
CRT1B-OD02SP-1	
CRT1B-ID04SP	
CRT1B-ID04SP-1	
CRT1B-MD04SLP	
CRT1B-MD04SLP-1	

Industrial Standard Sensor Connector (e-CON) Assembly, Wiring, and Installation

Input Bit Slave Units and Output Bit Slave Units use industry standard sensor connectors. When connecting a sensor or other external device, a special connector must be attached to the sensor or other external device cable.

OMRON XN2A-1430
Cable Connector

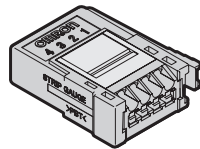

Use the following procedure to attach the Cable Connector to the sensor or other external device cable.

■ **Checking the Cable Connector and Cable Wire Size**

The applicable Cable Connector depends on the manufacturer and the wire size. Use the following table to check that the Cable Connector and sensor or other external device cable wire size are compatible.

Tyco Electronics Corporation

Model	Housing color	Applicable wire range
1-1473562-4	Red	AWG28 (0.08 mm ²) to AWG24 (0.2 mm ²), sheath outer diameter: 0.9 to 1.0 mm
1473562-4	Yellow	AWG24 (0.2 mm ²) to AWG22 (0.3 mm ²), sheath outer diameter: 1.0 to 1.15 mm
2-1473562-4	Blue	AWG22 (0.3 mm ²) to AWG20 (0.5 mm ²), sheath outer diameter: 1.15 to 1.35 mm

Sumitomo 3M

Model	Housing color	Applicable wire range
37104-3101-000FL	Red	AWG26 (0.14 mm ²) to AWG24 (0.2 mm ²), sheath outer diameter: 0.8 to 1.0 mm
37104-3122-000FL	Yellow	AWG26 (0.14 mm ²) to AWG24 (0.2 mm ²), sheath outer diameter: 1.0 to 1.2 mm
37104-3163-000FL	Orange	AWG26 (0.14 mm ²) to AWG24 (0.2 mm ²), sheath outer diameter: 1.2 to 1.6 mm
37104-2124-000FL	Green	AWG22 (0.3 mm ²) to AWG20 (0.5 mm ²), sheath outer diameter: 1.0 to 1.2 mm
37104-2165-000FL	Blue	AWG22 (0.3 mm ²) to AWG20 (0.5 mm ²), sheath outer diameter: 1.2 to 1.6 mm
37104-2206-000FL	Gray	AWG22 (0.3 mm ²) to AWG20 (0.5 mm ²), sheath outer diameter: 1.6 to 2.0 mm

OMRON

Model	Specifications	Applicable wire range
XN2A-1430	Spring clamp type	AWG28 (0.08 mm ²) to AWG20 (0.5 mm ²), sheath outer diameter: 1.5 mm max.

■ **Preparing the Sensor or other External Device Cables**

Using Tyco Electronics or Sumitomo 3M Connectors

The sensor and other external device cables for connector output with transistors are normally either semi-stripped or stripped, as shown in the following diagram.

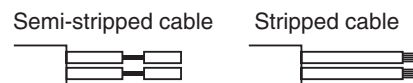

When the cables are prepared this way, a Cable Connector cannot be attached, so first cut the end and remove the cable sheath as shown in the following diagram. (Do not strip the core wires.)

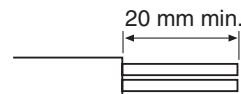

Using OMRON Connectors

Align the cable with the strip gauge on the side of the connector. Remove 7 to 8 mm of the wiring sheath, and twist the exposed wires several times.

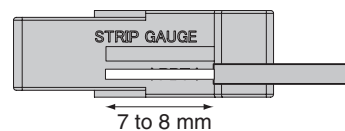

■ **Inserting the Wire into the Cable Connector (Hard Wiring Procedure)**

Using Tyco Electronics or Sumitomo 3M Connectors

- 1,2,3...**
1. Insert the wire into the cover of the Cable Connector. Check that the terminal number and wire color match, and insert all the way to the back of the connector.
 2. Join the cover and plug connector, using pliers or another tool to push in fully. At the same time, push in the middle of the cover straight so that it is not crooked.

Using OMRON Connectors

1,2,3...

1. Use a flat-blade screwdriver to push the operation lever inside the connector's operation opening until it locks, as shown in the following diagram.

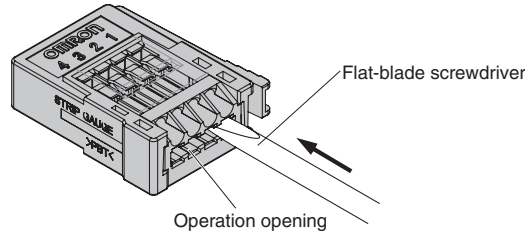

2. Insert the line all the way to the back of the wire insertion opening. Check that the sheath of the line is inserted into the wire insertion opening, and that the end of the conductor has passed through the connection part.

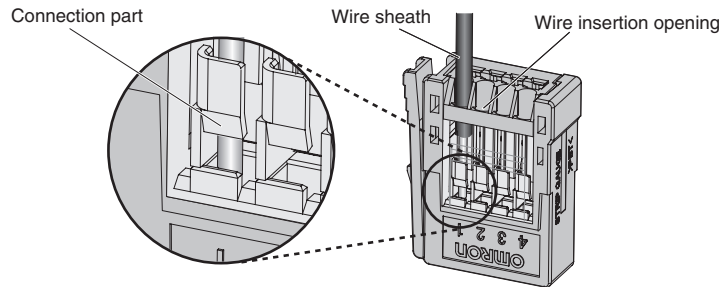

3. Insert a flat-blade screwdriver into the reset opening and pull back the lever lightly. A click will be heard and the operation lever will return to its normal position.

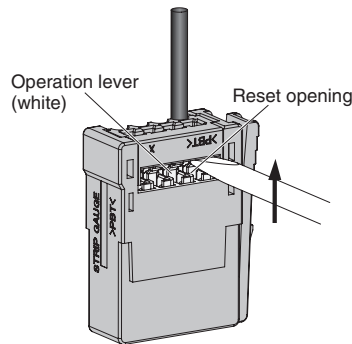

4. Check that the operation lever has returned to its position. Lightly pull on the lines, and if there is any resistance, they are connected properly.

Note

(1) When connecting a sensor, insert the wire so that the terminal number on the cover matches the sensor wire color, as shown in the following table.

	Using CRT1B-ID02S(P), CRT1B-ID04SP, CRT1B-MD04SLP		Using CRT1B-ID02S(P), CRT1B-ID04SP-1, CRT1B-MD04SLP-1	
Terminal number	3-wire sensor (without self-diagnostic output)	2-wire sensor (without self-diagnostic output)	3-wire sensor (without self-diagnostic output)	2-wire sensor (without self-diagnostic output)
1	Brown (red)	---	Brown (red)	Brown (white)
2	---	---	---	---
3	Blue (black)	Blue (black)	Blue (black)	---
4	Black (white)	Brown (white)	Black (white)	Blue (black)

(2) Wire colors have been changed according to revisions in the JIS standards for photoelectric and proximity sensors. The colors in parentheses are the wire colors prior to the revisions.

Note To remove a wire, push in the operation lever, check that the operation lever has locked, and then pull out the wire. After removing the wire, always return the operation lever to its normal position.

Wiring to Screw-less Clamp Terminal Blocks

The CRT1B-MD04SLP(-1) has a screw-less clamp terminal block. Screw-less clamp terminal blocks can be easily wired simply by placing pin terminals on the wires.

■ **Applicable Pin Terminals**

When wiring sensors or other external devices, pin terminals must be placed on the wires of the sensor or other external device.

The applicable pin terminals are listed in the following table.

Applicable wire size	Name	Crimp tool	Manufacturer
0.5 mm ² /AWG20	H0.5/14 orange	PZ6 roto	Weidmuller Co. Ltd.
0.75 mm ² /AWG18	H0.75/14 white		
1.5 mm ² /AWG16	H1.5/14 red		

Applicable Pin Terminal Conductor Length

The pin terminal conductor should be about 8 to 10 mm in length.

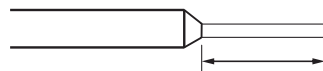

Conductor length: 8 to 10 mm

■ **Wiring to the Clamp Terminal Block**

Insertion

Insert the pin terminal all the way to the back of the terminal hole.

Removal

Press down the release button next to the terminal hole with a small flat-blade screwdriver and pull out the pin terminal while the release button is down.

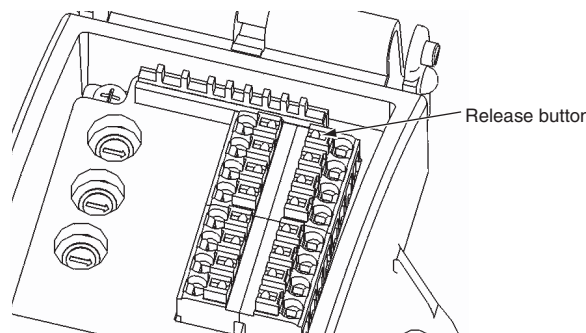

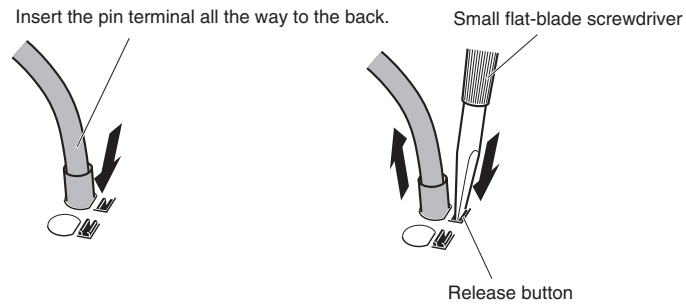

Note Press the release button with a force of 30 N or less. Applying excessive force may damage the clamp terminal block.

Use the following screwdriver when removing pin terminals.

Recommended Screwdriver

Model	Manufacturer
SD0.6 × 3.5 × 100 Flat-blade Screwdriver	Weidmuller Co. Ltd.

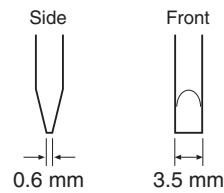

Connecting External I/O to Slave Units

This section describes connecting external I/O to IP54 Slave Units.

■ **Components**

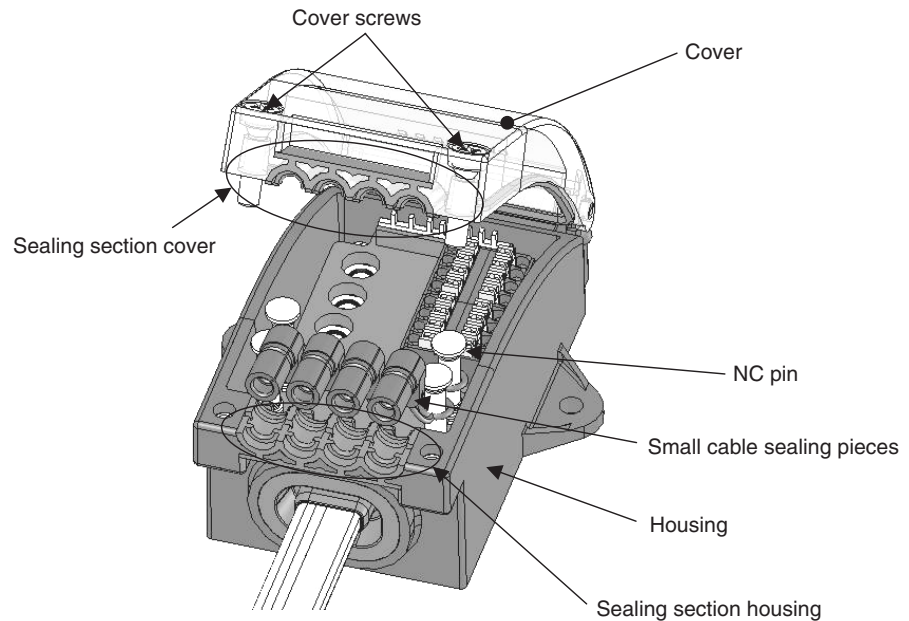

External I/O is connected to the clamp terminal block and industrial standard sensor connectors (e-CON) inside the housing. Connected external I/O cables are passed through the sealing.

The cables are held between the sealing section cover and sealing section housing to ensure resistance to splashing.

For cables with smaller outer diameters, the sealing pieces can be used to ensure splash resistance.

■ **Confirming Cable Size**

The range of cable outer diameters that are applicable to the sealing section is 2.2 to 6.3 mm.

The method for maintaining splash resistance at the sealing section depends on the size of cable that is being used.

Cable outer diameter	Small cable sealing piece
2.2 to less than 3.6 mm	Required.
3.6 to 6.3 mm	Not required.

Using the Small Cable Sealing Pieces

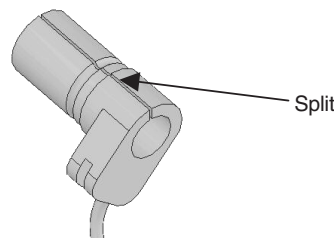

Expand the split in the sealing piece and insert the cable.

Place the groove on the sealing pieces onto the inside of the housing to secure it. (See following diagram.)

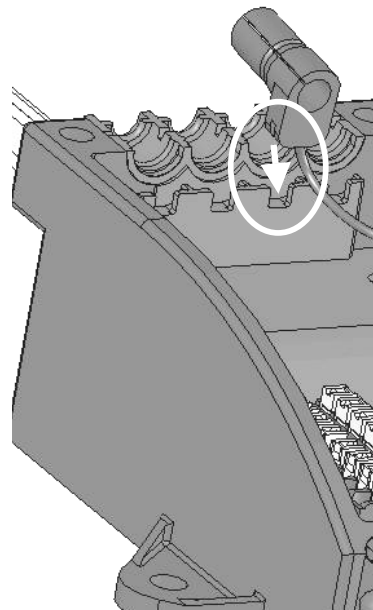

■ **Handling Unconnected Terminals**

For terminals that are not connected, insert an NC pin into the small cable sealing piece as shown in the following diagram. Then secure the sealing piece onto the housing as described above.

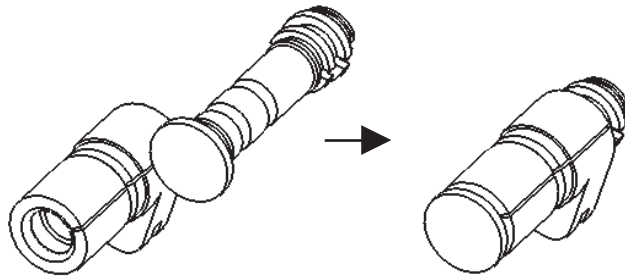

■ **Tightening the Cover**

Finally, tighten the cover screws.
The tightening torque is 0.8 to 1.0 N·m.

SECTION 5

Remote I/O Communications

This section describes the remote I/O communications that are possible with CompoNet Networks.

5-1	Exchanging Data with the CPU Unit	120
5-1-1	Basic Communications Operations.	120
5-1-2	Start and Stop Conditions for Remote I/O Communications	120
5-1-3	Communications Errors	120
5-1-4	Addresses Allocated to Slave Units	121
5-1-5	Slave Unit Normal Confirmation	123
5-2	Allocations to Slave Units.	129
5-2-1	Overview.	129
5-2-2	I/O Memory Area Allocations by Communications Mode Number	129
5-2-3	Types of Node Addresses in CompoNet Networks	135
5-2-4	Details of Slave Unit Allocation in I/O Memory	137
5-2-5	Status Area Allocation	146
5-3	Remote I/O Communications Performance	156
5-3-1	I/O Response Time	156
5-3-2	Effects of Master Units on CPU Unit Cycle Time	165

5-1 Exchanging Data with the CPU Unit

5-1-1 Basic Communications Operations

Communications for sharing data can be continuously performed between the CPU Unit and Slave Units. This is called “remote I/O communications.”

- Communications are started just by connecting the communications wiring and turning ON the power (the communications power supply to the Slave Unit and the power supply to the PLC), allowing data to be shared between the I/O Memory Areas of the CPU Unit and the Slave Unit.
- The ladder program is used to read and write the areas where data is shared (i.e., the areas allocated to Slave Units). When reading and writing shared data, use the normal operation of the Slave Unit as a condition for the read/write operation.

5-1-2 Start and Stop Conditions for Remote I/O Communications

- Remote I/O communications start when power is turned ON to the PLC and the Slave Unit communications power is turned ON. When the Registered Slave Unit Participation Standby Mode is enabled, however, remote I/O communications will not start until all registered Slave Units are participating.
- Remote I/O communications can also be started using a FINS command.
- When I/O Communications Manual Startup Mode is set from the CompoNet Support Software, remote I/O communications are not started when the power is turned ON. Remote I/O communications will not start until the Remote I/O Communications Start Switch is turned ON in memory.
- In Communications Error Communications Stop Mode, all remote I/O communications will be stopped if a communications error occurs in any Slave Unit. When that happens, the Communications Error Communications Stop Flag (status bit 02) turns ON. The ESTP (Communications Error Communications Stop Mode) DIP switch pin on the front of the CompoNet Master Unit must be turned ON.

Note Communications will not stop for verification errors for registration tables or duplicated Slave Unit address settings.

5-1-3 Communications Errors

A communications error exists when a Slave Unit cannot return a normal response to a communications request from a Master Unit. The following are the main causes of communications errors:

- There is a malfunction at the Slave Unit itself.
- There is a disconnection in a communications cable to the Slave Unit.
- The communications power supply is OFF.
- The affected Slave Unit cannot receive correct data because of noise.

When a communication error occurs at a Slave Unit, the NS indicator on the front of the Master Unit will light and *d9* will be displayed on the seven-segment display. At the same time, the relevant Communications Error Flag (status bit 00) will turn ON.

Remote I/O Communications Operation When a Communications Error Occurs

If ESTP (Communications Error Communications Stop Mode) is turned ON on the DIP switch on the front of the Master Unit, all remote I/O communications will stop when a communications error occurs at any Slave Unit. (The Communications Error Communications Stop Flag at status bit 02 also will turn ON.) If ESTP is set to OFF, remote I/O communications continue.

When the cause of the communications error is removed, the Slave Unit is automatically restored in the network. There is no need to restart or to cycle the power to the Master Unit.

Communications Error Input Data Zero Clear Mode

Input Data Zero Clear Mode can be set from the CompoNet Support Software for communications errors. If a communications error occurs for a Slave Unit in this mode, all input data for that Slave Unit is cleared to zeros. If Input Data Zero Clear Mode is not set, then the input data is held for the Slave Unit even if a communications error occurs. This can be used, for example, to suppress triggering operations when communications errors have occurred in systems where ON input data signals are used as triggers for operation.

5-1-4 Addresses Allocated to Slave Units

- Each Slave Unit is allocated memory in the Special I/O Unit area of the CIO Area (CIO 2000 to CIO 2959) in the CPU Unit, in order of node address (fixed) and from the following beginning address. (See note.)

Beginning address: $\text{CIO } 2000 + (10 \times \text{unit number})$

(The “unit number” is the number by which the CPU Unit identifies Special I/O Units (from 0 to 95). It is set on the rotary switch on the front of the Master Unit.)

Note When the communications mode number is set to 8 (software setting), the first address can be set to any address in the CPU Unit's CIO, WR, HR, or DM Area). (The number of allocated nodes can also be specified.) Even in this case, however, the node address order is fixed.

- The area after the Output Area (the area allocated to Output Slave Units) is the Input Area (the area allocated to Input Slave Units). Within each of these areas, the allocated addresses are determined in ascending order of node addresses.

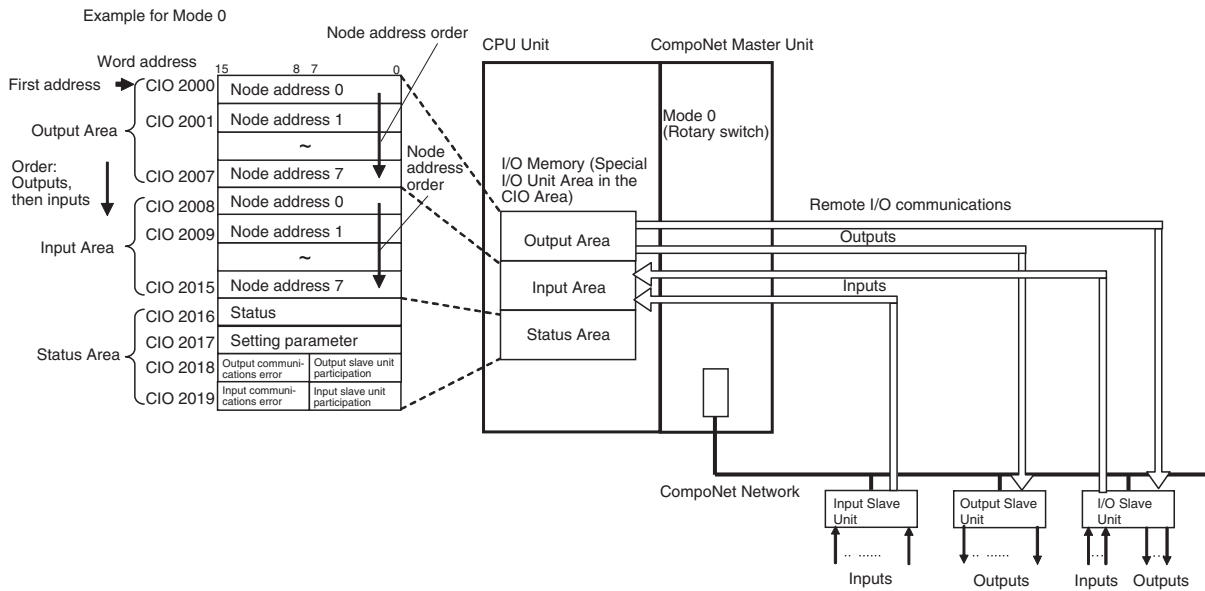

- The Input Area is allocated to Input Slave Units, the Output Area is allocated to Output Slave Units, and both the Input Area and the Output Area are allocated to Mixed I/O Slave Units.

The 16 Slave Unit inputs for node address N are allocated in one word (bits 00 to 15) at node address N in the Input Area.

The 16 Slave Unit outputs for node address N are allocated in one word (bits 00 to 15) at node address N in the Output Area.

The 16 Slave Unit inputs and 16 Slave Unit outputs for node address N are allocated in one word (bits 00 to 15) plus one word (bits 00 to 15) at node address N in the Input Area and node address N in the Output Area.

Allocation Example

Example for Mode 0

I/O Memory (Allocated in the Special I/O Unit Area in the CIO Area)

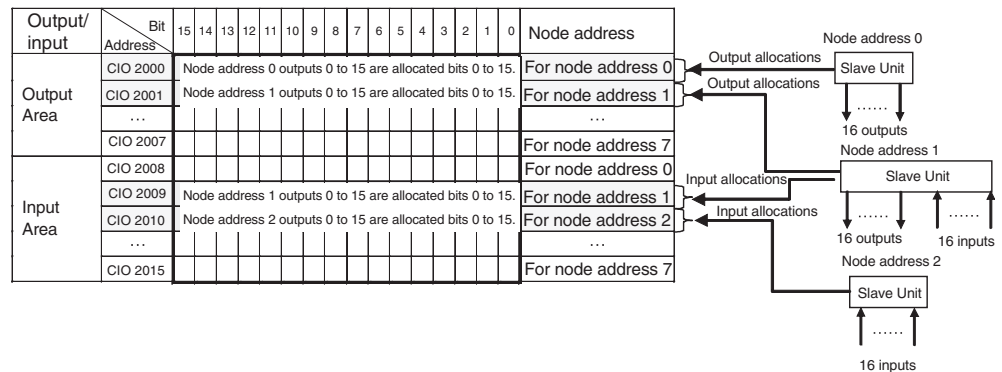

- For node requiring only 8 inputs or 8 outputs, the node is allocated the rightmost byte of the respective word (bits 00 to 07). The leftmost byte (bits 08 to 15) is not used.

Note When this manual was printed, only Expansion Units have 8 inputs and 8 outputs.

- If there are more than 16 Slave Unit inputs or outputs, both the node address and the next node address (+1) are allocated.

If 16 Slave Unit inputs at node address N are expanded by 8 inputs to make a total of 24 inputs, then Input Area node address N and node address N+1 are allocated.

Note If there are no Slave Unit inputs for node address N+1, there will be no node address duplication error for node address N+1. If there are Slave Unit inputs for node address N+1, a node address duplication error will occur.

If 16 Slave Unit outputs at node address N are expanded by 8 outputs to make a total of 24 outputs, then Output Area node address N and node address N+1 are allocated.

Note If there are no Slave Unit outputs for node address N+1, there will be no node address duplication error for that N+1. If there are Slave Unit outputs for node address N+1, a node address duplication error will occur.

Allocation Example

Example for Mode 0

I/O Memory (Allocated in the Special I/O Unit Area in the CIO Area)

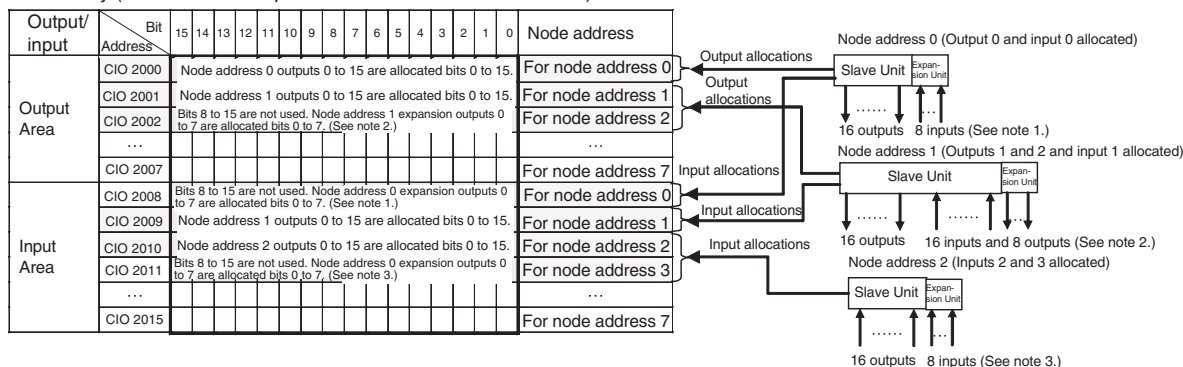

- Note**
- (1) The 8 expansion inputs for node address 0 are allocated bits 00 to 07 of CIO 2008 for node address 0. (Bits 08 to 15 are not used.)
 - (2) The 8 expansion outputs for node address 1 are allocated bits 00 to 07 of CIO 2002 for node address 2, following node address 1. (Bits 08 to 15 of CIO 2002 are not used.)
 - (3) The 8 expansion inputs for node address 2 are allocated bits 00 to 07 of CIO 2011 for node address 3, following node address 2. (Bits 08 to 15 of word 2011 are not used.)

5-1-5 Slave Unit Normal Confirmation

Participation and Communications Error Flags

- Participation Flags and Communications Error Flags in the Status Area (the area allocated after the I/O allocations) are used to indicate whether Slave Units are participating normally in the network.
 - Participation Flags

A Participation Flag turns ON once the corresponding Slave Unit starts participating in the network when the System is started (i.e., when the power is turned ON). It remains ON even if the Slave Unit stops participating due to a communications error.

• Communications Error Flags

A Communications Error Flag turns ON if the applicable Slave Unit cannot communicate with the Master Unit for any reason after the Slave Unit has joined the network (i.e., if the Participation Flag is ON). It turns OFF when the error is removed.

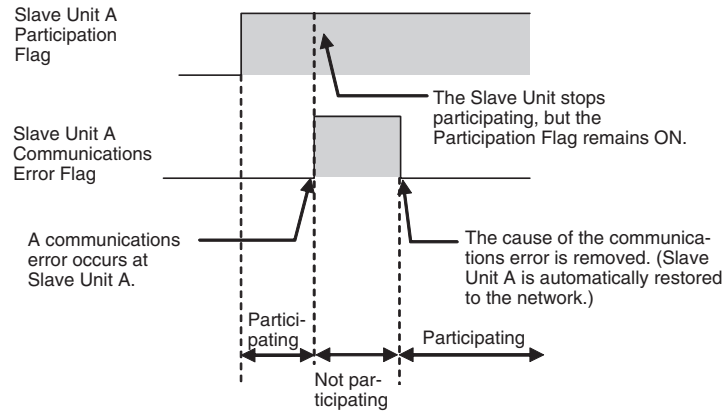

Therefore, in the ladder program, the applicable Slave Unit has stopped participating when both the Participation Flag and the Communications Error Flag are ON. Similarly, the applicable Slave Unit is operating normally when the Participation Flag is ON and the Communications Error Flag is OFF.

Example: This example shows the executing I/O with the applicable Slave Unit when the Participation Flag and Communications Error Flag are combined and taken as a condition to confirm that operation is normal.

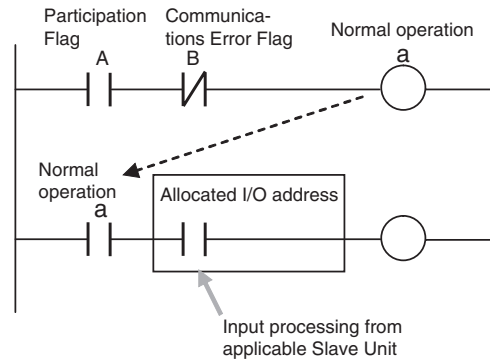

- The operation of the Participation Flags and Communications Error Flags depends on the status of SW4 (REGS) on the DIP switch on the front of the Master Unit.

SW (REGS) of DIP switch on front of Master Unit	Object of Participation or Communications Error Flag
OFF (Registration Table Disabled)	All Slave Units
ON (Registration Table enabled)	Registered Slave Units only. Participation Flags and Communications Error Flags for unregistered Slave Units do not operate.

- A bit is allocated for each node address. The 8 input nodes are allocated after the 8 output nodes.

Note When there are both inputs and outputs (i.e., for I/O Slaves), flags are allocated only for the input node.

- Participation Flags are allocated the rightmost byte (bits 00 to 07). Inputs are allocated after outputs.
- Communications Error Flags are allocated the leftmost byte (bits 08 to 15).

Example for Mode 0

I/O Memory (Allocated in the Special I/O Unit Area in the CIO Area)

Communications Error Flags for nodes 0 to 7, both inputs and outputs, are allocated bits 8 to 15. Participation Flags for nodes 0 to 7, both inputs and outputs, are allocated bits 0 to 7.

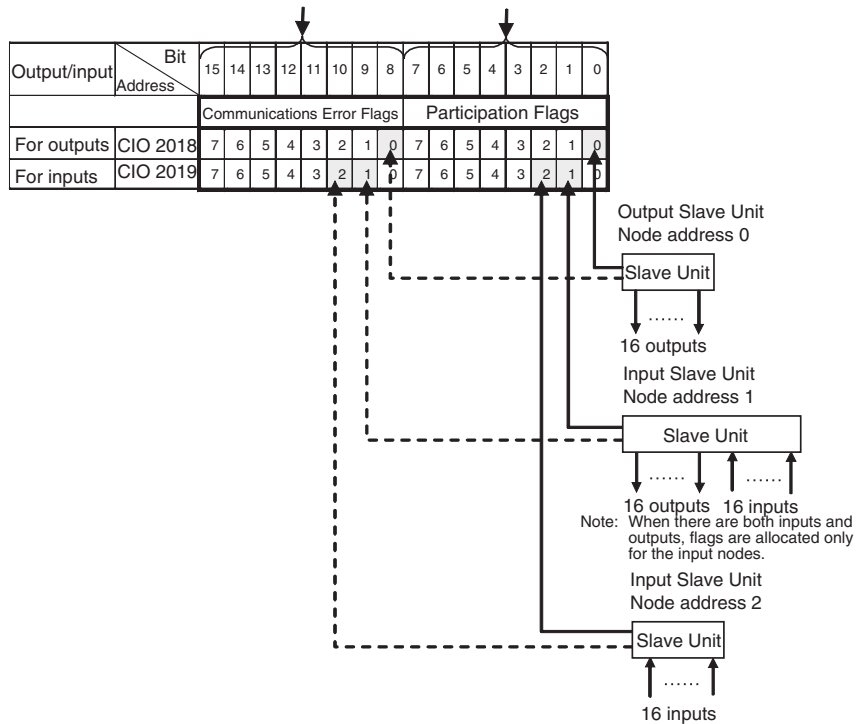

Registration Tables

Overview

Registration Tables are used to register Slave Units that are intended to participate at particular node addresses (along with the models corresponding to the node addresses) to enable verifying that they actually are participating. At the same time, they prevent unregistered Slave Units and Slave Units of the wrong models from participating in the network.

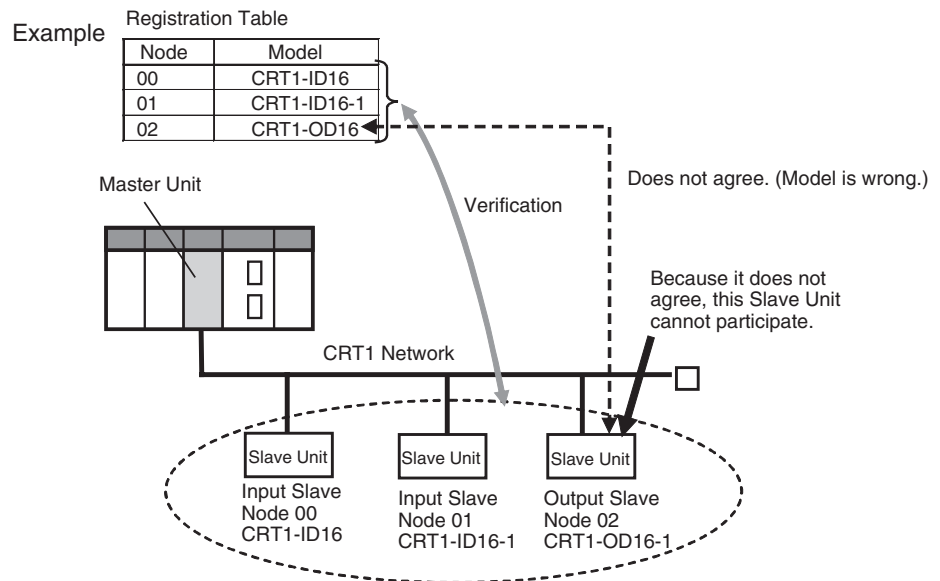

This function is enabled only in Registration Table Enable Mode, i.e., when SW4 (REGS) is turned ON on the Master Unit when the power is turned ON and the Registration Table data is normal). It can be used with any communications mode number.

If a Slave Unit is found to be not in agreement during the verification, the Registration Table Verification Error Flag (status bit 01) will turn ON. Remote I/O communications will still start, if the Registered Slave Unit Participation Standby Mode is disabled. If the Registered Slave Unit Participation Standby Mode is enabled, remote I/O communications will not start.

Operation

The operation for each case is as follows:

- If all registered Slave Units are participating within the Registered Slave Unit Participation Monitoring Time after the power is turned ON (or after the Remote I/O Communications Start Switch is turned ON), the All Registered Slave Units Participating Flag (status bit 06) will turn ON. (The default monitoring time is 10 s for any baud rate other than 93.75 kbits/s, and 30 s for 93.75 kbits/s. Also see note 1.) In this case:
 - If no unregistered Slave Units are participating, the Registration Table Verification Error Flag will turn OFF.
 - If any unregistered Slave Unit is participating, a verification error (unregistered Slave Unit) will occur and the Registration Table Verification Error Flag will turn ON. At the same time, the NS indicator on the front of the Master Unit will flash red and the seven-segment display will show *d6*.
- If all registered Slave Units are not participating within the Registered Slave Unit Participation Monitoring Time after the power is turned ON (or after the Remote I/O Communications Start Switch is turned ON when the Remote I/O Communications Manual Start Mode is enabled), a verification error (non-existent Slave Unit) will occur and the Registration Table Verification Error Flag will turn ON. (The default monitoring time is 10 s for any baud rate other than 93.75 kbit/s, and 30 s for 93.75 kbit/s. Also see note 1.) At the same time, the NS indicator on the front of the Master Unit will flash red and the seven-segment display will show *d5*. If the applicable Slave Unit subsequently starts participating, the Registration Table Verification Error Flag will turn OFF and the error display will be cleared.

Note (a) The Registered Slave Participation Monitoring Time is disabled when the Registered Slave Participation Standby Mode is enabled.

(b) Remote I/O communications will not operate if SW4 (REGS) is ON on the Master Unit when the power is turned ON and the Registration Table data is not valid. The MS indicator on the front of the Master Unit will flash red, and the seven-segment display will show *E8*.

Creating Registration Tables

Registration Tables are created either by automatic generation from the CompoNet Support Software or by editing and transferring them.

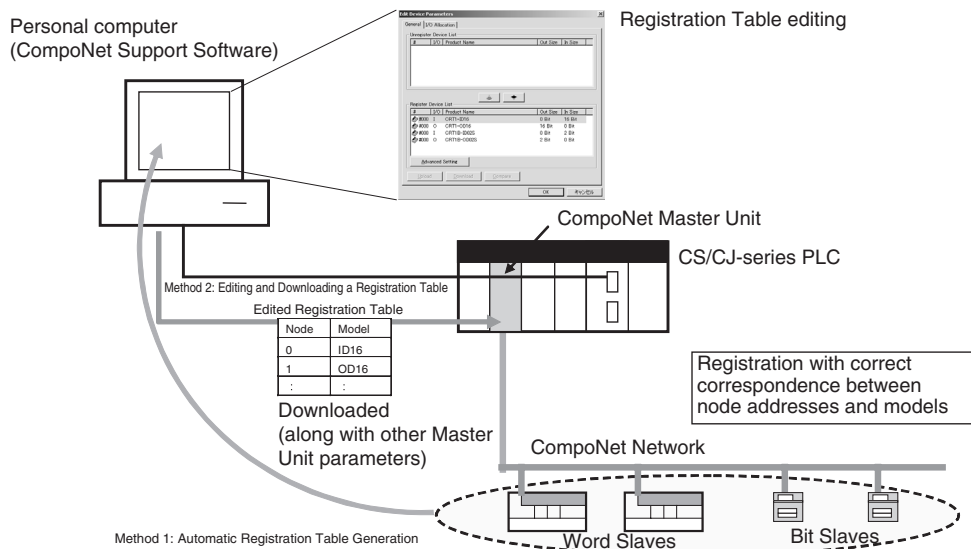

The Registration Table is then enabled by turning ON the power with SW4 (REGS) on the Master Unit turned ON. (The Registration Table is read when the power is turned ON.) The Registration Table Mode Flag (status bit 10) will turn ON (Registration Table Enable Mode).

1) Automatic Registration Table Generation

Click the **Auto Generate Registration Table** Button to automatically generate a Registration Table (node addresses corresponding to models) based on the actual configuration of participating Slave Units with no communications errors.

2) Editing and Transferring a Registration Table

Use the CompoNet Support Software to edit a Registration Table (node addresses corresponding to models) in the Master Parameter Edit Window, and then download it to the CompoNet Master Unit.

Note Registration Tables that are either generated automatically from the CompoNet Support Software or edited and downloaded are stored in EEPROM in the CompoNet Master Unit. Therefore the Registration Table data in the CompoNet Master Unit is saved even if the PLC power is turned OFF or if the Master Unit is mounted to another PLC.

Registered Slave Participation Monitoring Time

The Registered Slave Participation Monitoring Time is the time from when the power is turned ON (or from when the Remote I/O Communications Start Switch is turned ON when the Remote I/O Communications Manual Start Mode is enabled) until it is judged that all registered Slave Units are participating. The Registered Slave Participation Monitoring Time can be set to a time other than the default (10 s for any baud rate other than 93.75 kbit/s, and 30 s for 93.75 kbit/s).

Using the CompoNet Support Software, set the Registered Slave Participation Monitoring Time (1 to 600 s; default: 10 s at baud rate of other than 93.75 kbit/s and 30 s at baud rate of 93.75 kbit/s) under *Detailed Settings* in the Master General Tab Page, and then downloading the parameters to the CompoNet Master Unit. This setting is disabled when the Registered Slave Participation Standby Mode is enabled.

Registered Slave Participation Standby Mode

Registered Slave Participation Standby Mode can be used to not start remote I/O communications until all registered Slave Units are participating in the network (i.e., while the All Registered Slaves Participating Flag is OFF). Remote I/O communications will start when the All Registered Slaves Participating Flag turns ON. Using this mode will make it faster for all Slave Units to participate in the network.

Remote I/O communications will not start, however, unless all registered Slave Units are participating.

When this mode is used, Registered Slave Unit Participation Monitoring Time setting (including the default value of 10 s) is disabled.

Using CompoNet Support Software, enable the Registered Slave Participation Standby Mode under *Detailed Settings* in the Master General Tab Page, and download the parameters to the CompoNet Master Unit.

This function is enabled only in Registration Table Enable Mode, i.e., when SW4 (REGS) is turned ON on the Master Unit when the power is turned ON, and the Registration Table data is normal. It can be used with any communications mode number.

Slave Unit Address Duplication Error

In any of the following cases, a Slave Unit address duplication error will occur and the Address Duplication Error Flag (status bit 03) will turn ON for the Slave Unit that joined the network later. The NS indicator on the front of the Master Unit will flash red and the seven-segment display will show d0. Remote I/O communications will stop.

- There is already a Slave Unit for which the same node address is set. (For example, both Slave Units are set for node address N.)

Note An address duplication error will occur when two Slave Units are set for the same node address even if one of them is an Input Slave Unit and the other is an Output Slave Unit.

- Different node addresses are set, but the allocated memory areas overlap. (For example, a Slave Unit set for node address 0 has 24 inputs and a Slave Unit set for node address 1 has 16 inputs, in which case both Slave Units will be set to use the Input 1 Area.)

Note As long as the allocated areas themselves are not duplicated between nodes, Slave Units set for different node addresses can be allocated the Input Area and Output Area at the same node address area. (For example, a Slave Unit set for node address 1 can be allocated 16 outputs in the Output 1 Area, while an Expansion Slave Unit set for node address 0 can be allocated 16 inputs in the Input 1 Area.)

- A Slave Unit was removed and then a Slave Unit of a different class started participating at the same node address.

Illegal Configuration Error

If the permitted number of Repeater Unit segments is exceeded, the NS indicator on the front of the Master Unit will flash red and the seven-segment display will show *E5*.

5-2 Allocations to Slave Units

This section describes how Slave Unit I/O is allocated in the I/O Memory of the CPU Unit under which the CompoNet Master Unit is mounted.

5-2-1 Overview

Portions of the Special I/O Unit Area or an area set using the CompoNet Support Software in the CPU Unit under which the Master Unit is mounted are allocated to Slave Unit I/O information and status information.

The words that are allocated are determined by the unit number of the Master Unit as a Special I/O Unit and the communications mode number (or according to software settings made using the CompoNet Support Software when communications mode 8 is set), and the bits used by each Slave Unit are determined by the node address set for the Slave Units and by the number of points used by the Slave Units.

5-2-2 I/O Memory Area Allocations by Communications Mode Number

Set the communications mode number according to the number of Slave Units connected (Word and Bit Slave Units) and the number of control points. Set 0 to 3 or 8 on the rotary switch on the front of the CompoNet Master Unit.

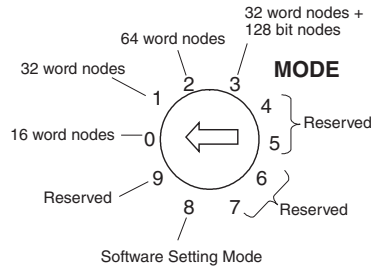

Number of Connectable Slave Unit Nodes and Control Points per Master Unit, and Memory Area Size for Each Mode

Com-muni-cations mode	Mode name	Allowable Slave Unit node addresses per Master Unit	Control points per Master Unit	Unit num-bers per Master Unit	Allocated area	Words allocated in I/O Memory				
						Output Area	Input Area	Status	Parameter settings	Participa-tion Flags and Com-muni-cations Error Flags
0	Communi-cations mode 0	Word Slave Units: 8 input and 8 output node addresses	Word Slave Units: 128 inputs and 128 outputs	2	Special I/O Unit Area	Word Slave Units: 8 words	Word Slave Units: 8 words	1 word	1 word	Word Slave Units: 2 words
1	Communi-cations mode 1	Word Slave Units: 16 input and 16 output node addresses	Word Slave Units: 256 inputs and 256 outputs	4		Word Slave Units: 16 words	Word Slave Units: 16 words	1 word	1 word	Word Slave Units: 4 words
2	Communi-cations mode 2	Word Slave Units: 32 input and 32 output node addresses	Word Slave Units: 512 inputs and 512 outputs	8		Word Slave Units: 32 words	Word Slave Units: 32 words	1 word	1 word	Word Slave Units: 8 words
3	Communi-cations mode 3	Word Slave Units: 16 input and 16 output node addresses Bit Slave Units: 64 input and 64 output node addresses	Word Slave Units: 256 inputs and 256 outputs Bit Slave Units: 128 inputs and 128 outputs	8		Word Slave Units: 16 words + Bit Slave Units: 8 words	Word Slave Units: 16 words + Bit Slave Units: 8 words	1 word	1 word	Word Slave Units: 4 words + Bit Slave Units: 16 words
8	Soft-ware Setting Mode	Word Slave Units: 64 input and 64 output node addresses Bit Slave Units: 128 input and 128 output node addresses	Word Slave Units: 1,024 inputs and 1,024 outputs Bit Slave Units: 256 inputs and 256 outputs	1	The first address can be set for Word Slave Unit outputs, Word Slave Unit inputs, Bit Slave Unit outputs, and Bit Slave Unit inputs. (Can be allocated in the CIO, WR, HR, or DM Area using a software setting from the CompoNet Support Software.)	Word Slave Units: 64 words + Bit Slave Units: 16 words max. (Soft-ware setting from the Compo-Net Support Software.)	Word Slave Units: 64 words + Bit Slave Units: 16 words max. (Soft-ware setting from the Compo-Net Support Software.)	1 word	1 word	Word Slave Units: 16 bits +Bit Slave Units: 32 bits

Note The two words for status and parameter settings are allocated in the Special I/O Unit Area.

I/O Memory Size and Allocation Patterns for Each Communications Mode

Allocation Patterns

Communications mode number	Pattern										
0	<p>Special I/O Unit Area</p> <table border="1" style="width: 100%;"> <tr> <td style="width: 20%;">Words +0 to +7</td> <td>Output data (8 words) Word Slave Unit outputs 0 to 7</td> </tr> <tr> <td>Words +8 to +15</td> <td>Input data (8 words) Word Slave Unit inputs 0 to 7</td> </tr> <tr> <td>Word +16</td> <td>Status (1 word)</td> </tr> <tr> <td>Word +17</td> <td>Parameter settings (1 word)</td> </tr> <tr> <td>Words +18 to +19</td> <td>Participation Flags and Communications Error Flags (2 words)</td> </tr> </table>	Words +0 to +7	Output data (8 words) Word Slave Unit outputs 0 to 7	Words +8 to +15	Input data (8 words) Word Slave Unit inputs 0 to 7	Word +16	Status (1 word)	Word +17	Parameter settings (1 word)	Words +18 to +19	Participation Flags and Communications Error Flags (2 words)
Words +0 to +7	Output data (8 words) Word Slave Unit outputs 0 to 7										
Words +8 to +15	Input data (8 words) Word Slave Unit inputs 0 to 7										
Word +16	Status (1 word)										
Word +17	Parameter settings (1 word)										
Words +18 to +19	Participation Flags and Communications Error Flags (2 words)										

Communications mode number	Pattern							
1	Special I/O Unit Area Words +0 to +15 Words +16 to +31 Word +32 Word +33 Words +34 to +37 Words +38 to +39	<table border="1"> <tr> <td data-bbox="896 268 938 353">Output data (16 words) Word Slave Unit outputs 0 to 15</td> </tr> <tr> <td data-bbox="896 357 938 463">Input data (16 words) Word Slave Unit inputs 0 to 15</td> </tr> <tr> <td data-bbox="896 468 938 500">Status (1 word)</td> </tr> <tr> <td data-bbox="896 504 938 536">Parameter settings (1 word)</td> </tr> <tr> <td data-bbox="896 540 938 646">Participation Flags and Communications Error Flags (4 words)</td> </tr> <tr> <td data-bbox="896 651 938 715">Not used (2 words)</td> </tr> </table>	Output data (16 words) Word Slave Unit outputs 0 to 15	Input data (16 words) Word Slave Unit inputs 0 to 15	Status (1 word)	Parameter settings (1 word)	Participation Flags and Communications Error Flags (4 words)	Not used (2 words)
Output data (16 words) Word Slave Unit outputs 0 to 15								
Input data (16 words) Word Slave Unit inputs 0 to 15								
Status (1 word)								
Parameter settings (1 word)								
Participation Flags and Communications Error Flags (4 words)								
Not used (2 words)								
2	Special I/O Unit Area Words +0 to +31 Words +32 to +63 Word +64 Word +65 Words +66 to +73 Words +74 to +79	<table border="1"> <tr> <td data-bbox="896 785 938 891">Output data (32 words) Word Slave Unit outputs 0 to 31</td> </tr> <tr> <td data-bbox="896 895 938 1002">Input data (32 words) Word Slave Unit inputs 0 to 31</td> </tr> <tr> <td data-bbox="896 1006 938 1038">Status (1 word)</td> </tr> <tr> <td data-bbox="896 1042 938 1074">Parameter settings (1 word)</td> </tr> <tr> <td data-bbox="896 1078 938 1185">Participation Flags and Communications Error Flags (8 words)</td> </tr> <tr> <td data-bbox="896 1189 938 1295">Not used (6 words)</td> </tr> </table>	Output data (32 words) Word Slave Unit outputs 0 to 31	Input data (32 words) Word Slave Unit inputs 0 to 31	Status (1 word)	Parameter settings (1 word)	Participation Flags and Communications Error Flags (8 words)	Not used (6 words)
Output data (32 words) Word Slave Unit outputs 0 to 31								
Input data (32 words) Word Slave Unit inputs 0 to 31								
Status (1 word)								
Parameter settings (1 word)								
Participation Flags and Communications Error Flags (8 words)								
Not used (6 words)								

Communications mode number	Pattern
3	Special I/O Unit Area
	Words +0 to +15 Output data (16 words) Word Slave Unit outputs 0 to 15
	Words +16 to +31 Input data (16 words) Word Slave Unit inputs 0 to 15
	Words +32 to +39 Bit output data (8 words) Bit Slave Unit outputs: 0 to 63
	Words +40 to +47 Bit input data (8 words) Bit Slave Unit inputs: 0 to 63
	Word +48 Status (1 word)
	Word +49 Parameter settings (1 word)
	Words +50 to +53 Participation Flags and Communications Error Flags (4 words)
	Words +54 to +69 Bit Slave Participation Flags and Communications Error Flags (16 words)
	Words +70 to +79 Not used (10 words)

Communications mode number	Pattern																
8	<p>The first addresses for Word Slave input and output data, Bit Slave bit input and output data, and status data (status, settings, participation, and disconnection) are set using software settings (areas and addresses) from the CompoNet Support Software. The sizes allocated are also set using software settings (number of nodes) from the CompoNet Support Software.</p> <p>Note Words are always allocated to Slave Units in ascending order from node address 0. Nothing can be allocated to unused node addresses. If the number of nodes set from the CompoNet Support Software is n, then Slave Units are allocated from node address 0 to n-1.</p> <table border="1" data-bbox="890 549 1422 640"> <tr> <td data-bbox="778 549 890 640">Words +0 to +63 max.</td> <td data-bbox="890 549 1422 640">Output data (64 words max.) Slave Unit outputs: 0 to 63</td> </tr> </table> <table border="1" data-bbox="890 672 1422 763"> <tr> <td data-bbox="778 672 890 763">Words +0 to +63 max.</td> <td data-bbox="890 672 1422 763">Input data (64 words max.) Slave Unit inputs: 0 to 63</td> </tr> </table> <table border="1" data-bbox="890 795 1422 887"> <tr> <td data-bbox="778 795 890 887">Words +0 to +15 max.</td> <td data-bbox="890 795 1422 887">Bit output data (16 words max.) Bit Slave Unit outputs: 0 to 127</td> </tr> </table> <table border="1" data-bbox="890 919 1422 1010"> <tr> <td data-bbox="778 919 890 1010">Words +0 to +15 max.</td> <td data-bbox="890 919 1422 1010">Bit input data (16 words max.) Bit Slave Unit inputs: 0 to 127</td> </tr> </table> <table border="1" data-bbox="890 1042 1422 1134"> <tr> <td data-bbox="778 1042 890 1134">Words +0 to +15 max.</td> <td data-bbox="890 1042 1422 1134">Participation Flags and Communications Error Flags (16 words)</td> </tr> </table> <table border="1" data-bbox="890 1166 1422 1257"> <tr> <td data-bbox="778 1166 890 1257">Words +0 to +31</td> <td data-bbox="890 1166 1422 1257">Bit Slave Participation Flags and Communications Error Flags (32 words)</td> </tr> </table> <p>The following items are allocated in the Special I/O Unit Area.</p> <table border="1" data-bbox="890 1336 1422 1406"> <tr> <td data-bbox="852 1336 890 1370">+0</td> <td data-bbox="890 1336 1422 1370">Status (1 word)</td> </tr> <tr> <td data-bbox="852 1370 890 1406">+1</td> <td data-bbox="890 1370 1422 1406">Parameter settings (1 word)</td> </tr> </table>	Words +0 to +63 max.	Output data (64 words max.) Slave Unit outputs: 0 to 63	Words +0 to +63 max.	Input data (64 words max.) Slave Unit inputs: 0 to 63	Words +0 to +15 max.	Bit output data (16 words max.) Bit Slave Unit outputs: 0 to 127	Words +0 to +15 max.	Bit input data (16 words max.) Bit Slave Unit inputs: 0 to 127	Words +0 to +15 max.	Participation Flags and Communications Error Flags (16 words)	Words +0 to +31	Bit Slave Participation Flags and Communications Error Flags (32 words)	+0	Status (1 word)	+1	Parameter settings (1 word)
Words +0 to +63 max.	Output data (64 words max.) Slave Unit outputs: 0 to 63																
Words +0 to +63 max.	Input data (64 words max.) Slave Unit inputs: 0 to 63																
Words +0 to +15 max.	Bit output data (16 words max.) Bit Slave Unit outputs: 0 to 127																
Words +0 to +15 max.	Bit input data (16 words max.) Bit Slave Unit inputs: 0 to 127																
Words +0 to +15 max.	Participation Flags and Communications Error Flags (16 words)																
Words +0 to +31	Bit Slave Participation Flags and Communications Error Flags (32 words)																
+0	Status (1 word)																
+1	Parameter settings (1 word)																

Unit Number Allocations

Allocating One Unit Number per Node (Communications Mode 8)

CIO 2000 + (10 × Unit No.) to CIO 2009 + (10 × unit No.): Unit No. = 0 to 95)

First allocated word	Unit number setting
CIO 2000	Unit No. 0
CIO 2010	Unit No. 1
CIO 2020	Unit No. 2
CIO 2030	Unit No. 3
CIO 2040	Unit No. 4
CIO 2050	Unit No. 5
:	
CIO 2940	Unit No. 94
CIO 2950	Unit No. 95

Allocating Two Unit Numbers per Node (Communications Mode 0)

CIO 2000 + (10 × unit No.) to CIO 2019 + (10 × unit No.): Unit No. = 0 to 94

First allocated word	Unit number setting	
CIO 2000	Unit No. 0	
CIO 2010		Unit No. 1
CIO 2020	Unit No. 2	
CIO 2030		Unit No. 3
CIO 2040	Unit No. 4	
CIO 2050		Unit No. 5
CIO 2060	Unit No. 6	
CIO 2070		
:		
CIO 2920	Unit No. 92	
CIO 2930		Unit No. 93
CIO 2940	Unit No. 94	
CIO 2950		

Allocating Four Unit Numbers per Node (Communications Mode 1)

CIO 2000 + (10 × unit No.) to CIO 2039 + (10 × unit No.): Unit No.= 0 to 92

First allocated word	Unit number setting			
CIO 2000	Unit No. 0			
CIO 2010		Unit No. 1		
CIO 2020			Unit No. 2	
CIO 2030				Unit No. 3
CIO 2040	Unit No. 4			
CIO 2050		Unit No. 5		
CIO 2060			Unit No. 6	
CIO 2070				Unit No. 7
CIO 2080				
CIO 2090				
CIO 2100				
:				
CIO 2890	Unit No. 89			
CIO 2900		Unit No. 90		
CIO 2910			Unit No. 91	
CIO 2920				Unit No. 92
CIO 2930				
CIO 2940				
CIO 2950				

Allocating Eight Unit Numbers per Node (Communications Modes 2 and 3)

CIO 2000 + (10 × unit No.) to CIO 2079 + (10 × unit No.): Unit No.= 0 to 88

First allocated word	Unit number setting							
CIO 2000	Unit No. 0	Unit No. 1	Unit No. 2	Unit No. 3	Unit No. 4	Unit No. 5	Unit No. 6	Unit No. 7
CIO 2010								
CIO 2020								
CIO 2030								
CIO 2040								
CIO 2050								
CIO 2060								
CIO 2070								
CIO 2080	Unit No. 8	Unit No. 9	Unit No. 10	Unit No. 11	Unit No. 12	Unit No. 13	Unit No. 14	Unit No. 15
CIO 2090								
CIO 2100								
CIO 2110								
CIO 2120								
CIO 2130								
CIO 2140								
CIO 2150								
CIO 2160								
CIO 2170								
CIO 2180								
CIO 2190								
CIO 2200								
CIO 2210								
CIO 2220								
:								
CIO 2810	Unit No. 81	Unit No. 82	Unit No. 83	Unit No. 84	Unit No. 85	Unit No. 86	Unit No. 87	Unit No. 88
CIO 2820								
CIO 2830								
CIO 2840								
CIO 2850								
CIO 2860								
CIO 2870								
CIO 2880								
CIO 2890								
CIO 2900								
CIO 2910								
CIO 2920								
CIO 2930								
CIO 2940								
CIO 2950								

5-2-3 Types of Node Addresses in CompoNet Networks

There are three types of node addresses in a CompoNet Network.

- Word node addresses
- Bit node addresses

• Repeater Unit node addresses

Node address type	Node name		Node address name	Address range	Applicable Slave Units	Label printed on Unit	Color
Word node address	Word Slave Unit	Contact Input Unit	Input	0 to 63	Input Slave Units allocated 16, 8, or 4 inputs per node address	WORD NODE ADR	Orange
		Contact Output Unit	Output	0 to 63	Output Slave Units allocated 16, 8, or 4 outputs per node address	WORD NODE ADR	Yellow
		Contact I/O Unit	I/O	0 to 63	I/O Slave Units allocated 16, 8, or 4 inputs/outputs per node address. The same number is allocated for input and output word node addresses.	WORD NODE ADR	Orange and yellow
Bit node address	Bit Slave Unit	Contact Input Unit	Bit Input	0 to 127	Input Slave Units allocated 2 inputs per node address	BIT NODE ADR	Orange
		Contact Output Unit	Bit Output	0 to 127	Output Slave Units allocated 2 outputs per node address	BIT NODE ADR	Yellow
		Contact I/O Unit	Bit I/O	0 to 127	I/O Slave Units allocated 2 outputs per node address. The same number is allocated for input and output word node addresses.	BIT NODE ADR	Orange and yellow
Repeater Unit node address	Repeater Units		Repeater Unit node	0 to 63	Repeater Units	RPT NODE ADR	Green

The same address cannot be used twice for the same address type.

Example: IN1 cannot be used twice at the same time.

Example: A Contact I/O Unit uses both an IN and an OUT address.

Therefore IN/OUT1, cannot be used at the same time as OUT1 or IN1.

The same address can be used with different address types.

Example: IN1, OUT1, BIT IN1, and BIT OUT1 can be used at the same time.

Note The following table lists the destination addresses for sending messages to Slave Units.

Slave Unit	Allocated address	Destination address for message
I/O Slave Unit	Input and output node addresses	Input node address
Slave Unit with 16 or more points	More than one node address, i.e., the number of addresses used would be the (total number of points ÷ 16) rounded up to the nearest integer.	Node address set on the rotary switch on the front of the Master Unit (the lowest address)
Other Slave Units	Node address set on the rotary switch on the front of the Master Unit	Node address set on the rotary switch on the front of the Master Unit

5-2-4 Details of Slave Unit Allocation in I/O Memory

CompoNet Network I/O data is allocated in CPU Unit I/O memory in units of Word Slave Unit output addresses, Word Slave Unit input addresses, Bit Slave output addresses, and Bit Slave input addresses. Node address areas that are allocated in order of node addresses are reserved for Slave Units of the same type. In a CompoNet Network, each Unit is allocated a node address area of the size required for the Unit based on node address set for the Unit.

Note A single Unit is not limited to one node address area. If a Word Slave Unit has more than 16 points (e.g., 24 points), it is allocated more than one node address area (e.g., two node address areas). A Bit Slave with four points is allocated two node address areas.

Word Slave Unit Data Allocation

Word Slave Units with no more than 16 points are allocated one word (i.e., the node address area for the node address set for the Unit). (See note.)

Note Slave Units with 8 points are also allocated one word. They use the lower byte of the word, and the upper byte remains not used.

Slave Units with more than 16 and no more than 32 points are allocated two words (i.e., the area for the node address set for the Unit plus next node address area). In the same way, below, multiple words are allocated (the set node address area and the following node address areas) to other Slave Units according to their sizes.

Note As long as the same words are not allocated to more than one Unit, the Input Area and Output Area with numerically the same node address can be allocated to Slave Units with different node addresses. (For example, OUT1 can be allocated to the 16 outputs for a Slave Unit set for node address 1, and IN1 can be allocated to the 16 inputs for an Expansion Slave Unit set for node address 0.)

Output Data Allocation

Output Area

Word address	Bit 15	Bit 0
+0		OUT0
+1		OUT1
+2		OUT2
:		:
+62		OUT62
+63		OUT63

Input Data Allocation

Input Area

Word address	Bit 15	Bit 0
+0		IN0
+1		IN1
+2		IN2
:		:
+62		IN62
+63		IN63

Examples:

• 16-Input Slave Unit

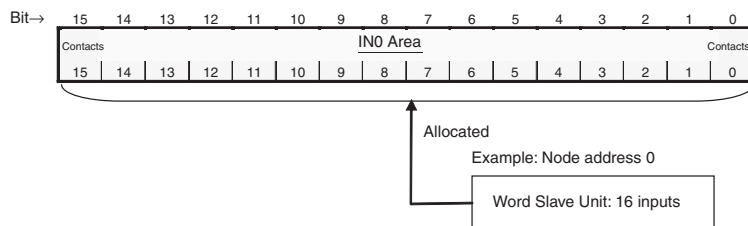

• 16-Output Slave Unit

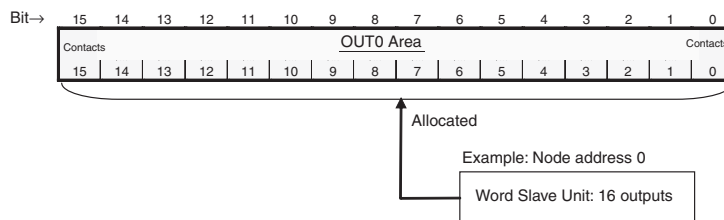

• 24-input Slave Unit

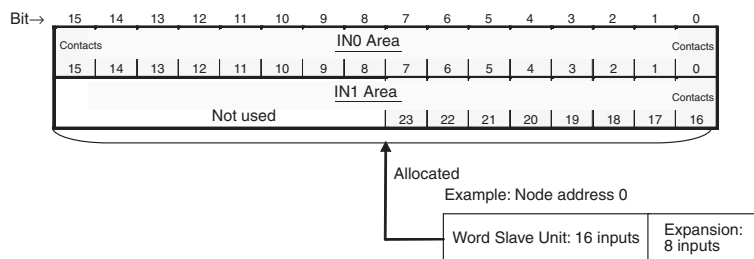

• 24-Output Slave Unit

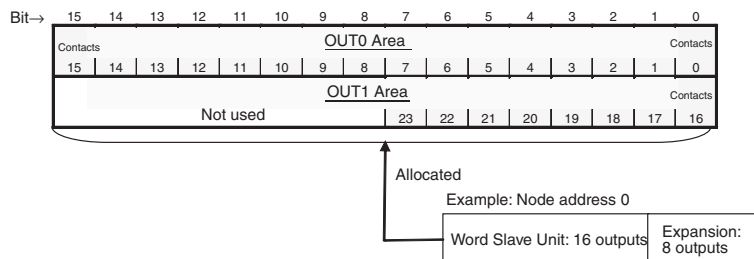

• Slave Unit with Inputs and Outputs

Example: 16 Inputs and 8 Outputs

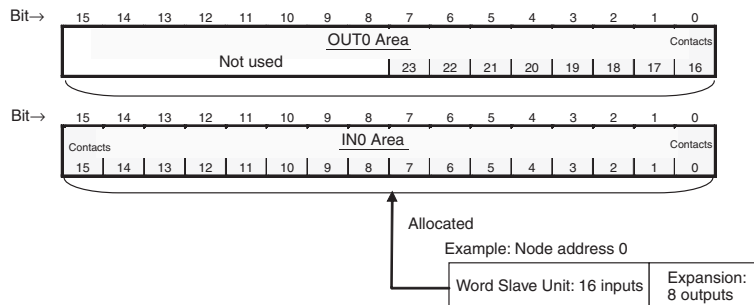

• I/O Example for Word Slave Units

The number of I/O points for Word Slave Units in a CompoNet Network can be increased by using Expansion Units. The following table shows the Slave Unit and Expansion Unit models that can be used.

Basic Unit	Expansion Unit	Inputs	Outputs
CRT1-ID16/ID16-1	None	16	0
	XWT-ID08/ID08-1	24	0
	XWT-OD08/OD08-1	16	8
	XWT-ID16/ID16-1	32	0
	XWT-OD16/OD16-1	16	16
CRT1-OD16/OD16-1	None	0	16
	XWT-ID08/ID08-1	8	16
	XWT-OD08/OD08-1	0	24
	XWT-ID16/ID16-1	16	16
	XWT-OD16/OD16-1	0	32

• I/O Allocation when Expansion Units Are Used

Memory is allocated to a Basic Unit with an Expansion Unit in the same way as it would be allocated to a Slave Unit of the same size as the combination of the sizes of the Basic Unit and Expansion Unit.

The following examples show the allocations when an Expansion Unit is connected to a Basic Unit at node address m (m = 0, 1, 2,...).

16-point Expansion Units

Example 1: Basic Unit (16 Inputs) + Expansion Unit (16 Inputs)

Two node address areas are allocated in the Input Area: m and m+1

Node Address 0: Basic Unit (16 Inputs) + Expansion Unit (16 Inputs)

Input Area	Word address	Bit 15	Bit 0
	+0	IN0	
	+1	IN1	

Example 2: Basic Unit (16 Inputs) + Expansion Unit (16 Outputs)

Two node address areas are allocated: Node address m in the Input Area and node address m in the Output Area.

Node Address 0: Basic Unit (16 Inputs) + Expansion Unit (16 Outputs)

Output Area	Word address	Bit 15	Bit 0
	+0	OUT0	

Input Area	Word address	Bit 15	Bit 0
	+0	IN0	

Example 3: Basic Unit (16 Outputs) + Expansion Unit (16 Inputs)

Two node address areas are allocated: Node address m in the Input Area and node address m in the Output Area.

Node Address 0: Basic Unit (16 Outputs) + Expansion Unit (16 Inputs)

Output Area	Word address	Bit 15	Bit 0
	+0	IN0	

Input Area	Word address	Bit 15	Bit 0
	+0	IN0	

Example 4: Basic Unit (16 Outputs) + Expansion Unit (16 Outputs)

Two node address areas are allocated: Node address m in the Output Area and node address m+1 in the Output Area.

Node Address 0: Basic Unit (16 Outputs) + Expansion Unit (16 Outputs)

Output Area	Word address	Bit 15	Bit 0
	+0	OUT0	
	+1	OUT1	

8-point Expansion Units

Example 1: Basic Unit (16 Inputs) + Expansion Unit (8 Inputs)

Two node address areas are allocated in the Input Area: m and m+1.

Node Address 0: Basic Unit (16 Inputs) + Expansion Unit (8 Inputs)

Input Area	Word address	Bit 15	Bit 0
	+0	IN0	
	+1	IN1	

Example 2: Basic Unit (16 Inputs) + Expansion Unit (8 Outputs)

Two node address areas are allocated: Node address m in the Input Area and node address m in the Output Area.

Node Address 0: Basic Unit (16 Inputs) + Expansion Unit (8 Outputs)

Output Area	Word address	Bit 15	Bit 8	Bit 7	Bit 0
	+0			OUT0	

Input Area	Word address	Bit 15	Bit 0
	+0	IN0	

Example 3: Basic Unit (16 Outputs) + Expansion Unit (8 Inputs)

Two node address areas are allocated: Node address m in the Input Area and node address m in the Output Area.

Node Address 0: Basic Unit (16 Outputs) + Expansion Unit (8 Inputs)

Output Area	Word address	Bit 15	Bit 0
	+0	OUT0	

Input Area	Word address	Bit 15	Bit 8	Bit 7	Bit 0
	+0			IN0	

Example 4: Basic Unit (16 Outputs) + Expansion Unit (8 Outputs)

Two node address areas are allocated: Node address m in the Output Area and node address m+1 in the Output Area.

Node Address 0: Basic Unit (16 Outputs) + Expansion Unit (8 Outputs)

Output Area	Word address	Bit 15	Bit 8	Bit 7	Bit 0
	+0	OUT0			
	+1			OUT1	

- Note** (1) For Slave Units with both inputs and outputs (see note (2)), the Input Area node address is used as the Slave Unit node address. Therefore, the Participation Flag and Communications Error Flag correspond to node address bits for the Input Area.

- (2) A Basic Unit and Expansion Unit combined to provide both inputs and outputs, or a CRT1B-MD Bit Slave, which provides both inputs and outputs.

Bit Slave Unit Data Allocation

Bit Slave Units are allocated two bits for each two points. For example, eight Slave Units with two points each would be allocated one word. Likewise, four Slave Units with two points each and two Slave Units with four points each would be allocated one word.

A Slave Unit with two points is allocated two bits in the node address area for the node address set for the Unit.

A Slave Unit with four points is allocated four bits, two bits in the node address area for the node address set for the Unit and two bits in the next node address area.

Note As long as the same memory is not used by more than one Unit, the Bit Input Area and the Bit Output Area with the same numeric bit node address can be allocated to Bit Slave Units with different node addresses. (For example, two output bits for a 2-point Slave Unit set for node address 1 can be allocated BIT OUT1, and the last two input bits for a 4-input Slave Unit set for node address 0 can be allocated BIT IN1.)

Bit Input Data Allocations

Bits	15	14	13	12	11	10	9	8	7	6	5	4	3	2	1	0
Word address +0	BIT IN7		BIT IN6		BIT IN5		BIT IN4		BIT IN3		BIT IN2		BIT IN1		BIT IN0	
+1	BIT IN15		BIT IN14		BIT IN13		BIT IN12		BIT IN11		BIT IN10		BIT IN9		BIT IN8	
+2	BIT IN23		BIT IN22		BIT IN21		BIT IN20		BIT IN19		BIT IN18		BIT IN17		BIT IN16	
+3	BIT IN31		BIT IN30		BIT IN29		BIT IN28		BIT IN27		BIT IN26		BIT IN25		BIT IN24	
+4	BIT IN39		BIT IN38		BIT IN37		BIT IN36		BIT IN35		BIT IN34		BIT IN33		BIT IN32	
+5	BIT IN47		BIT IN46		BIT IN45		BIT IN44		BIT IN43		BIT IN42		BIT IN41		BIT IN40	
+6	BIT IN55		BIT IN54		BIT IN53		BIT IN52		BIT IN51		BIT IN50		BIT IN49		BIT IN48	
+7	BIT IN63		BIT IN62		BIT IN61		BIT IN60		BIT IN59		BIT IN58		BIT IN57		BIT IN56	
+8	BIT IN71		BIT IN70		BIT IN69		BIT IN68		BIT IN67		BIT IN66		BIT IN65		BIT IN64	
+9	BIT IN79		BIT IN78		BIT IN77		BIT IN76		BIT IN75		BIT IN74		BIT IN73		BIT IN72	
+10	BIT IN87		BIT IN86		BIT IN85		BIT IN84		BIT IN83		BIT IN82		BIT IN81		BIT IN80	
+11	BIT IN95		BIT IN94		BIT IN93		BIT IN92		BIT IN91		BIT IN90		BIT IN89		BIT IN88	
+12	BIT IN103		BIT IN102		BIT IN101		BIT IN100		BIT IN99		BIT IN98		BIT IN97		BIT IN96	
+13	BIT IN111		BIT IN110		BIT IN109		BIT IN108		BIT IN107		BIT IN106		BIT IN105		BIT IN104	
+14	BIT IN119		BIT IN118		BIT IN117		BIT IN116		BIT IN115		BIT IN114		BIT IN113		BIT IN112	
+15	BIT IN127		BIT IN126		BIT IN125		BIT IN124		BIT IN123		BIT IN122		BIT IN121		BIT IN120	

Bit Output Data Allocations

Word address	15	14	13	12	11	10	9	8	7	6	5	4	3	2	1	0
+0	BIT OUT7	BIT OUT6	BIT OUT5	BIT OUT4	BIT OUT3	BIT OUT2	BIT OUT1	BIT OUT0								
+1	BIT OUT15	BIT OUT14	BIT OUT13	BIT OUT12	BIT OUT11	BIT OUT10	BIT OUT9	BIT OUT8								
+2	BIT OUT23	BIT OUT22	BIT OUT21	BIT OUT20	BIT OUT19	BIT OUT18	BIT OUT17	BIT OUT16								
+3	BIT OUT31	BIT OUT30	BIT OUT29	BIT OUT28	BIT OUT27	BIT OUT26	BIT OUT25	BIT OUT24								
+4	BIT OUT39	BIT OUT38	BIT OUT37	BIT OUT36	BIT OUT35	BIT OUT34	BIT OUT33	BIT OUT32								
+5	BIT OUT47	BIT OUT46	BIT OUT45	BIT OUT44	BIT OUT43	BIT OUT42	BIT OUT41	BIT OUT40								
+6	BIT OUT55	BIT OUT54	BIT OUT53	BIT OUT52	BIT OUT51	BIT OUT50	BIT OUT49	BIT OUT48								
+7	BIT OUT63	BIT OUT62	BIT OUT61	BIT OUT60	BIT OUT59	BIT OUT58	BIT OUT57	BIT OUT56								
+8	BIT OUT71	BIT OUT70	BIT OUT69	BIT OUT68	BIT OUT67	BIT OUT66	BIT OUT65	BIT OUT64								
+9	BIT OUT79	BIT OUT78	BIT OUT77	BIT OUT76	BIT OUT75	BIT OUT74	BIT OUT73	BIT OUT72								
+10	BIT OUT87	BIT OUT86	BIT OUT85	BIT OUT84	BIT OUT83	BIT OUT82	BIT OUT81	BIT OUT80								
+11	BIT OUT95	BIT OUT94	BIT OUT93	BIT OUT92	BIT OUT91	BIT OUT90	BIT OUT89	BIT OUT88								
+12	BIT OUT103	BIT OUT102	BIT OUT101	BIT OUT100	BIT OUT99	BIT OUT98	BIT OUT97	BIT OUT96								
+13	BIT OUT111	BIT OUT110	BIT OUT109	BIT OUT108	BIT OUT107	BIT OUT106	BIT OUT105	BIT OUT104								
+14	BIT OUT119	BIT OUT118	BIT OUT117	BIT OUT116	BIT OUT115	BIT OUT114	BIT OUT113	BIT OUT112								
+15	BIT OUT127	BIT OUT126	BIT OUT125	BIT OUT124	BIT OUT123	BIT OUT122	BIT OUT121	BIT OUT120								

Examples

- Slave Unit with 2 Inputs

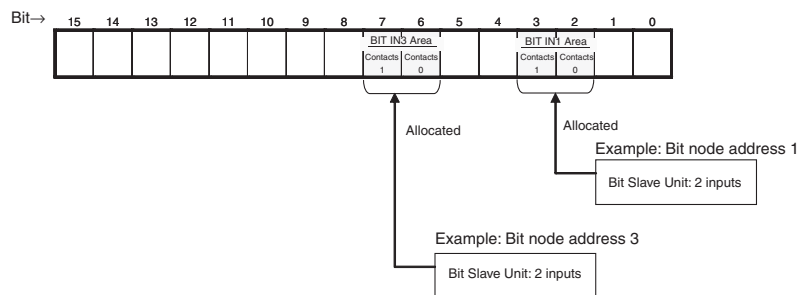

- Slave Unit with 4 Inputs

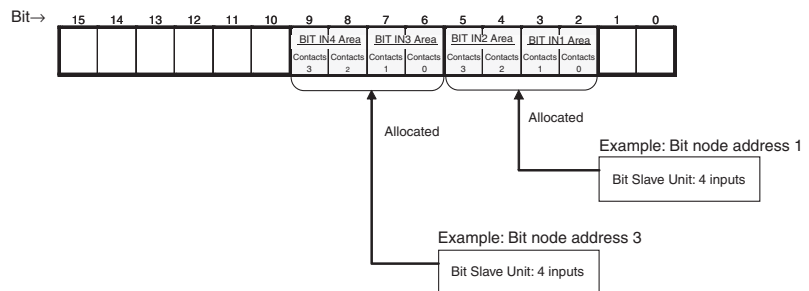

Area Allocations According to Communications Mode Number

Word output data, word input data, bit output data, and bit input data are allocated according to communications mode numbers as shown below.

Communications Modes Other Than Mode 8

The fixed number of node address areas for word output data, word input data, bit output data, and bit input data are allocated in order in the Special I/O Unit Area. The first address that is allocated depends on the unit number of the Master Unit.

Communi- cations mode num- ber	Pattern																																									
0	Special I/O Unit Area CIO 2000 + (10 x unit number)	<table border="1" style="width: 100%; border-collapse: collapse;"> <thead> <tr> <th style="width: 20%;">Word address</th> <th style="width: 60%;">Bit 15</th> <th style="width: 20%;">Bit 0</th> </tr> </thead> <tbody> <tr> <td style="text-align: center;">+0</td> <td colspan="2" style="text-align: center;">[OUT0]</td> </tr> <tr> <td style="text-align: center;">:</td> <td colspan="2" style="text-align: center;">:</td> </tr> <tr> <td style="text-align: center;">+7</td> <td colspan="2" style="text-align: center;">[OUT7]</td> </tr> <tr> <td style="text-align: center;">+8</td> <td colspan="2" style="text-align: center;">[IN0]</td> </tr> <tr> <td style="text-align: center;">:</td> <td colspan="2" style="text-align: center;">:</td> </tr> <tr> <td style="text-align: center;">+15</td> <td colspan="2" style="text-align: center;">[IN7]</td> </tr> <tr> <td style="text-align: center;">+16</td> <td colspan="2" style="text-align: center;">Status</td> </tr> <tr> <td style="text-align: center;">+17</td> <td colspan="2" style="text-align: center;">Parameters</td> </tr> <tr> <td style="text-align: center;">+18</td> <td style="font-size: small;">Communications Error Flags: OUT0 to OUT7</td> <td style="font-size: small;">Participation Flags: OUT0 to OUT7</td> </tr> <tr> <td style="text-align: center;">+19</td> <td style="font-size: small;">Communications Error Flags: IN0 to IN7</td> <td style="font-size: small;">Participation Flags: IN0 to IN7</td> </tr> </tbody> </table>	Word address	Bit 15	Bit 0	+0	[OUT0]		:	:		+7	[OUT7]		+8	[IN0]		:	:		+15	[IN7]		+16	Status		+17	Parameters		+18	Communications Error Flags: OUT0 to OUT7	Participation Flags: OUT0 to OUT7	+19	Communications Error Flags: IN0 to IN7	Participation Flags: IN0 to IN7							
Word address	Bit 15	Bit 0																																								
+0	[OUT0]																																									
:	:																																									
+7	[OUT7]																																									
+8	[IN0]																																									
:	:																																									
+15	[IN7]																																									
+16	Status																																									
+17	Parameters																																									
+18	Communications Error Flags: OUT0 to OUT7	Participation Flags: OUT0 to OUT7																																								
+19	Communications Error Flags: IN0 to IN7	Participation Flags: IN0 to IN7																																								
1	Special I/O Unit Area CIO 2000 + (10 x unit number)	<table border="1" style="width: 100%; border-collapse: collapse;"> <thead> <tr> <th style="width: 20%;">Word address</th> <th style="width: 60%;">Bit 15</th> <th style="width: 20%;">Bit 0</th> </tr> </thead> <tbody> <tr> <td style="text-align: center;">+0</td> <td colspan="2" style="text-align: center;">[OUT0]</td> </tr> <tr> <td style="text-align: center;">:</td> <td colspan="2" style="text-align: center;">:</td> </tr> <tr> <td style="text-align: center;">+15</td> <td colspan="2" style="text-align: center;">[OUT15]</td> </tr> <tr> <td style="text-align: center;">+16</td> <td colspan="2" style="text-align: center;">[IN0]</td> </tr> <tr> <td style="text-align: center;">:</td> <td colspan="2" style="text-align: center;">:</td> </tr> <tr> <td style="text-align: center;">+31</td> <td colspan="2" style="text-align: center;">[IN15]</td> </tr> <tr> <td style="text-align: center;">+32</td> <td colspan="2" style="text-align: center;">Status</td> </tr> <tr> <td style="text-align: center;">+33</td> <td colspan="2" style="text-align: center;">Parameters</td> </tr> <tr> <td style="text-align: center;">+34</td> <td style="font-size: small;">Communications Error Flags: OUT0 to OUT7</td> <td style="font-size: small;">Participation Flags: OUT0 to OUT7</td> </tr> <tr> <td style="text-align: center;">+35</td> <td style="font-size: small;">Communications Error Flags: IN0 to IN7</td> <td style="font-size: small;">Participation Flags: IN0 to IN7</td> </tr> <tr> <td style="text-align: center;">+36</td> <td style="font-size: small;">Communications Error Flags: OUT8 to OUT15</td> <td style="font-size: small;">Participation Flags: OUT8 to OUT15</td> </tr> <tr> <td style="text-align: center;">+37</td> <td style="font-size: small;">Communications Error Flags: IN8 to IN15</td> <td style="font-size: small;">Participation Flags: IN8 to IN15</td> </tr> </tbody> </table>	Word address	Bit 15	Bit 0	+0	[OUT0]		:	:		+15	[OUT15]		+16	[IN0]		:	:		+31	[IN15]		+32	Status		+33	Parameters		+34	Communications Error Flags: OUT0 to OUT7	Participation Flags: OUT0 to OUT7	+35	Communications Error Flags: IN0 to IN7	Participation Flags: IN0 to IN7	+36	Communications Error Flags: OUT8 to OUT15	Participation Flags: OUT8 to OUT15	+37	Communications Error Flags: IN8 to IN15	Participation Flags: IN8 to IN15	
Word address	Bit 15	Bit 0																																								
+0	[OUT0]																																									
:	:																																									
+15	[OUT15]																																									
+16	[IN0]																																									
:	:																																									
+31	[IN15]																																									
+32	Status																																									
+33	Parameters																																									
+34	Communications Error Flags: OUT0 to OUT7	Participation Flags: OUT0 to OUT7																																								
+35	Communications Error Flags: IN0 to IN7	Participation Flags: IN0 to IN7																																								
+36	Communications Error Flags: OUT8 to OUT15	Participation Flags: OUT8 to OUT15																																								
+37	Communications Error Flags: IN8 to IN15	Participation Flags: IN8 to IN15																																								

Communi- cations mode num- ber	Pattern																																																																									
2	Special I/O Unit Area CIO 2000 + (10 x unit number)	<table border="1" style="width: 100%; border-collapse: collapse;"> <thead> <tr> <th style="width: 15%;">Word address</th> <th style="width: 15%;">Bit 15</th> <th style="width: 70%;">Bit 0</th> </tr> </thead> <tbody> <tr><td>+0</td><td></td><td>[OUT0]</td></tr> <tr><td>:</td><td></td><td>:</td></tr> <tr><td>+30</td><td></td><td>[OUT30]</td></tr> <tr><td>+31</td><td></td><td>[OUT31]</td></tr> <tr><td>+32</td><td></td><td>[IN0]</td></tr> <tr><td>:</td><td></td><td>:</td></tr> <tr><td>+62</td><td></td><td>[IN30]</td></tr> <tr><td>+63</td><td></td><td>[IN31]</td></tr> <tr><td>+64</td><td></td><td>Status</td></tr> <tr><td>+65</td><td></td><td>Parameters</td></tr> <tr><td>+66</td><td>Communications Error Flags: OUT0 to OUT7</td><td>Participation Flags: OUT0 to OUT7</td></tr> <tr><td>+67</td><td>Communications Error Flags: IN0 to IN7</td><td>Participation Flags: IN0 to IN7</td></tr> <tr><td>+68</td><td>Communications Error Flags: OUT8 to OUT15</td><td>Participation Flags: OUT8 to OUT15</td></tr> <tr><td>+69</td><td>Communications Error Flags: IN8 to IN15</td><td>Participation Flags: IN8 to IN15</td></tr> <tr><td>+70</td><td>Communications Error Flags: OUT16 to OUT23</td><td>Participation Flags: OUT16 to OUT23</td></tr> <tr><td>+71</td><td>Communications Error Flags: IN16 to IN23</td><td>Participation Flags: IN16 to IN23</td></tr> <tr><td>+72</td><td>Communications Error Flags: OUT24 to OUT31</td><td>Participation Flags: OUT24 to OUT31</td></tr> <tr><td>+73</td><td>Communications Error Flags: IN24 to IN31</td><td>Participation Flags: IN24 to IN31</td></tr> </tbody> </table>	Word address	Bit 15	Bit 0	+0		[OUT0]	:		:	+30		[OUT30]	+31		[OUT31]	+32		[IN0]	:		:	+62		[IN30]	+63		[IN31]	+64		Status	+65		Parameters	+66	Communications Error Flags: OUT0 to OUT7	Participation Flags: OUT0 to OUT7	+67	Communications Error Flags: IN0 to IN7	Participation Flags: IN0 to IN7	+68	Communications Error Flags: OUT8 to OUT15	Participation Flags: OUT8 to OUT15	+69	Communications Error Flags: IN8 to IN15	Participation Flags: IN8 to IN15	+70	Communications Error Flags: OUT16 to OUT23	Participation Flags: OUT16 to OUT23	+71	Communications Error Flags: IN16 to IN23	Participation Flags: IN16 to IN23	+72	Communications Error Flags: OUT24 to OUT31	Participation Flags: OUT24 to OUT31	+73	Communications Error Flags: IN24 to IN31	Participation Flags: IN24 to IN31															
Word address	Bit 15	Bit 0																																																																								
+0		[OUT0]																																																																								
:		:																																																																								
+30		[OUT30]																																																																								
+31		[OUT31]																																																																								
+32		[IN0]																																																																								
:		:																																																																								
+62		[IN30]																																																																								
+63		[IN31]																																																																								
+64		Status																																																																								
+65		Parameters																																																																								
+66	Communications Error Flags: OUT0 to OUT7	Participation Flags: OUT0 to OUT7																																																																								
+67	Communications Error Flags: IN0 to IN7	Participation Flags: IN0 to IN7																																																																								
+68	Communications Error Flags: OUT8 to OUT15	Participation Flags: OUT8 to OUT15																																																																								
+69	Communications Error Flags: IN8 to IN15	Participation Flags: IN8 to IN15																																																																								
+70	Communications Error Flags: OUT16 to OUT23	Participation Flags: OUT16 to OUT23																																																																								
+71	Communications Error Flags: IN16 to IN23	Participation Flags: IN16 to IN23																																																																								
+72	Communications Error Flags: OUT24 to OUT31	Participation Flags: OUT24 to OUT31																																																																								
+73	Communications Error Flags: IN24 to IN31	Participation Flags: IN24 to IN31																																																																								
3	Special I/O Unit Area CIO 2000 + (10 x unit number)	<table border="1" style="width: 100%; border-collapse: collapse;"> <thead> <tr> <th style="width: 15%;">Word address</th> <th style="width: 15%;">Bit 15</th> <th style="width: 70%;">Bit 0</th> </tr> </thead> <tbody> <tr><td>+0</td><td></td><td>[OUT0]</td></tr> <tr><td>:</td><td></td><td>:</td></tr> <tr><td>+15</td><td></td><td>[OUT15]</td></tr> <tr><td>+16</td><td></td><td>[IN0]</td></tr> <tr><td>:</td><td></td><td>:</td></tr> <tr><td>+31</td><td></td><td>[IN15]</td></tr> <tr><td>+32</td><td>[BIT OUT 7]</td><td>[BIT OUT 6] [BIT OUT 5] [BIT OUT 4] [BIT OUT 3] [BIT OUT 2] [BIT OUT 1] [BIT OUT 0]</td></tr> <tr><td>:</td><td>:</td><td>:</td></tr> <tr><td>+39</td><td>[BIT OUT 63] [BIT OUT 62] [BIT OUT 61] [BIT OUT 60] [BIT OUT 59] [BIT OUT 58] [BIT OUT 57] [BIT OUT 56]</td><td></td></tr> <tr><td>+40</td><td>[BIT IN 7] [BIT IN 6] [BIT IN 5] [BIT IN 4] [BIT IN 3] [BIT IN 2] [BIT IN 1] [BIT IN 0]</td><td></td></tr> <tr><td>:</td><td>:</td><td>:</td></tr> <tr><td>+47</td><td>[BIT IN 63] [BIT IN 62] [BIT IN 61] [BIT IN 60] [BIT IN 59] [BIT IN 58] [BIT IN 57] [BIT IN 56]</td><td></td></tr> <tr><td>+48</td><td></td><td>Status</td></tr> <tr><td>+49</td><td></td><td>Parameters</td></tr> <tr><td>+50</td><td>Communications Error Flags: OUT0 to OUT7</td><td>Participation Flags: OUT0 to OUT7</td></tr> <tr><td>+51</td><td>Communications Error Flags: IN0 to IN7</td><td>Participation Flags: IN0 to IN7</td></tr> <tr><td>+52</td><td>Communications Error Flags: OUT8 to OUT15</td><td>Participation Flags: OUT8 to OUT15</td></tr> <tr><td>+53</td><td>Communications Error Flags: IN8 to IN15</td><td>Participation Flags: IN8 to IN15</td></tr> <tr><td>+54</td><td>Communications Error Flags: BIT OUT0 to BIT OUT7</td><td>Participation Flags: BIT OUT0 to BIT OUT7</td></tr> <tr><td>+55</td><td>Communications Error Flags: BIT IN0 to BIT IN7</td><td>Participation Flags: BIT IN0 to BIT IN7</td></tr> <tr><td>:</td><td>:</td><td>:</td></tr> <tr><td>+68</td><td>Communications Error Flags: BIT OUT56 to BIT OUT63</td><td>Participation Flags: BIT OUT56 to BIT OUT63</td></tr> <tr><td>+69</td><td>Communications Error Flags: BIT IN56 to BIT IN63</td><td>Participation Flags: BIT IN56 to BIT IN63</td></tr> </tbody> </table>	Word address	Bit 15	Bit 0	+0		[OUT0]	:		:	+15		[OUT15]	+16		[IN0]	:		:	+31		[IN15]	+32	[BIT OUT 7]	[BIT OUT 6] [BIT OUT 5] [BIT OUT 4] [BIT OUT 3] [BIT OUT 2] [BIT OUT 1] [BIT OUT 0]	:	:	:	+39	[BIT OUT 63] [BIT OUT 62] [BIT OUT 61] [BIT OUT 60] [BIT OUT 59] [BIT OUT 58] [BIT OUT 57] [BIT OUT 56]		+40	[BIT IN 7] [BIT IN 6] [BIT IN 5] [BIT IN 4] [BIT IN 3] [BIT IN 2] [BIT IN 1] [BIT IN 0]		:	:	:	+47	[BIT IN 63] [BIT IN 62] [BIT IN 61] [BIT IN 60] [BIT IN 59] [BIT IN 58] [BIT IN 57] [BIT IN 56]		+48		Status	+49		Parameters	+50	Communications Error Flags: OUT0 to OUT7	Participation Flags: OUT0 to OUT7	+51	Communications Error Flags: IN0 to IN7	Participation Flags: IN0 to IN7	+52	Communications Error Flags: OUT8 to OUT15	Participation Flags: OUT8 to OUT15	+53	Communications Error Flags: IN8 to IN15	Participation Flags: IN8 to IN15	+54	Communications Error Flags: BIT OUT0 to BIT OUT7	Participation Flags: BIT OUT0 to BIT OUT7	+55	Communications Error Flags: BIT IN0 to BIT IN7	Participation Flags: BIT IN0 to BIT IN7	:	:	:	+68	Communications Error Flags: BIT OUT56 to BIT OUT63	Participation Flags: BIT OUT56 to BIT OUT63	+69	Communications Error Flags: BIT IN56 to BIT IN63	Participation Flags: BIT IN56 to BIT IN63
Word address	Bit 15	Bit 0																																																																								
+0		[OUT0]																																																																								
:		:																																																																								
+15		[OUT15]																																																																								
+16		[IN0]																																																																								
:		:																																																																								
+31		[IN15]																																																																								
+32	[BIT OUT 7]	[BIT OUT 6] [BIT OUT 5] [BIT OUT 4] [BIT OUT 3] [BIT OUT 2] [BIT OUT 1] [BIT OUT 0]																																																																								
:	:	:																																																																								
+39	[BIT OUT 63] [BIT OUT 62] [BIT OUT 61] [BIT OUT 60] [BIT OUT 59] [BIT OUT 58] [BIT OUT 57] [BIT OUT 56]																																																																									
+40	[BIT IN 7] [BIT IN 6] [BIT IN 5] [BIT IN 4] [BIT IN 3] [BIT IN 2] [BIT IN 1] [BIT IN 0]																																																																									
:	:	:																																																																								
+47	[BIT IN 63] [BIT IN 62] [BIT IN 61] [BIT IN 60] [BIT IN 59] [BIT IN 58] [BIT IN 57] [BIT IN 56]																																																																									
+48		Status																																																																								
+49		Parameters																																																																								
+50	Communications Error Flags: OUT0 to OUT7	Participation Flags: OUT0 to OUT7																																																																								
+51	Communications Error Flags: IN0 to IN7	Participation Flags: IN0 to IN7																																																																								
+52	Communications Error Flags: OUT8 to OUT15	Participation Flags: OUT8 to OUT15																																																																								
+53	Communications Error Flags: IN8 to IN15	Participation Flags: IN8 to IN15																																																																								
+54	Communications Error Flags: BIT OUT0 to BIT OUT7	Participation Flags: BIT OUT0 to BIT OUT7																																																																								
+55	Communications Error Flags: BIT IN0 to BIT IN7	Participation Flags: BIT IN0 to BIT IN7																																																																								
:	:	:																																																																								
+68	Communications Error Flags: BIT OUT56 to BIT OUT63	Participation Flags: BIT OUT56 to BIT OUT63																																																																								
+69	Communications Error Flags: BIT IN56 to BIT IN63	Participation Flags: BIT IN56 to BIT IN63																																																																								

Communications Mode No. 8: Software Setting

With communications mode 8, the first address and number of node address areas allocated are set on the CompoNet Support Software's Master Unit I/O Allocation Tab Page for word output data, word input data, bit output data, and bit input data.

The first address for each area can be set in any location in the CIO, DM, WR, or HR Area.

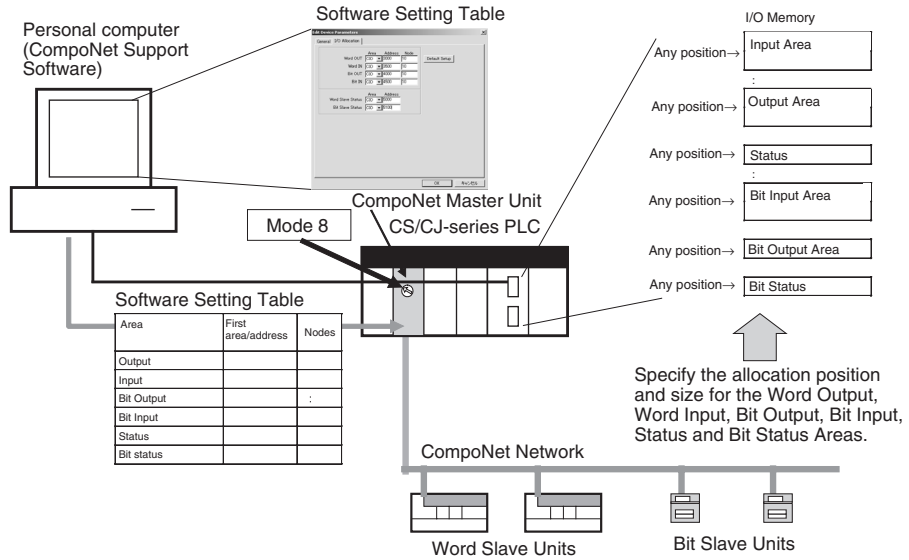

■ Word Slave Output Area (OUT)

The first address is specified.

Word address	Bit 15	Bit 0
+0	[OUT0]	
+1	[OUT1]	
+2	[OUT2]	
:	:	
+N-1	[OUT (N-1)]	
:	Not allocated.	
+63	Not allocated.	

The number of nodes address areas is specified.

■ Word Slave Input Area (IN)

The first address is specified.

Word address	Bit 15	Bit 0
+0	[IN0]	
+1	[IN1]	
+2	[IN2]	
:	:	
+N-1	[IN (N-1)]	
:	Not allocated.	
+63	Not allocated.	

The number of nodes address areas is specified.

■ Bit Slave Output Area (BIT OUT)

The first address is specified.

Word address	Bit															
	15	14	13	12	11	10	9	8	7	6	5	4	3	2	1	0
+0	[BIT IN 7]	[BIT IN 6]	[BIT IN 5]	[BIT IN 4]	[BIT IN 3]	[BIT IN 2]	[BIT IN 1]	[BIT IN 0]								
+1	[BIT IN 15]	[BIT IN 14]	[BIT IN 13]	[BIT IN 12]	[BIT IN 11]	[BIT IN 10]	[BIT IN 9]	[BIT IN 8]								
+2	[BIT IN 23]	[BIT IN 22]	[BIT IN 21]	[BIT IN 20]	[BIT IN 19]	[BIT IN 18]	[BIT IN 17]	[BIT IN 16]								
+3	[BIT IN 31]	[BIT IN 30]	[BIT IN 29]	[BIT IN 28]	[BIT IN 27]	[BIT IN 26]	[BIT IN 25]	[BIT IN 24]								
+4	[BIT IN 39]	[BIT IN 38]	[BIT IN 37]	[BIT IN 36]	[BIT IN 35]	[BIT IN 34]	[BIT IN 33]	[BIT IN 32]								
+5	[BIT IN 47]	[BIT IN 46]	[BIT IN 45]	[BIT IN 44]	[BIT IN 43]	[BIT IN 42]	[BIT IN 41]	[BIT IN 40]								
+6	[BIT IN 55]	[BIT IN 54]	[BIT IN 53]	[BIT IN 52]	[BIT IN 51]	[BIT IN 50]	[BIT IN 49]	[BIT IN 48]								
+7	[BIT IN 63]	[BIT IN 62]	[BIT IN 61]	[BIT IN 60]	[BIT IN 59]	[BIT IN 58]	[BIT IN 57]	[BIT IN 56]								
+8	[BIT IN 71]	[BIT IN 70]	[BIT IN 69]	[BIT IN 68]	[BIT IN 67]	[BIT IN 66]	[BIT IN 65]	[BIT IN 64]								
+9	[BIT IN 79]	[BIT IN 78]	[BIT IN 77]	[BIT IN 76]	[BIT IN 75]	[BIT IN 74]	[BIT IN 73]	[BIT IN 72]								
+10	Not allocated.	Not allocated.	Not allocated.	Not allocated.	Not allocated.	Not allocated.	[BIT IN 81]	[BIT IN 80]								
+11	Not allocated.	Not allocated.	Not allocated.	Not allocated.	Not allocated.	Not allocated.	Not allocated.	Not allocated.								
+12	Not allocated.	Not allocated.	Not allocated.	Not allocated.	Not allocated.	Not allocated.	Not allocated.	Not allocated.								
+13	Not allocated.	Not allocated.	Not allocated.	Not allocated.	Not allocated.	Not allocated.	Not allocated.	Not allocated.								
+14	Not allocated.	Not allocated.	Not allocated.	Not allocated.	Not allocated.	Not allocated.	Not allocated.	Not allocated.								
+15	Not allocated.	Not allocated.	Not allocated.	Not allocated.	Not allocated.	Not allocated.	Not allocated.	Not allocated.								

Example: When 82 is specified as the number of nodes N

■ Bit Slave Input Area (BIT IN)

Word address	15	14	13	12	11	10	9	8	7	6	5	4	3	2	1	0
+0	[BIT OUT 7]	[BIT OUT 6]	[BIT OUT 5]	[BIT OUT 4]	[BIT OUT 3]	[BIT OUT 2]	[BIT OUT 1]	[BIT OUT 0]								
+1	[BIT OUT 15]	[BIT OUT 14]	[BIT OUT 13]	[BIT OUT 12]	[BIT OUT 11]	[BIT OUT 10]	[BIT OUT 9]	[BIT OUT 8]								
+2	[BIT OUT 23]	[BIT OUT 22]	[BIT OUT 21]	[BIT OUT 20]	[BIT OUT 19]	[BIT OUT 18]	[BIT OUT 17]	[BIT OUT 16]								
+3	[BIT OUT 31]	[BIT OUT 30]	[BIT OUT 29]	[BIT OUT 28]	[BIT OUT 27]	[BIT OUT 26]	[BIT OUT 25]	[BIT OUT 24]								
+4	[BIT OUT 39]	[BIT OUT 38]	[BIT OUT 37]	[BIT OUT 36]	[BIT OUT 35]	[BIT OUT 34]	[BIT OUT 33]	[BIT OUT 32]								
+5	[BIT OUT 47]	[BIT OUT 46]	[BIT OUT 45]	[BIT OUT 44]	[BIT OUT 43]	[BIT OUT 42]	[BIT OUT 41]	[BIT OUT 40]								
+6	[BIT OUT 55]	[BIT OUT 54]	[BIT OUT 53]	[BIT OUT 52]	[BIT OUT 51]	[BIT OUT 50]	[BIT OUT 49]	[BIT OUT 48]								
+7	[BIT OUT 63]	[BIT OUT 62]	[BIT OUT 61]	[BIT OUT 60]	[BIT OUT 59]	[BIT OUT 58]	[BIT OUT 57]	[BIT OUT 56]								
+8	[BIT OUT 71]	[BIT OUT 70]	[BIT OUT 69]	[BIT OUT 68]	[BIT OUT 67]	[BIT OUT 66]	[BIT OUT 65]	[BIT OUT 64]								
+9	[BIT OUT 79]	[BIT OUT 78]	[BIT OUT 77]	[BIT OUT 76]	[BIT OUT 75]	[BIT OUT 74]	[BIT OUT 73]	[BIT OUT 72]								
+10	Not allocated.	Not allocated.	Not allocated.	Not allocated.	Not allocated.	Not allocated.	Not allocated.	[BIT OUT 80]								
+11	Not allocated.	Not allocated.	Not allocated.	Not allocated.	Not allocated.	Not allocated.	Not allocated.	Not allocated.	Not allocated.	Not allocated.	Not allocated.	Not allocated.	Not allocated.	Not allocated.	Not allocated.	Not allocated.
+12	Not allocated.	Not allocated.	Not allocated.	Not allocated.	Not allocated.	Not allocated.	Not allocated.	Not allocated.	Not allocated.	Not allocated.	Not allocated.	Not allocated.	Not allocated.	Not allocated.	Not allocated.	Not allocated.
+13	Not allocated.	Not allocated.	Not allocated.	Not allocated.	Not allocated.	Not allocated.	Not allocated.	Not allocated.	Not allocated.	Not allocated.	Not allocated.	Not allocated.	Not allocated.	Not allocated.	Not allocated.	Not allocated.
+14	Not allocated.	Not allocated.	Not allocated.	Not allocated.	Not allocated.	Not allocated.	Not allocated.	Not allocated.	Not allocated.	Not allocated.	Not allocated.	Not allocated.	Not allocated.	Not allocated.	Not allocated.	Not allocated.
+15	Not allocated.	Not allocated.	Not allocated.	Not allocated.	Not allocated.	Not allocated.	Not allocated.	Not allocated.	Not allocated.	Not allocated.	Not allocated.	Not allocated.	Not allocated.	Not allocated.	Not allocated.	Not allocated.

The first address is specified.

Example: When 82 is specified as the number of nodes N

■ Status, Parameters, Word Slave Participation Flags, and Communications Error Flags (Status)

Word address	Bit 15	Bit 0
+0	Status	
+1	Parameter settings	
+2	Communications Error Flags: OUT0 to OUT7	Participation Flags: OUT0 to OUT7
+3	Communications Error Flags: IN0 to IN7	Participation Flags: IN0 to IN7
:	:	:
+14	Communications Error Flags: OUT56 to OUT63	Participation Flags: OUT56 to OUT63
+15	Communications Error Flags: IN56 to IN63	Participation Flags: IN56 to IN63

The first address is specified.

The number of nodes N is specified.

■ Bit Slave Participation Flags and Communications Error Flags (Bit Status)

Word address	Bit 15	Bit 0
+0	Communications Error Flags: BIT OUT0 to BIT OUT7	Participation Flags: BIT OUT0 to BIT OUT7
+1	Communications Error Flags: BIT IN0 to BIT IN7	Participation Flags: BIT IN0 to BIT IN7
:	:	:
+30	Communications Error Flags: BIT OUT 120 to BIT OUT 127	Participation Flags: BIT OUT 120 to BIT OUT 127
+31	Communications Error Flags: BIT IN 120 to BIT IN 127	Participation Flags: BIT IN 120 to BIT IN 127

The first address is specified.

The number of nodes N is specified.

5-2-5 Status Area Allocation

The Status Area consists of the following three items.

- Status: The status of the network and of the Master Unit
- Parameters: Remote I/O Communications Startup Switches
- Participation Flags and Communications Error Flags: Participation and error flags for applicable Slave Units.

Status

The status of the Master Unit and the entire network are stored here.

Word	Bits															
	15	14	13	12	11	10	09	08	07	06	05	04	03	02	01	00
+m (See note.)	Status															

Note The value of +m depends on the communications mode as follows: The value is +16 for communications mode 0, +32 for mode 1, +64 for mode 2, and +48 for mode 3. For communications mode 8, this value is +0 when the first

address set under *Status* on the Master I/O Allocation Tab Page from Compo-Net Software Support is +0.

Bit address	Name	Contents
00	Communications Error Flag	OFF: Normal ON: Error Turns ON when a communications error occurs at even one applicable Slave Unit. (See note.) Note This applies to all Slave Units if SW4 (REGS) on the Master Unit is turned OFF when the power is turned ON. If SW4 is turned ON when the power is turned ON, then this applies to registered Slave Units only.
01	Registration Table Verification Error Flag	Enabled only in Registration Table Enable Mode, i.e., when SW4 (REGS) is turned ON on the Master Unit when the power is turned ON. OFF: Normal ON: Verification error Turns ON if the actual Slave Unit node addresses and corresponding Slave Unit models do not agree with the information in the Registration Table when the power is turned ON. Note Remote I/O communications will start even if this flag is ON.
02	Communications Error Communications Stop Flag	OFF: Normal, or SW3 (ESTP) on the Master Unit is turned OFF (Communications Error Communications Stop Mode disabled). ON: Error. SW3 (ESTP) on the Master Unit is turned ON (Communications Error Communications Stop Mode enabled) and remote I/O communications were stopped because of a communications error. Once this flag turns ON, it remains ON until the power is cycled or the Unit is restarted.
03	Slave Unit Duplicated Address Error Flag	OFF: Normal ON: Error (The same node address is set for more than one Slave Unit, the same node address area is being used by more than one Slave Unit, or a different type of Slave Unit is participating at the same address after the original Slave Unit left the network.) Note Remote I/O communications will start even if this flag is ON.
04	Repeater Unit Communications Error Flag	OFF: Normal ON: Error Note Remote I/O communications will start even if this flag is ON.
05	Repeater Unit Node Duplicated Address Error Flag	OFF: Normal ON: Error Note Remote I/O communications will start even if this flag is ON.

Bit address	Name	Contents
06	All Registered Slave Units Participating Flag	<p>Enabled only in Registration Table Enable Mode, i.e., when SW4 (REGS) is turned ON on the Master Unit when the power is turned ON.</p> <p>OFF: A Slave Unit is not participating. (Not all Slave Units in the Registration Table are participating.)</p> <p>ON: All Slave Units in the Registration Table are participating.</p> <p>Note Turns ON when all Slave Units in the Registration Table are participating, even if an unregistered Slave Unit is also participating.</p> <p>Note When the Registered Slave Unit Participation Standby Mode is enabled, remote I/O communications will stop while this flag is OFF. They start when it turns ON.</p>
07	Remote I/O Communications Started Flag	<p>OFF: Remote I/O communications are stopped.</p> <p>ON: Remote I/O communications are operating.</p>
08	Ladder Operation Allowed Flag in Registration Table Enabled Mode	<p>OFF: Ladder program operations are not possible. (The ladder program should not be used in relation to remote I/O communications.)</p> <p>ON: Ladder program operations are possible. (The ladder program can be used in relation to remote I/O communications.)</p> <p>Note Flag status is determined by a logical AND based on bit 0 (no communications error), bit 6 (all registered Slave Units participating), and bit 7 (remote I/O communications operating).</p>
09	Reserved	Cannot be used.
10	Registration Table Mode Flag	<p>OFF: Registration Table Disable Mode. SW4 (REGS) on the Master Unit was turned OFF when the power was turned ON, or the Registration Table data is illegal.</p> <p>ON: Registration Table Enable Mode. SW4 (REGS) on the Master Unit was turned ON when the power was turned ON, and the Registration Table data is not illegal.</p>
11	Reserved	Cannot be used.
12	Representative Warning Status Flag	Logical OR of the Warning Status Flags for all Slave Units.
13	Representative Alarm Status Flag	Logical OR of the Alarm Status Flags for all Slave Units.
14	Reserved	Cannot be used.
15	Reserved	Cannot be used.

Note Bits 0, 1, and 3 output a logical OR of the status of all Slave Units other than Repeater Units; bits 4 and 5 output an OR of Repeater Unit status only; and bit 2 outputs an OR of the status of all Slave Units including Repeater Units.

Example: In this example, operation is considered normal when all registered Slave Units are participating, there are no communications errors at any registered Slave Units, and remote I/O communications are operating.

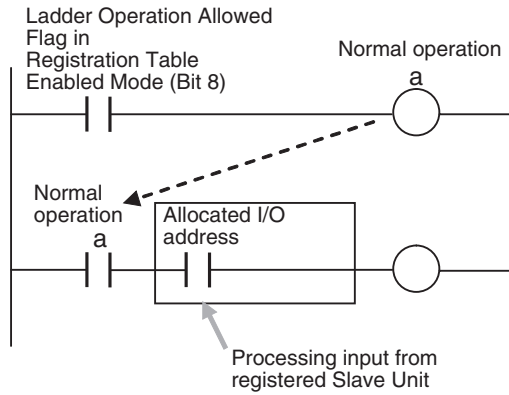

Parameters

Word	Bits															
	15	14	13	12	11	10	09	08	07	06	05	04	03	02	01	00
+n (See note.)	Parameters															

Note The value of +n depends on the communications mode as follows: The value is +17 for communications mode number 0, +33 for mode 1, +65 for mode 2, and +49 for mode 3. For communications mode 8, this value is +1 when the first address set under *Status* on the Master I/O Allocation Tab Page from CompoNet Software Support is +0.

Bit address	Name	Contents
00	Remote I/O Communications Start Switch	<p>OFF: No processing</p> <p>ON: Starts remote I/O communications when turned from OFF to ON. This switch is automatically turned OFF by the system after the system detects that the switch has turned ON.</p> <p>Note 1. Enabled only in Remote I/O Communications Manual Start Mode. I/O Communications Manual Startup Mode is set using the CompoNet Support Software.</p> <p>Note 2. If the Remote I/O Communications Manual Start Mode is disabled or if remote I/O communications have already started, the command to start I/O communications is ignored even if the system detects that the switch has turned ON.</p>
01	Cannot be used.	---
02 to 15	Not used.	0

Participation Flags and Communications Error Flags

These flags indicate nodes participating in the network and nodes where errors have occurred after participation has started.

In Registration Table Enable Mode, only registered Slave Units can participate. (Other Slave Units cannot participate.)

Flag name	Contents
Participation Flag	<p>ON: The applicable Slave Unit has participated in the network. (See note 3.)</p> <p>OFF: Power has been interrupted or a restart has been executed.</p> <p>Note After the system has started, this flag turns ON once the applicable Slave Unit has participated in the network. (It stays ON even if the Slave Unit stops participating because of a communications error.) (See note 3.)</p>
Communications Error Flag	<p>ON: A communications error occurred at the applicable Slave Unit participating in the network. (See note 3.)</p> <p>OFF: A communications error has not occurred at the applicable Slave Unit participating in the network. (See note 3.)</p> <p>Note 1: A Communications Error Flag turns ON if the applicable Slave Unit cannot communicate with the Master Unit for any reason after the Slave Unit has joined the network (i.e., if the Participation Flag is ON). It turns OFF when the error is removed.</p> <p>Note 2: In Communications Error Communications Stop Mode, (i.e., when ESTP is turned ON on the DIP switch on the front of the Master Unit), all remote I/O communications will stop if a communications error occurs at any applicable Slave Units. (See note 3.)</p>

Note 3: When SW4 (REGS) on the front of the Master Unit is turned OFF (registered Slave Unit function disabled), this applies to all Slave Units. When SW4 is turned ON (registered Slave Unit function enabled), it applies only to registered Slave Units.

Bits are allocated for each Slave Unit node address. The leftmost 8 bits are allocated for Communications Error Flags, and the rightmost 8 bits are allocated for Participation Flags.

With Contact I/O Units, only Input Flags for input nodes are allocated. The portion of memory that can be used for Slave Units is allocated in I/O memory at the CPU Unit. (For example, in communications mode 0, there are eight nodes each for inputs and outputs, so words +0 and +1 are used.)

Communications Mode 0

Word (See note.)	Bits															
	15	14	13	12	11	10	09	08	07	06	05	04	03	02	01	00
+18	Output Slave Unit Communications Error Flags (0 to 7)								Output Slave Unit Participation Flags (0 to 7)							
+19	Input Slave Unit Communications Error Flags (0 to 7)								Input Slave Unit Participation Flags (0 to 7)							

Note Word +0 is assumed to be the first word of the memory allocated to Special I/O Units, i.e., CIO 2000 + (10 × unit number).

Communications Mode 1

Word (See note.)	Bits															
	15	14	13	12	11	10	09	08	07	06	05	04	03	02	01	00
+34	Output Slave Unit Communications Error Flags (0 to 7)								Output Slave Unit Participation Flags (0 to 7)							
+35	Input Slave Unit Communications Error Flags (0 to 7)								Input Slave Unit Participation Flags (0 to 7)							

Word (See note.)	Bits															
	15	14	13	12	11	10	09	08	07	06	05	04	03	02	01	00
+36	Output Slave Unit Communications Error Flags (8 to 15)								Output Slave Unit Participation Flags (8 to 15)							
+37	Input Slave Unit Communications Error Flags (8 to 15)								Input Slave Unit Participation Flags (8 to 15)							

Note Word +0 is assumed to be the first word of the memory allocated for Special I/O Units, i.e., CIO 2000 + (10 × unit number).

Communications Mode 2

Word (See note.)	Bits															
	15	14	13	12	11	10	09	08	07	06	05	04	03	02	01	00
+66	Output Slave Unit Communications Error Flags (0 to 7)								Output Slave Unit Participation Flags (0 to 7)							
+67	Input Slave Unit Communications Error Flags (0 to 7)								Input Slave Unit Participation Flags (0 to 7)							
+68	Output Slave Unit Communications Error Flags (8 to 15)								Output Slave Unit Participation Flags (8 to 15)							
+69	Input Slave Unit Communications Error Flags (8 to 15)								Input Slave Unit Participation Flags (8 to 15)							
+70	Output Slave Unit Communications Error Flags (16 to 23)								Output Slave Unit Participation Flags (16 to 23)							
+71	Input Slave Unit Communications Error Flags (16 to 23)								Input Slave Unit Participation Flags (16 to 23)							
+72	Output Slave Unit Communications Error Flags (24 to 31)								Output Slave Unit Participation Flags (24 to 31)							
+73	Input Slave Unit Communications Error Flags (24 to 31)								Input Slave Unit Participation Flags (24 to 31)							

Note Word +0 is assumed to be the first word of the memory allocated for Special I/O Units, i.e., CIO 2000 + (10 × unit number).

Communications Mode 3

Word (See note.)	Bits															
	15	14	13	12	11	10	09	08	07	06	05	04	03	02	01	00
+50	Word Output Slave Unit Communications Error Flags (0 to 7)								Word Output Slave Unit Participation Flags (0 to 7)							
+51	Word Input Slave Unit Communications Error Flags (0 to 7)								Word Input Slave Unit Participation Flags (0 to 7)							
+52	Word Output Slave Unit Communications Error Flags (8 to 15)								Word Output Slave Unit Participation Flags (8 to 15)							
+53	Word Input Slave Unit Communications Error Flags (8 to 15)								Word Input Slave Unit Participation Flags (8 to 15)							
+54	Bit Output Slave Unit Communications Error Flags (0 to 7)								Bit Output Slave Unit Participation Flags (0 to 7)							
+55	Bit Input Slave Unit Communications Error Flags (0 to 7)								Bit Input Slave Unit Participation Flags (0 to 7)							
+56	Bit Output Slave Unit Communications Error Flags (8 to 15)								Bit Output Slave Unit Participation Flags (8 to 15)							
+57	Bit Input Slave Unit Communications Error Flags (8 to 15)								Bit Input Slave Unit Participation Flags (8 to 15)							
+58	Bit Output Slave Unit Communications Error Flags (16 to 23)								Bit Output Slave Unit Participation Flags (16 to 23)							

Word (See note.)	Bits															
	15	14	13	12	11	10	09	08	07	06	05	04	03	02	01	00
+59	Bit Input Slave Unit Communica- tions Error Flags (16 to 23)								Bit Input Slave Unit Participation Flags (16 to 23)							
+60	Bit Output Slave Unit Communica- tions Error Flags (24 to 31)								Bit Output Slave Unit Participation Flags (24 to 31)							
+61	Bit Input Slave Unit Communica- tions Error Flags (24 to 31)								Bit Input Slave Unit Participation Flags (24 to 31)							
+62	Bit Output Slave Unit Communica- tions Error Flags (32 to 39)								Bit Output Slave Unit Participation Flags (32 to 39)							
+63	Bit Input Slave Unit Communica- tions Error Flags (32 to 39)								Bit Input Slave Unit Participation Flags (32 to 39)							
+64	Bit Output Slave Unit Communica- tions Error Flags (40 to 47)								Bit Output Slave Unit Participation Flags (40 to 47)							
+65	Bit Input Slave Unit Communica- tions Error Flags (40 to 47)								Bit Input Slave Unit Participation Flags (40 to 47)							
+66	Bit Output Slave Unit Communica- tions Error Flags (48 to 55)								Bit Output Slave Unit Participation Flags (48 to 55)							
+67	Bit Input Slave Unit Communica- tions Error Flags (48 to 55)								Bit Input Slave Unit Participation Flags (48 to 55)							
+68	Bit Output Slave Unit Communica- tions Error Flags (56 to 63)								Bit Output Slave Unit Participation Flags (56 to 63)							
+69	Bit Input Slave Unit Communica- tions Error Flags (56 to 63)								Bit Input Slave Unit Participation Flags (56 to 63)							

Note Word +0 is assumed to be the first word of the memory allocated for Special I/O Units, i.e., CIO 2000 + (10 × unit number).

Communications Mode 8

■ Word Slave Participation Flags and Communications Error Flags

Word (See note.)	Bit															
	15	14	13	12	11	10	09	08	07	06	05	04	03	02	01	00
+2	Word Output Slave Unit Communications Error Flags (0 to 7)								Word Output Slave Unit Participation Flags (0 to 7)							
+3	Word Input Slave Unit Communications Error Flags (0 to 7)								Word Input Slave Unit Participation Flags (0 to 7)							
+4	Word Output Slave Unit Communications Error Flags (8 to 15)								Word Output Slave Unit Participation Flags (8 to 15)							
+5	Word Input Slave Unit Communications Error Flags (8 to 15)								Word Input Slave Unit Participation Flags (8 to 15)							
+6	Word Output Slave Unit Communications Error Flags (16 to 23)								Word Output Slave Unit Participation Flags (16 to 23)							
+7	Word Input Slave Unit Communications Error Flags (16 to 23)								Word Input Slave Unit Participation Flags (16 to 23)							
+8	Word Output Slave Unit Communications Error Flags (24 to 31)								Word Output Slave Unit Participation Flags (24 to 31)							
+9	Word Input Slave Unit Communications Error Flags (24 to 31)								Word Input Slave Unit Participation Flags (24 to 31)							
+10	Word Output Slave Unit Communications Error Flags (32 to 39)								Word Output Slave Unit Participation Flags (32 to 39)							
+11	Word Input Slave Unit Communications Error Flags (32 to 39)								Word Input Slave Unit Participation Flags (32 to 39)							
+12	Word Output Slave Unit Communications Error Flags (40 to 47)								Word Output Slave Unit Participation Flags (40 to 47)							
+13	Word Input Slave Unit Communications Error Flags (40 to 47)								Word Input Slave Unit Participation Flags (40 to 47)							
+14	Word Output Slave Unit Communications Error Flags (48 to 55)								Word Output Slave Unit Participation Flags (48 to 55)							
+15	Word Input Slave Unit Communications Error Flags (48 to 55)								Word Input Slave Unit Participation Flags (48 to 55)							
+16	Word Output Slave Unit Communications Error Flags (56 to 63)								Word Output Slave Unit Participation Flags (56 to 63)							
+17	Word Input Slave Unit Communications Error Flags (56 to 63)								Word Input Slave Unit Participation Flags (56 to 63)							

Note Word +0 is assumed to be the first address set under Status on the Master I/O Allocation Tab Page in the software setting by the CompoNet Support Software.

■ Bit Slave Participation Flags and Communications Error Flags

Word (See note.)	Bit															
	15	14	13	12	11	10	09	08	07	06	05	04	03	02	01	00
+0	Bit Output Slave Unit Communications Error Flags (0 to 7)								Bit Output Slave Unit Participation Flags (0 to 7)							
+1	Bit Input Slave Unit Communications Error Flags (0 to 7)								Bit Input Slave Unit Participation Flags (0 to 7)							
+2	Bit Output Slave Unit Communications Error Flags (8 to 15)								Bit Output Slave Unit Participation Flags (8 to 15)							
+3	Bit Input Slave Unit Communications Error Flags (8 to 15)								Bit Input Slave Unit Participation Flags (8 to 15)							
+4	Bit Output Slave Unit Communications Error Flags (16 to 23)								Bit Output Slave Unit Participation Flags (16 to 23)							
+5	Bit Input Slave Unit Communications Error Flags (16 to 23)								Bit Input Slave Unit Participation Flags (16 to 23)							
+6	Bit Output Slave Unit Communications Error Flags (24 to 31)								Bit Output Slave Unit Participation Flags (24 to 31)							
+7	Bit Input Slave Unit Communications Error Flags (24 to 31)								Bit Input Slave Unit Participation Flags (24 to 31)							
+8	Bit Output Slave Unit Communications Error Flags (32 to 39)								Bit Output Slave Unit Participation Flags (32 to 39)							
+9	Bit Input Slave Unit Communications Error Flags (32 to 39)								Bit Input Slave Unit Participation Flags (32 to 39)							
+10	Bit Output Slave Unit Communications Error Flags (40 to 47)								Bit Output Slave Unit Participation Flags (40 to 47)							
+11	Bit Input Slave Unit Communications Error Flags (40 to 47)								Bit Input Slave Unit Participation Flags (40 to 47)							
+12	Bit Output Slave Unit Communications Error Flags (48 to 55)								Bit Output Slave Unit Participation Flags (48 to 55)							
+13	Bit Input Slave Unit Communications Error Flags (48 to 55)								Bit Input Slave Unit Participation Flags (48 to 55)							
+14	Bit Output Slave Unit Communications Error Flags (56 to 63)								Bit Output Slave Unit Participation Flags (56 to 63)							
+15	Bit Input Slave Unit Communications Error Flags (56 to 63)								Bit Input Slave Unit Participation Flags (56 to 63)							
+16	Bit Output Slave Unit Communications Error Flags (64 to 71)								Bit Output Slave Unit Participation Flags (64 to 71)							
+17	Bit Input Slave Unit Communications Error Flags (64 to 71)								Bit Input Slave Unit Participation Flags (64 to 71)							
+18	Bit Output Slave Unit Communications Error Flags (72 to 79)								Bit Output Slave Unit Participation Flags (72 to 79)							
+19	Bit Input Slave Unit Communications Error Flags (72 to 79)								Bit Input Slave Unit Participation Flags (72 to 79)							
+20	Bit Output Slave Unit Communications Error Flags (80 to 87)								Bit Output Slave Unit Participation Flags (80 to 87)							
+21	Bit Input Slave Unit Communications Error Flags (80 to 87)								Bit Input Slave Unit Participation Flags (80 to 87)							
+22	Bit Output Slave Unit Communications Error Flags (88 to 95)								Bit Output Slave Unit Participation Flags (88 to 95)							
+23	Bit Input Slave Unit Communications Error Flags (88 to 95)								Bit Input Slave Unit Participation Flags (88 to 95)							
+24	Bit Output Slave Unit Communications Error Flags (96 to 103)								Bit Output Slave Unit Participation Flags (96 to 103)							
+25	Bit Input Slave Unit Communications Error Flags (96 to 103)								Bit Input Slave Unit Participation Flags (96 to 103)							

Word (See note.)	Bit															
	15	14	13	12	11	10	09	08	07	06	05	04	03	02	01	00
+26	Bit Output Slave Unit Communica- tions Error Flags (104 to 111)								Bit Output Slave Unit Participation Flags (104 to 111)							
+27	Bit Input Slave Unit Communica- tions Error Flags (104 to 111)								Bit Input Slave Unit Participation Flags (104 to 111)							
+28	Bit Output Slave Unit Communica- tions Error Flags (112 to 119)								Bit Output Slave Unit Participation Flags (112 to 119)							
+29	Bit Input Slave Unit Communica- tions Error Flags (112 to 119)								Bit Input Slave Unit Participation Flags (112 to 119)							
+30	Bit Output Slave Unit Communica- tions Error Flags (120 to 127)								Bit Output Slave Unit Participation Flags (120 to 127)							
+31	Bit Input Slave Unit Communica- tions Error Flags (120 to 127)								Bit Input Slave Unit Participation Flags (120 to 127)							

Note Word +0 is assumed to be the first address set under *Bit Status* on the Master I/O Allocation Tab Page in the software setting by the CompoNet Support Software.

Flag Data Arrangement (Word +0)

	Bits															
	15	14	13	12	11	10	09	08	07	06	05	04	03	02	01	00
Node address	OUT7	OUT6	OUT5	OUT4	OUT3	OUT2	OUT1	OUT0	OUT7	OUT6	OUT5	OUT4	OUT3	OUT2	OUT1	OUT0

Participation and Communications Error Flag Allocation when Expansion Units Are Used

Allocations for the combination of a Basic Unit and Expansion Unit are the same as for a Word Slave Unit of the same size. When inputs and outputs are both included by adding an Expansion Unit, the Unit is treated as an Input Unit. Therefore the Participation Flags and Communications Error Flags corresponding to node address bits in the Input Area are used.

The following examples show flag allocations when an Expansion Unit is connected to a Word Slave Unit at node address m (m = 0, 1, 2, etc.).

Example 1: Basic Unit (16 Inputs) + Expansion Unit (16 Inputs)

Flags for input node m are allocated.

For a Basic Unit (16 inputs) and an Expansion Unit (16 inputs) at node address 0, the flags for IN0 are used.

Word	Communications Error Flags								Participation Flags							
	Bits															
	15	14	13	12	11	10	09	08	07	06	05	04	03	02	01	00
+0																
+1								IN0								IN0
+2																

Example 2: Basic Unit (16 Inputs) + Expansion Unit (16 Outputs)

Flags for input node m are allocated.

For a Basic Unit (16 inputs) and an Expansion Unit (16 outputs) at node address 0, the flags for IN0 are used.

Word address	Bits															
	15	14	13	12	11	10	09	08	07	06	05	04	03	02	01	00
+0																
+1								IN0								IN0
+2																

Example 3: Basic Unit (16 Outputs) + Expansion Unit (16 Inputs)

The Unit is treated the same as a Contact I/O Unit. With Contact I/O Units, only the flags for the input node are allocated. Therefore, in this case as well, only the flags for input node m are allocated.

For a Basic Unit (16 outputs) and an Expansion Unit (16 inputs) at node address 0, the flags for IN0 are used.

Word address	Bits															
	15	14	13	12	11	10	09	08	07	06	05	04	03	02	01	00
+0																
+1								IN0								IN0
+2																

Example 4: Basic Unit (16 Outputs) + Expansion Unit (16 Outputs)

Flags for output node m are allocated.

For a Basic Unit (16 outputs) and an Expansion Unit (16 outputs) at node address 0, the flags for OUT0 are used.

Word address	Bits															
	15	14	13	12	11	10	09	08	07	06	05	04	03	02	01	00
+0								OUT0								OUT0
+1																
+2																

5-3 Remote I/O Communications Performance

This section describes the performance of remote I/O communications in a CompoNet Network.

5-3-1 I/O Response Time

This section describes the minimum and maximum I/O response times in a CompoNet Network.

The I/O response time is the time required for an input signal from an Input Slave Unit to be processed by the Master Unit PLC until it is output to an Output Slave Unit.

Maximum I/O Response Time

Word Slave Units

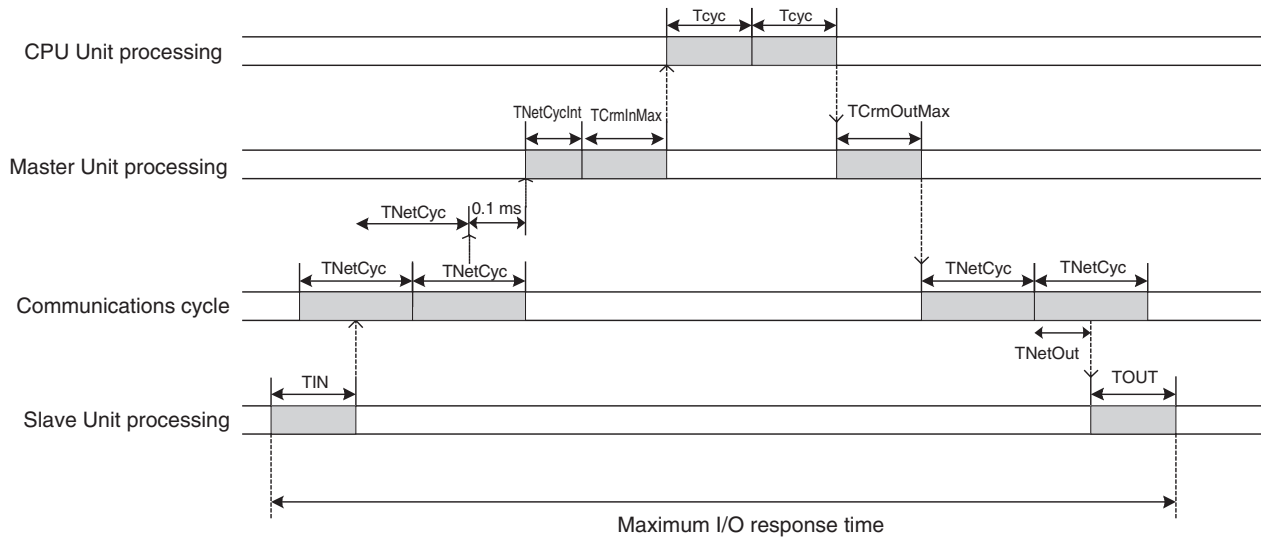

■ **Formula for the Maximum I/O Response Time for a Word Slave Unit**

$$T_{IN} + T_{NetCyc} \times 2 + 0.1\text{ms} + T_{NetCyclnt} + T_{CrmInMax} + T_{cyc} \times 2 + T_{CrmOutMax} + T_{NetOut} + T_{OUT}$$

- T_{IN} : Input Slave Unit input delay time
- T_{NetCyc} : Communications cycle time
- $T_{NetCyclnt}$: Interrupt processing time
- $T_{CrmInMax}$: Maximum input processing time at Master Unit
- T_{cyc} : CPU Unit cycle time
- $T_{CrmOutMax}$: Maximum output processing time at Master Unit
- T_{NetOut} : Time allotted for output frames in communications cycle time
- T_{OUT} : Output Slave Unit output delay time

- Input Slave Unit input delay time
For details on delay times for individual Slave Units, refer to the input specifications for individual Slave Units in the *CompoNet Slave Unit Operation Manual* (Cat. No. W457).
- T_{NetCyc} : Communications Cycle Time

Baud rate Communications mode	Maximum I/O	4.0 Mbit/s	3.0 Mbit/s	1.5 Mbit/s	93.75 kbit/s
Communications mode 0	128 input words, 128 output words	0.9 ms (0.7 ms)	0.9 ms (0.7 ms)	1.5 ms (1.1 ms)	19.6 ms (12.2 ms)
Communications mode 1	256 input words, 256 output words	1.0 ms (0.7 ms)	1.2 ms (1.0 ms)	2.3 ms (1.9 ms)	29.8 ms (22.4 ms)
Communications mode 2	512 input words, 512 output words	1.3 ms (1.0 ms)	1.6 ms (1.4 ms)	4.0 ms (3.5 ms)	50.6 ms (43.2 ms)

Baud rate Communications mode	Maximum I/O	4.0 Mbit/s	3.0 Mbit/s	1.5 Mbit/s	93.75 kbit/s
Communications mode 3	256 input words, 256 output words + 128 bit inputs, 128 bit outputs	2.0 ms (1.8 ms)	2.5 ms (2.3 ms)	5.8 ms (5.4 ms)	70.7 ms (64.4 ms)
Communications mode 8	1,024 input words, 1,024 output words + 256 input bits, 256 output bits Note The number of connectable nodes is 128 for Word Slave Units (64 input and 64 output) and 256 for Bit Slave Units (128 bit input and 128 bit output).	0.55 ms + G (0.55 ms + G) (See note.)	0.66 ms + G (0.66 ms + G) (See note.)	1.58 ms + G (1.58 ms + G) (See note.)	21.09 ms + G (21.09 ms + G) (See note.)

The figures in parentheses are when message communications are not used.

- Note** Communications Mode 8
 G = (Number of Word Output Slave Units connected × additional time per Word Output Slave Unit)
 + (Number of Word Input Slave Units × additional time per Word Input Slave Unit)
 + (Number of Bit Output Slave Units × additional time per Bit Output Slave Unit)
 + (Number of Bit Input Slave Units × additional time per Bit Input Slave Unit)

Additional Time Per Unit by Slave Unit Type

Baud rate Slave Unit type	4.0 Mbit/s	3.0 Mbit/s	1.5 Mbit/s	93.75 kbit/s
Word Output Unit	5.97 μs	7.43 μs	15.98 μs	189.27 μs
Word Input Unit	20.23 μs	26.07 μs	54.85 μs	727.34 μs
Bit Output Unit	2.38 μs	2.77 μs	6.64 μs	39.39 μs
Bit Input Unit	15.38 μs	19.94 μs	42.89 μs	538.5 μs

G Calculation Example

Conditions

Baud rate	Word outputs	Word inputs	Bit outputs	Bit inputs
4.0 Mbit/s	16 Units	32 Units	64 Units	32 Units

$$G = (16 \times 5.97 \mu s) + (32 \times 20.23 \mu s) + (64 \times 2.38 \mu s) + (32 \times 15.38 \mu s) \cong 1.387 \text{ ms}$$

- 0.1 ms: Interval for inputting input data
- TNetCyclnt: Interrupt processing time

Baud rate Communications mode	4.0 Mbit/s	3.0 Mbit/s	1.5 Mbit/s	93.75 kbit/s
Communications mode 0	0.40 ms	0.45 ms	0.60 ms	6.90 ms
Communications mode 1	0.42 ms	0.48 ms	0.68 ms	6.98 ms
Communications mode 2	0.48 ms	0.53 ms	0.82 ms	7.11 ms

Baud rate	4.0 Mbit/s	3.0 Mbit/s	1.5 Mbit/s	93.75 kbit/s
Communications mode				
Communications mode 3	0.63 ms	0.69 ms	0.98 ms	7.28 ms
Communications mode 8	0.37 ms + H (See note.)	0.43 ms + H (See note.)	0.73 ms + H (See note.)	7.03 ms + H (See note.)

Note Communications Mode 8
 $H = (\text{Number of Word Output Slave Units} \times 0.313 \mu\text{s}) + (\text{Number of Word Input Slave Units} \times 3.125 \mu\text{s}) + (\text{Number of Bit Output Slave Units} \times 0.078 \mu\text{s}) + (\text{Number of Bit Input Slave Units} \times 3.125 \mu\text{s})$

H Calculation Example

Conditions

Baud rate	Word outputs	Word inputs	Bit outputs	Bit inputs
---	32 nodes	64 nodes	48 nodes	16 nodes

$$H = (32 \times 0.313 \mu\text{s}) + (64 \times 3.125 \mu\text{s}) + (48 \times 0.078 \mu\text{s}) + (16 \times 3.125 \mu\text{s}) \cong 0.264 \text{ ms}$$

- TCrmlnMax: Maximum input processing time at Master Unit

Baud rate	4.0 Mbit/s	3.0 Mbit/s	1.5 Mbit/s	93.75 kbit/s
Communications mode				
Communications mode 0	0.3 ms	0.28 ms	0.26 ms	0.22 ms
Communications mode 1	0.31 ms	0.29 ms	0.27 ms	0.27 ms
Communications mode 2	0.35 ms	0.33 ms	0.37 ms	0.37 ms
Communications mode 3	0.34 ms	0.34 ms	0.38 ms	0.38 ms
Communications mode 8	0.29 ms + I (See note.)	0.29 ms + I (See note.)	0.33 ms + I (See note.)	0.35 ms + I (See note.)

Note Communications Mode 8
 $I = (\text{Number of Word Input Slave Units} \times 0.625 \mu\text{s}) + [(\text{Number of Word Output Slave Units or Word Input Slave Units, whichever is greater}) + (\text{Number of Bit Output Slave Units or Bit Input Slave Units, whichever is greater}) \times 0.5 \mu\text{s}]$

I Calculation Example

Conditions

Baud rate	Word outputs	Word inputs	Bit outputs	Bit inputs
---	48 nodes	32 nodes	64 nodes	128 nodes

$$I = (32 \times 0.625 \mu\text{s}) + \{(48 + 128) \times 0.5 \mu\text{s}\} = 0.108 \text{ ms}$$

- Tcyc: CPU Unit cycle time
- TCrmoMax: Maximum output processing time at Master Unit

Communications mode 0	Communications mode 1	Communications mode 2	Communications mode 3	Communications mode 8
0.086 ms	0.090 ms	0.098 ms	0.094 ms	0.082 ms + J (See note.)

Note Communications Mode 8
 $J = (\text{Number of Word Output Slave Units} \times 0.5 \mu\text{s}) + (\text{Number of Bit Output Slave Units} \times 0.0625 \mu\text{s})$

J Calculation Example

Conditions

Baud rate	Word outputs	Word inputs	Bit outputs	Bit inputs
---	16 nodes	48 nodes	8 nodes	8 nodes

$$J = (16 \times 0.5 \mu\text{s}) + (8 \times 0.0625 \mu\text{s}) \cong 0.009 \text{ ms}$$

- TNetOut: Time allotted for output frames in communications cycle time

Baud rate	Maximum I/O	4.0 Mbit/s	3.0 Mbit/s	1.5 Mbit/s	93.75 kbit/s
Communications mode 0					
Communications mode 0	128 input words, 128 output words	0.046 ms	0.060 ms	0.121 ms	1.936 ms
Communications mode 1	256 input words, 256 output words	0.078 ms	0.103 ms	0.206 ms	3.305 ms
Communications mode 2	512 input words, 512 output words	0.142 ms	0.188 ms	0.377 ms	6.048 ms
Communications mode 3	256 input words, 256 output words + 128 bit inputs, 128 bit outputs	0.110 ms	0.146 ms	0.291 ms	4.674 ms
Communications mode 8	1,024 word inputs, 1,024 word outputs + 256 bit inputs, 256 bit outputs Note The number of connectable nodes is 128 for Word Slave Units (64 input and 64 output) and 256 for Bit Slave Units (128 bit input and 128 bit output).	0.13 ms + K (See note.)	0.018 ms + K (See note.)	0.035 ms + K (See note.)	0.567 ms + K (See note.)

Note Communications Mode 8
 $K = (\text{Number of Word Output Slave Units connected} \times \text{additional time per Word Output Slave Unit}) + [(\text{Number of Bit Output Slave Units} + 7) \div 8] \times \text{additional time per 8 Bit Output Slave Units}$

Additional time per Word Output Slave Unit / Additional time per 8 Bit Output Slave Units

Baud rate	4.0 Mbit/s	3.0 Mbit/s	1.5 Mbit/s	93.75 kbit/s
Communications mode				
Word Output	4.0 μs	5.312 μs	10.656 μs	171.104 μs
Bit Output	4.0 μs	5.312 μs	10.656 μs	171.104 μs

K Calculation Example

Conditions

Baud rate	Word outputs	Word inputs	Bit outputs	Bit inputs
3.0 Mbit/s	7 Units	8 Units	9 Units	10 Units

$$K = (7 \times 5.312 \mu\text{s}) + (2 \times 5.312 \mu\text{s}) \cong 0.048 \text{ ms}$$

- TOUT: Output Slave Unit output delay time
 For details on delay times for individual Slave Units, refer to the output specifications for individual Slave Units in the *CompoNet Slave Unit Operation Manual* (Cat. No. W457).

■ Reference Example

The following table shows the calculation results for the maximum I/O response time for a Word Slave Unit with the maximum number of nodes and a CPU Unit cycle time of 1 ms.

Communications mode	Number of nodes connected	Word Slave Unit max. I/O response time (ms)			
		4.0 Mbit/s	3.0 Mbit/s	1.5 Mbit/s	93.75 kbit/s
Communications mode 0	16 word nodes (8 input, 8 output)	7.7	7.9	9.2	53.4
Communications mode 1	32 word nodes (16 input, 16 output)	7.9	8.3	10.9	75.3
Communications mode 2	64 word nodes (32 input, 32 output)	8.7	9.5	14.8	119.9
Communications mode 3	32 word nodes (16 input, 16 output) 128 bit nodes (64 bit input, 64 bit output)	10.3	11.4	18.4	158.9
Communications mode 8	128 word nodes (64 input, 64 output) 256 bit nodes (128 bit input, 128 bit output)	15.8	18.5	32.8	337.9

(With message communications)

Bit Slave Units

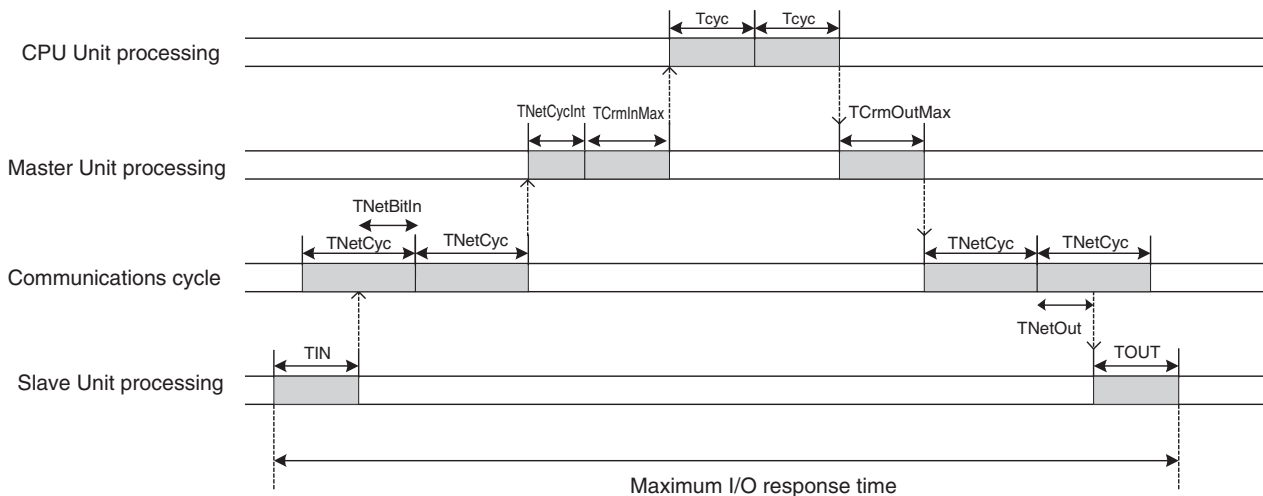

■ Formula for the Maximum I/O Response Time for a Bit Slave Unit

$$T_{IN} + T_{NetCyc} \times 2 + T_{NetBitIn} + T_{NetCyclInt} + T_{CrmInMax} + T_{cyc} \times 2 + T_{CrmOutMax} + T_{NetOut} + T_{OUT}$$

- TIN: Input Slave Unit input delay time
- TNetCyc: Communications cycle time
- TNetBitIn: Time allotted for bit input frames in communications cycle time
- TNetCyclInt: Interrupt processing time
- TCrmInMax: Maximum input processing time at Master Unit
- Tcyc: CPU Unit cycle time
- TCrmOutMax: Maximum output processing time at Master Unit
- TNetOut: Time allotted for output frames in communications cycle time
- TOUT: Output Slave Unit output delay time

- TIN: Input Slave Unit input delay time
For details on input delay times for individual Slave Units, refer to the input specifications for individual Slave Units in the *CompoNet Slave Unit Operation Manual* (Cat. No. W457).
- TNetBitIn: Time allotted for bit Input frames in communications cycle time

Baud rate	Maximum I/O	4.0 Mbit/s	3.0 Mbit/s	1.5 Mbit/s	93.75 kbit/s
Communications mode 3	256 input words, 256 output words + 128 bit inputs, 128 bit outputs	0.792 ms	1.052 ms	2.276 ms	32.226 ms
Communications mode 8	1,024 input words, 1,024 output words + 256 bit inputs, 256 bit outputs	0.013 μs × (Number of Bit Input Slave Units)	0.017 μs × (Number of Bit Input Slave Units)	0.037 μs × (Number of Bit Input Slave Units)	0.518 μs × (Number of Bit Input Slave Units)

- TCrmInMax: Maximum input processing time at Master Unit

Baud rate	4.0 Mbit/s	3.0 Mbit/s	1.5 Mbit/s	93.75 kbit/s
Communications mode 3	0.35 ms	0.35 ms	0.39 ms	0.39 ms
Communications mode 8	0.25 ms + M (See note.)	0.27 ms + M (See note.)	0.33 ms + M (See note.)	0.35 ms + M (See note.)

Note Communications Mode 8
 $M = (\text{Number of Word Input Slave Units} \times 0.625 \mu\text{s}) + \{[(\text{Number of Bit Input Slave Units} \times 7) \div 8] \times 0.375 \mu\text{s}\} + [(\text{Number of Word Output Slave Units or Word Input Slave Units, whichever is greater}) + (\text{Number of Bit Output Slave Units and Bit Input Slave Units, whichever is greater}) \times 0.5 \mu\text{s}]$

M Calculation Example

Conditions

Baud rate	Word outputs	Word inputs	Bit outputs	Bit inputs
---	8 nodes	16 nodes	16 nodes	8 nodes

$$M = (16 \times 0.625 \mu\text{s}) + (1 \times 0.375 \mu\text{s}) + \{(16 + 16) \times 0.5 \mu\text{s}\} \cong 0.027 \text{ ms}$$

■ Reference Example

The following table shows the calculation results for the maximum I/O response time for a Bit Slave Unit with the maximum number of nodes and a CPU Unit cycle time of 1 ms.

Communications mode	Number of nodes connected	Word Slave Unit max. I/O response time (ms)			
		4.0 Mbit/s	3.0 Mbit/s	1.5 Mbit/s	93.75 kbit/s
Communications mode 3	32 word nodes (16 input, 16 output) 128 bit nodes (64 bit input, 64 bit output)	10.7	12.1	20.3	190.8
Communications mode 8	128 word nodes (64 input, 64 output) 256 bit nodes (128 bit input, 128 bit output)	15.1	18.3	35.2	401.8

(With message communications)

Minimum I/O Response Time

Word Slave Units

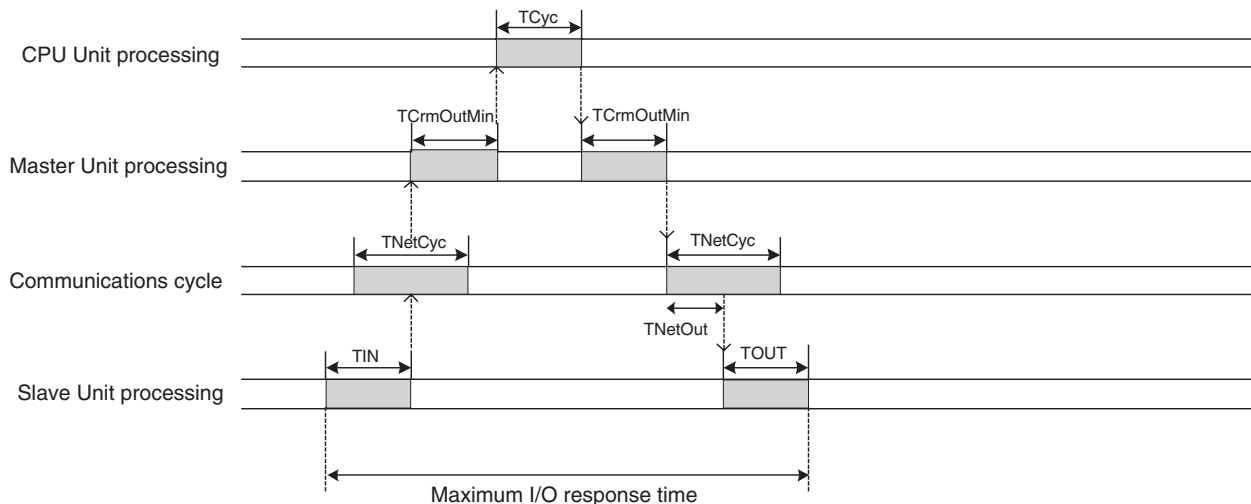

■ **Formula for Word Slave Minimum I/O Response Time**

$$TIN + TCrmInMin + Tcyc + TCrmOutMin + TNetOut + TOUT$$

- TIN: Input Slave Unit input delay time
- TCrmInMin: Minimum input processing time at Master Unit
- Tcyc: CPU Unit cycle time
- TCrmOutMin: Minimum output processing time at Master Unit
- TNetOut: Time allotted for output frames in communications cycle time
- TOUT: Output Slave Unit output delay time

- TCrmOutMin: Minimum output processing time at Master Unit

Communications mode 0	Communications mode 1	Communications mode 2	Communications mode 3	Communications mode 8
0.05 ms	0.055 ms	0.06 ms	0.06 ms	0.045 ms + N (See note.)

Note Communications Mode 8
 $N = (\text{Number of Word Output Slave Units} \times 0.5 \mu\text{s}) + (\text{Number of Bit Output Slave Units} \times 0.0625 \mu\text{s})$

N Calculation Example

Conditions

Baud rate	Word outputs	Word inputs	Bit outputs	Bit inputs
---	48 nodes	32 nodes	16 nodes	8 nodes

$$N = (48 \times 0.5 \mu\text{s}) + (16 \times 0.0625 \mu\text{s}) = 0.025 \text{ ms}$$

- TCrmInMin: Minimum input processing time at Master Unit

Communications mode 0	Communications mode 1	Communications mode 2	Communications mode 3	Communications mode 8
0.023 ms	0.025 ms	0.029 ms	0.025 ms	0.021 ms + O (See note.)

Note Communications Mode 8
 $O = (\text{Number of Word Input Slave Units} \times 0.25 \mu\text{s})$

O Calculation Example

Conditions

Baud rate	Word outputs	Word inputs	Bit outputs	Bit inputs
---	8 nodes	16 nodes	32 nodes	48 nodes

$$O = 16 \times 0.25 \mu s = 0.004 \text{ ms}$$

■ Reference Example

The following table shows the calculation results for the minimum I/O response time for a Word Slave Unit with the maximum number of nodes and a CPU Unit cycle time of 1 ms.

Communications mode	Number of nodes connected	Word Slave Unit max. I/O response time (ms)			
		4.0 Mbit/s	3.0 Mbit/s	1.5 Mbit/s	93.75 kbit/s
Communications mode 0	16 word nodes (8 input, 8 output)	4.2	4.2	4.2	6.0
Communications mode 1	32 word nodes (16 input, 16 output)	4.2	4.2	4.3	7.4
Communications mode 2	64 word nodes (32 input, 32 output)	4.3	4.3	4.7	10.2
Communications mode 3	32 word nodes (16 input, 16 output) 128 bit nodes (64 bit input, 64 bit output)	4.2	4.3	4.4	8.8
Communications mode 8	128 word nodes (64 input, 64 output) 256 bit nodes (128 bit input, 128 bit output)	4.5	4.6	5.0	18.4

Bit Slave Units

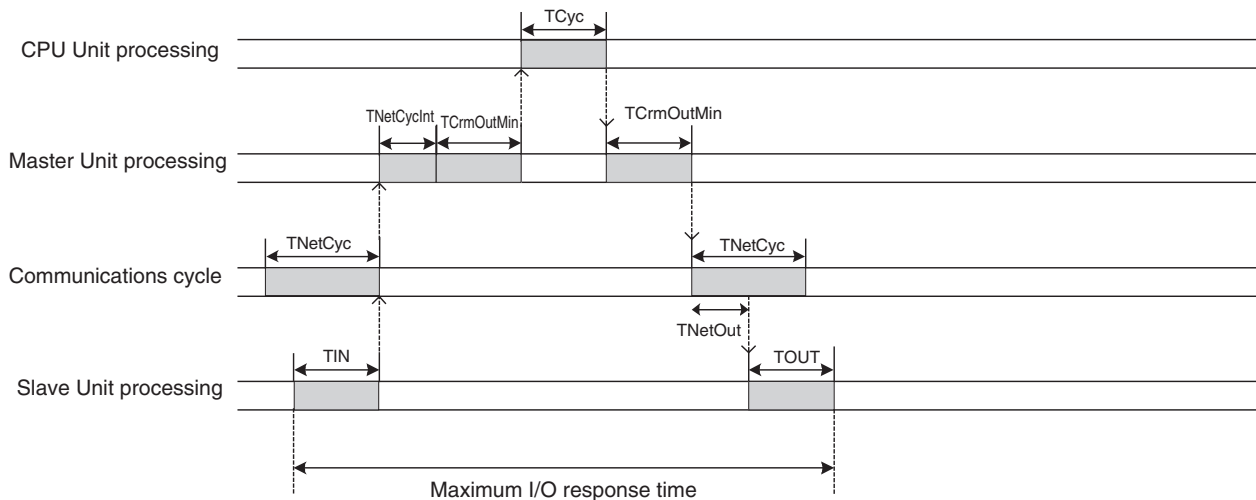

■ Formula for the Minimum I/O Response Time for a Bit Slave Unit

$$TIN + TNetCyclnt + TCrmInMin + Tcyc + TCrmOutMin + TNetOut + TOUT$$

- TIN: Input Slave Unit input delay time
- TNetCyclnt: Interrupt processing time
- TCrmInMin: Minimum input processing time at Master Unit
- Tcyc: CPU Unit cycle time
- TCrmOutMin: Minimum output processing time at Master Unit
- TNetOut: Time allotted for output frames in communications cycle time
- TOUT: Output Slave Unit output delay time

- TCrmInMin: Minimum input processing time at Master Unit

Communications mode 3	Communications mode 8
0.093 ms	0.46 ms + P (See note.)

Note Communications Mode 8

$P = (\text{Number of Word Input Slave Units} \times 0.25 \mu\text{s}) + \{[(\text{Number of Bit Input Slave Units} \times 7) \div 8] \times 0.375 \mu\text{s}\} + [(\text{Number of Word Output Slave Units or Word Input Slave Units, whichever is greater}) + (\text{Number of Bit Output Slave Units and Bit Input Slave Units, whichever is greater}) \times 0.5 \mu\text{s}]$

P Calculation Example

Conditions

Baud rate	Word outputs	Word inputs	Bit outputs	Bit inputs
---	63 nodes	64 nodes	128 nodes	127 nodes

$$P = (64 \times 0.25 \mu\text{s}) + (16 \times 0.375 \mu\text{s}) + ((64 + 128) \times 0.5 \mu\text{s}) = 0.118 \text{ ms}$$

■ Reference Example

The following table shows the calculation results for the maximum I/O response time for a Bit Slave Unit with the minimum number of nodes and a CPU Unit cycle time of 1 ms.

Communications mode	Number of nodes connected	Word Slave Unit max. I/O response time (ms)			
		4.0 Mbit/s	3.0 Mbit/s	1.5 Mbit/s	93.75 kbit/s
Communications mode 3	32 word nodes (16 input, 16 output) 128 bit nodes (64 bit input, 64 bit output)	4.9	5.0	5.5	16.2
Communications mode 8	128 word nodes (64 input, 64 output) 256 bit nodes (128 bit input, 128 bit output)	5.7	5.9	6.6	26.3

5-3-2 Effects of Master Units on CPU Unit Cycle Time

CPU Unit cycle time is affected by the number of Master Units mounted and the communications mode that is used (e.g., the number of words allocated for Slave Units in the I/O Memory Area when communications mode 8 is used).

The following tables show the additional time per Master Unit on CPU Unit cycle time for each communications mode.

CS Series

Communications mode CPU Unit model	Communications mode 0	Communications mode 1	Communications mode 2	Communications mode 3	Communications mode 8
CS1G CPU Unit	0.244 ms	0.278 ms	0.344 ms	0.367 ms	0.180 + (0.0024 x number of words allocated) ms
CS1G-H CPU Unit	0.189 ms	0.211 ms	0.233 ms	0.289 ms	0.135 + (0.0014 x number of words allocated) ms
CS1H CPU Unit	0.200 ms	0.233 ms	0.300 ms	0.311 ms	0.150 + (0.0022 x number of words allocated) ms
CS1H-H CPU Unit	0.156 ms	0.167 ms	0.200 ms	0.244 ms	0.105 + (0.0012 x number of words allocated) ms

Note The number of words allocated is number of words actually allocated in the I/O Memory Area for all connected Slave Units.

CJ Series

Communications mode CPU Unit model	Communications mode 0	Communications mode 1	Communications mode 2	Communications mode 3	Communications mode 8
CJ1G CPU Unit	0.200 ms	0.256 ms	0.300 ms	0.322 ms	$0.154 + (0.0022 \times \text{number of words allocated})$ ms
CJ1G-H CPU Unit	0.189 ms	0.211 ms	0.233 ms	0.289 ms	$0.109 + (0.0014 \times \text{number of words allocated})$ ms
CJ1H-H CPU Unit	0.156 ms	0.178 ms	0.189 ms	0.244 ms	$0.106 + (0.0012 \times \text{number of words allocated})$ ms
CJ1M CPU Unit (Low-end model CJ1M-CPU11/ CPU21)	0.256 ms	0.267 ms	0.289 ms	0.367 ms	$0.166 + (0.0016 \times \text{number of words allocated})$ ms
CJ1M CPU Unit (Other than low-end model)	0.233 ms	0.256 ms	0.267 ms	0.322 ms	$0.100 + (0.0016 \times \text{number of words allocated})$ ms

Note The number of words allocated is number of words actually allocated in the I/O Memory Area for all connected Slave Units.

SECTION 6

Message Communications

This section describes the message communications that are possible with CompoNet Networks.

6-1	Message Communications	168
6-1-1	Overview.....	168
6-1-2	FINS Message Communications	168
6-1-3	Explicit Message Communications	169
6-1-4	Message Communications Specifications	169
6-1-5	Message Monitoring Timer	169
6-2	Overview of FINS Commands and Responses	170
6-2-1	FINS Communications Service	170
6-2-2	Sending and Receiving FINS Commands and Responses	170
6-2-3	Units That Can Process FINS Commands and Responses	171
6-2-4	FINS Command List.....	171
6-3	Using FINS Message Communications	172
6-3-1	Instructions for Sending FINS Commands.....	172
6-3-2	Using CMND(490).....	173
6-4	Sending Explicit Messages	175
6-4-1	Sending Explicit Messages.....	176
6-4-2	Using CMND(490) to Send Explicit Messages	178

6-1 Message Communications

The message communications function sends and receives data between nodes on a CompoNet Network, i.e., between the PLC's CPU Unit and the Master Unit and between the PLC's CPU Unit and CompoNet Slave Units. Message communications are used to read and write special data, such as time or error history information, and to control operation, e.g., by force-setting/resetting bits. Message communications are performed whenever required, i.e., when the conditions set for their execution are satisfied.

There are two types of message communications: FINS message communications and explicit message communications.

6-1-1 Overview

	FINS message communications	Explicit message communications
Overview	Message communications developed by OMRON using the FINS protocol	General-purpose message communications using the CompoNet Network protocol
Remote devices	OMRON PLCs	CompoNet Slave Units
Features	<ul style="list-style-type: none"> FINS commands can be sent and received to implement a wider range of services than is possible with explicit messages. FINS commands provide transparent message communications with nodes on other OMRON networks (Controller Link, SYSMAC LINK, Ethernet, and DeviceNet) across a maximum of three network layers. 	<ul style="list-style-type: none"> Explicit messages can be received from OMRON PLCs and they can be sent to CompoNet Slave Units.

6-1-2 FINS Message Communications

Messages using FINS commands can be exchanged with CompoNet Master Units that support FINS messages.

CS/CJ-series CompoNet Master Units can freely exchange message communications with nodes on other networks (such as Controller Link, SYSMAC LINK, and Ethernet). Communications are possible across a maximum of three network layers. Routing tables must be registered, however, in the CPU Unit of each PLC on the network, including the local and relay network tables.

CompoNet Master Units are not included in those routing tables.

FINS communications are possible across a maximum of three layers, with CompoNet Master Units at the ends.

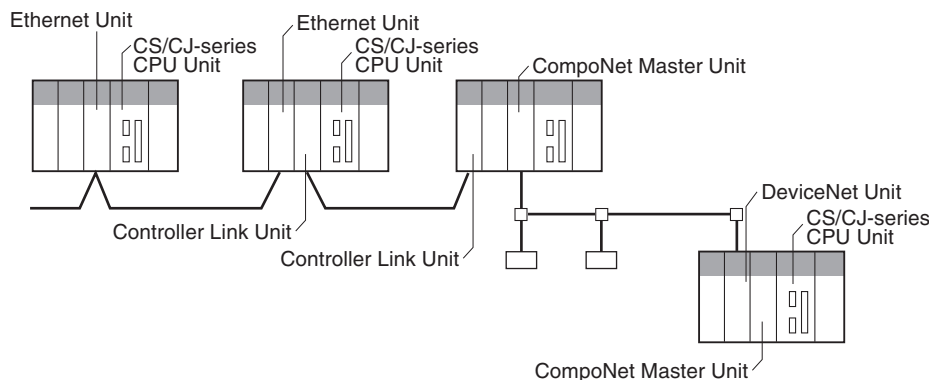

6-1-3 Explicit Message Communications

Explicit messages defined by the CompoNet Network are used to send requests for services to CompoNet Slave Units.

Explicit messages are sent using FINS commands (command code 2802).

6-1-4 Message Communications Specifications

Applicable PLC series		CS/CJ Series
Unit models		CS1W-CRM21 and CJ1W-CRM21
Maximum number of nodes per Master Unit for message communications	Explicit messages	448
Instructions for executing message communications	Any FINS commands	CMND(490) instruction (FINS message sent to CompoNet Master Unit)
	CompoNet explicit messages	CMND(490) instruction (FINS message sent to CompoNet Slave Unit)
Command transmission sources: Transmission destinations		1:1 communications (1:N broadcast communications are not possible.)
Communications data length (not including command code)		CMND(490) instruction: 542 bytes max.
Number of instructions executed simultaneously		One for each of eight ports (ports 0 to 7) Note For information on ports (logical ports), refer to the section on instructions for network communications in the CS/CJ-series PLC Instruction Reference Manual (Cat. No. W340)
Response monitoring time		Default setting: 2 s; user setting: 0.1 to 6,553.5 s
Number of retries		0 to 15
Message monitoring timer (explicit message communications)		With explicit message communications, the response monitoring time of the CompoNet Master Unit can be set from the CompoNet Support Software. (The setting is recorded in the CompoNet Master Unit.)

6-1-5 Message Monitoring Timer

The message monitoring timer measures the monitoring time for responses made by the CompoNet Master Unit. It is enabled for explicit message communications. It can be set from the CompoNet Support Software. The default setting is for 2 s (2,000 ms). Any time from 1 to 65,535 ms can be set.

A longer time must be set if responses from the communications target device (the message transmission destination) are slow. If the set time is too long, however, subsequent messages cannot be sent to the same communications device while waiting for a response to a previous message.

The CompoNet Master Unit monitors message timeouts using this timer. Likewise, monitoring is performed by the CPU Unit according to the response monitoring time for the DELIVER COMMAND (CMND(490)) instructions. It is therefore not effective to lengthen (or shorten) only the message monitoring timer or only the response monitoring time for CMND(490).

Set the response monitoring time for CMND(490) to a value equal to or greater than the time set for the response monitoring timer.

If too many timeouts are occurring, then lengthen the times for both while maintaining the time settings relative to each other.

6-2 Overview of FINS Commands and Responses

6-2-1 FINS Communications Service

FINS communications uses a communications protocol that was developed by OMRON for its factory automation (FA) control systems.

For information on FINS commands, refer to the CS/CJ-series PLC Communications Command Reference Manual (Cat. No. W342).

6-2-2 Sending and Receiving FINS Commands and Responses

FINS commands are sent using CMND(490) for CS/CJ-series PLCs.

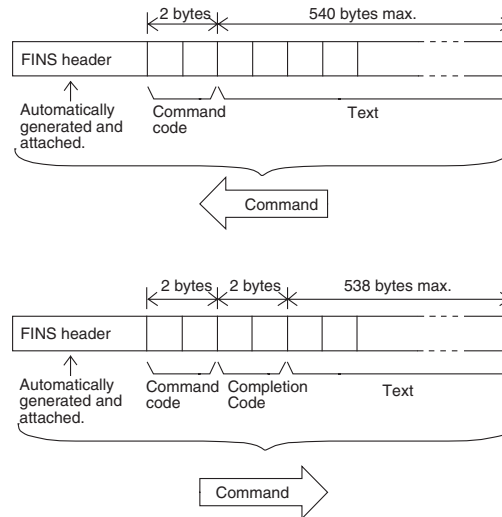

Command Code

The command code is a 2-byte code that indicates the contents of the command. A FINS command must begin with a 2-byte command code. If there are parameters, they are included after the command code.

Completion Code

The Completion Code is a 2-byte code that indicates the execution results of the command. The main response code (MRES) in the first byte of the Completion Code classifies the execution results, and the sub-response code (SRES) in the next byte provides detailed results.

The following table shows the correspondence between execution results and the MRES. For details on Completion Codes including sub-response codes (SRES) and on error processing, refer to the CS/CJ-series Communications Command Reference Manual (Cat. No. W342).

MRES	Execution result	MRES	Execution result
00	Normal completion	20	Read not possible
01	Local node error	21	Write not possible
02	Remote node error	22	Operating mode error
03	Controller error	23	No such Unit
04	Unsupported setting error (service not supported)	24	Start/stop not possible
05	Routing error	25	Unit error
10	Command format error	26	Command error
11	Parameter error	30	Access control error
		40	Service aborted

6-2-3 Units That Can Process FINS Commands and Responses

The number of parameters and types of FINS commands that are supported depend on the Unit directly processing the command. For details on commands and responses to CompoNet Master Units, refer to the Appendix FINS Commands Addressed to CompoNet Master Units and Responses.

For information on commands and responses to CS/CJ-series CPU Units, refer to the CS/CJ Series Communications Command Reference Manual (Cat. No. W342).

6-2-4 FINS Command List

Commands Addressed to CompoNet Master Units

Command	Command code
START I/O COMMUNICATIONS	04 01
RESET UNIT	04 03
READ CONTROLLER DATA	05 01
ECHOBACK TEST	08 01
READ ERROR LOG	21 02
CLEAR ERROR LOG	21 03

CompoNet SEND EXPLICIT MESSAGE Command

Command	Command code
SEND EXPLICIT MESSAGE	28 02

6-3 Using FINS Message Communications

Execute CMND(490) to send a FINS command.

6-3-1 Instructions for Sending FINS Commands

CMND(490)

Control operations, such as reading or writing I/O memory data at another node, reading status information, and changing operating modes, can be performed by executing CMND(490) in the user program in a CS/CJ-series CPU Unit to send a FINS command.

Command data (n bytes) is sent from local node S to address N. The response data (m bytes) is stored from local node address D onwards.

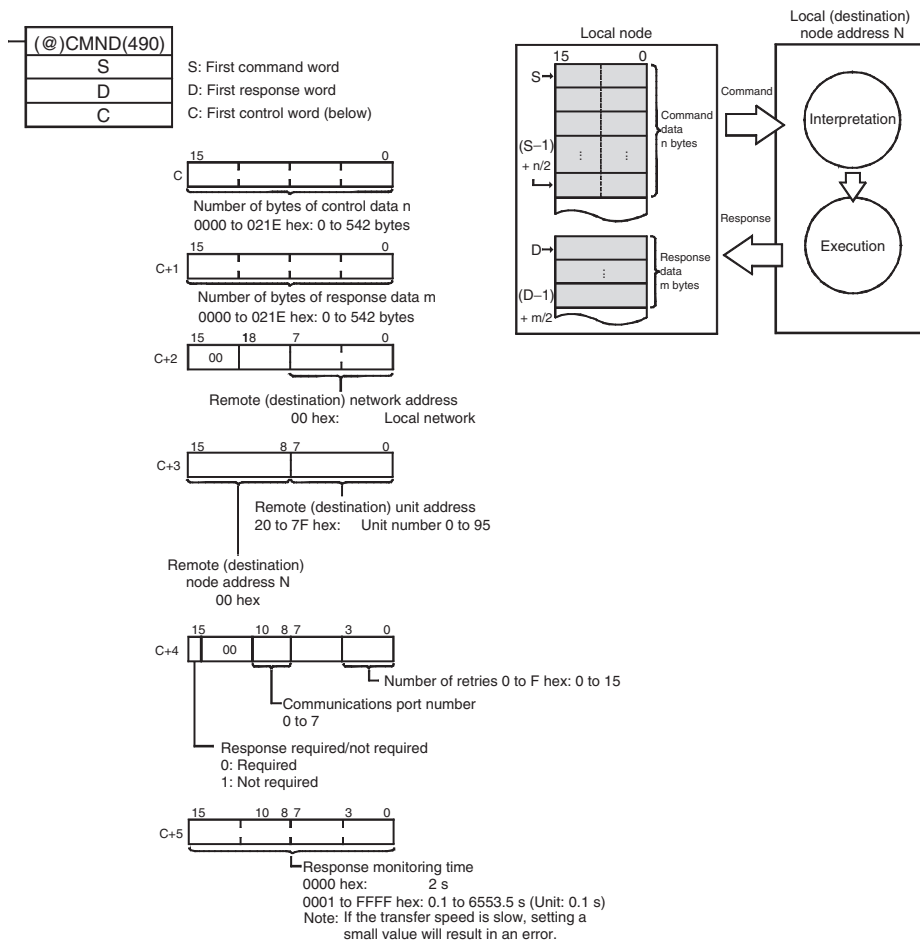

Note If the remote node is a CompoNet Slave Unit, CompoNet explicit messages can be sent by setting "28 02" as the FINS command code.

When doing so, set the response monitoring time in C+5 to a value no lower than the message monitoring timer value (default: 2 s). If it is set to a lower value, the next command sent after a timeout may encounter a busy signal.

6-3-2 Using CMND(490)

With CMND(490), normally the Network Communications Enable Flag at the CPU Unit (bits 00 to 07 of word A202, corresponding to ports 0 to 7) is used as the input condition as shown below.

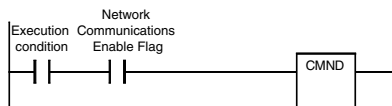

Communications Flags

Type	Flag name	Address		Contents																
		Word	Bits																	
Flags at PLC	Network Communications Enable Flag	A202	<table border="1"> <tr><td>7</td><td>6</td><td>5</td><td>4</td><td>3</td><td>2</td><td>1</td><td>0</td></tr> <tr><td>Port 7</td><td>Port 6</td><td>Port 5</td><td>Port 4</td><td>Port 3</td><td>Port 2</td><td>Port 1</td><td>Port 0</td></tr> </table>	7	6	5	4	3	2	1	0	Port 7	Port 6	Port 5	Port 4	Port 3	Port 2	Port 1	Port 0	0: Enabled (Executing) 1: Disabled (Not executing)
	7	6	5	4	3	2	1	0												
Port 7	Port 6	Port 5	Port 4	Port 3	Port 2	Port 1	Port 0													
	Network Communications Error Flag	A219	<table border="1"> <tr><td>7</td><td>6</td><td>5</td><td>4</td><td>3</td><td>2</td><td>1</td><td>0</td></tr> <tr><td>Port 7</td><td>Port 6</td><td>Port 5</td><td>Port 4</td><td>Port 3</td><td>Port 2</td><td>Port 1</td><td>Port 0</td></tr> </table>	7	6	5	4	3	2	1	0	Port 7	Port 6	Port 5	Port 4	Port 3	Port 2	Port 1	Port 0	0: Normal completion 1: Error
7	6	5	4	3	2	1	0													
Port 7	Port 6	Port 5	Port 4	Port 3	Port 2	Port 1	Port 0													

Communications Flag Operation

- The Network Communications Enable Flag turns OFF when a send or receive instruction is being executed (from when the instruction is executed until a response is received), and ON after the execution has been completed (for either a normal completion or an error).
- The Network Communications Error Flag retains its status until the next transmission or reception is executed.
- The Network Communications Error Flag turns OFF when the next communications instruction is executed even if there is an error.

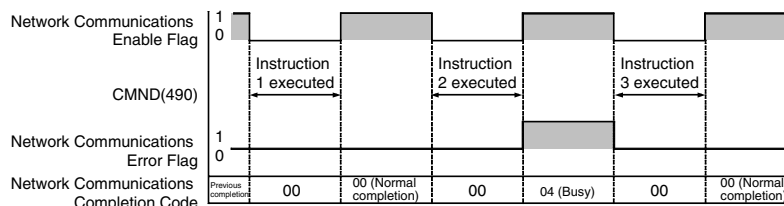

Network Communications Completion Code

When execution of a network communications instruction has been completed, the status is stored in the following words as a Completion Code (FINS command end code). While the network communications instruction is being executed, the value is 00 or 0000 hex, and when execution has been completed the Completion Code is updated.

Word	Contents
A203	Port 0 Network Communications Completion Code
}	}
A210	Port 7 Network Communications Completion Code

Note In the CS/CJ Series, CMND(490) execution result is stored as one word (two bytes) of data. The Network Communications Completion Code is the same as the FINS command end code. Bits 08 to 15 of the Network Communications Completion Code correspond to the first byte, and bits 00 to 07 correspond to the second byte.

Response Read Timing

Read the response when the Network Communications Enable Flag for the port turns ON, as shown below.

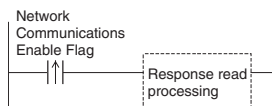

Example: FINS Command Sent using CMND(490)

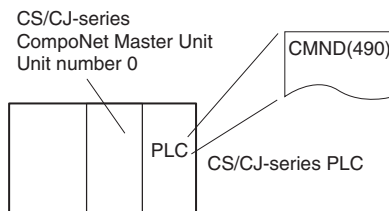

Operation

- Here, controller data is read from the CompoNet Master Unit.
- READ CONTROLLER DATA (0501) is used to read the data.
- The command data is written to D01000 onwards in the CPU Unit of the PLC to which the CompoNet Master Unit is connected, and the response data is stored in D02000 onwards.
- If the command results in an error, the completion code is stored in D00006 and the command is sent again.

Command Details

[CMND S D C]			
S	D01000	+0	: 0501 hex Command code
D	D02000		: First response word
C	D00000	+0	: 0002 hex Number of command data bytes
	+1		: 002E hex Number of response data bytes: 46
	+2		: 0000 hex Remote (destination) network address
	+3		: 0020 hex Remote (destination) node address: 00 hex Remote (destination) unit address: 20 hex
	+4		: 0000 hex Response: Required; Communications port No.: 0; Number of retries: 0 hex
	+5		: 0064 hex Response monitoring time

Program Example

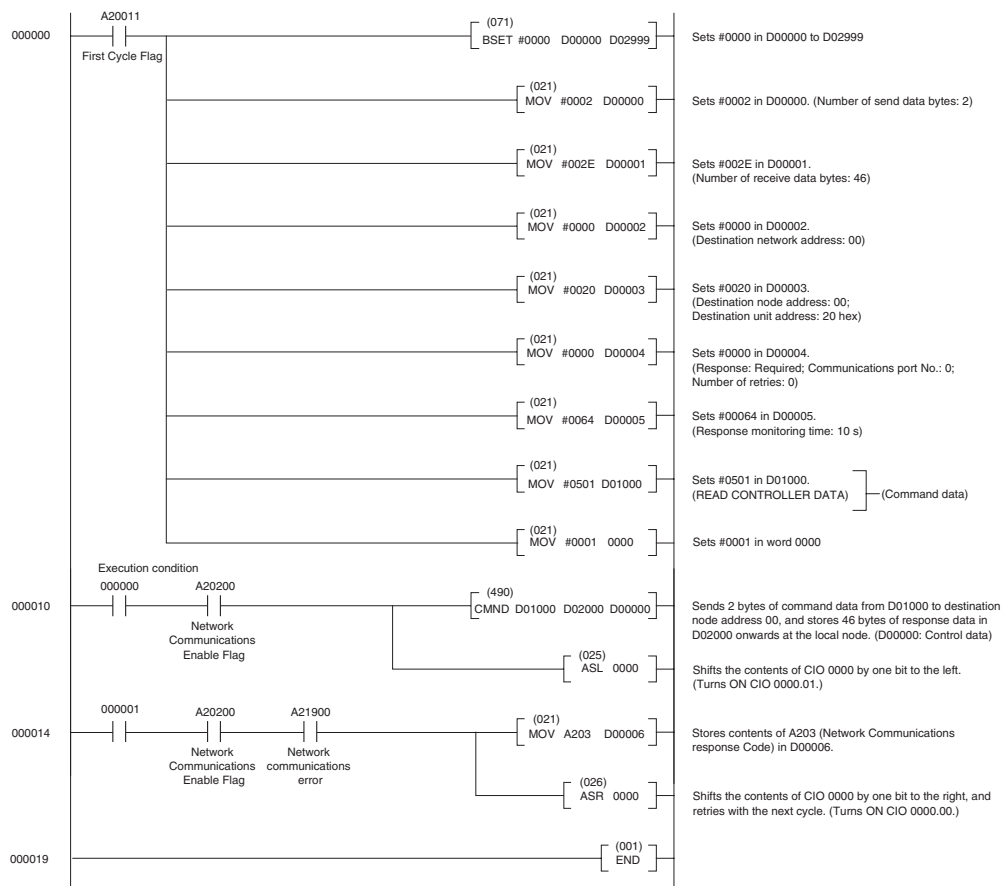

6-4 Sending Explicit Messages

Explicit messages can be sent using a CS/CJ-series CompoNet Master Unit. A explicit message is sent with a FINS command header attached.

Explicit messages can be sent to CompoNet Slave Units, as shown below.

- CompoNet Slave Units
Example

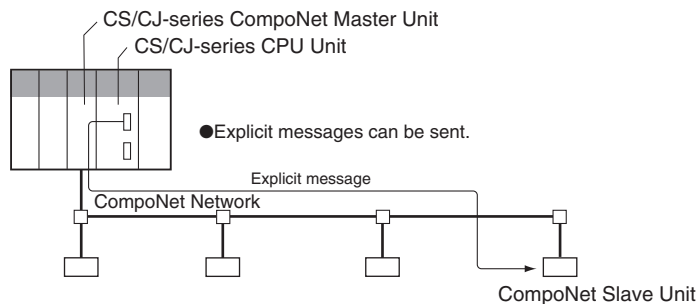

6-4-1 Sending Explicit Messages

When sending an explicit message to a CompoNet Slave Unit, the message is sent to the CompoNet Master Unit using a FINS command (2802) as shown below.

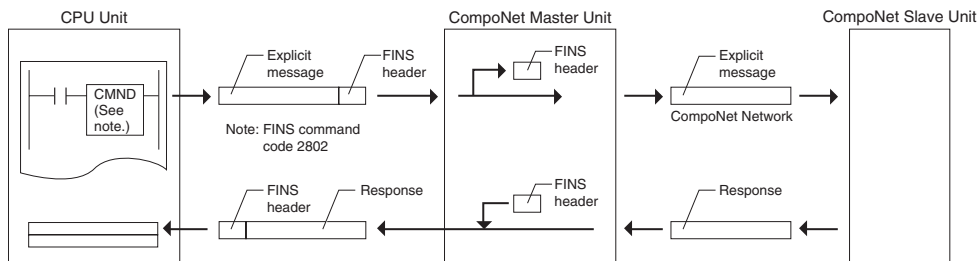

When sending an explicit message, send the FINS command to the Master Unit at the local node, and not to the actual destination (the CompoNet Slave Unit). The actual destination node address is specified in the command data for the explicit message transmission command.

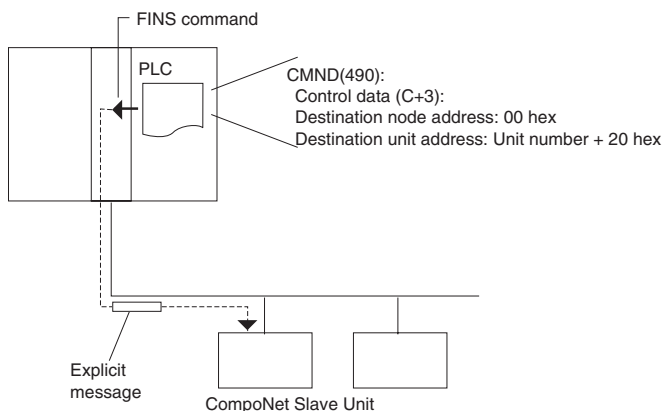

Example

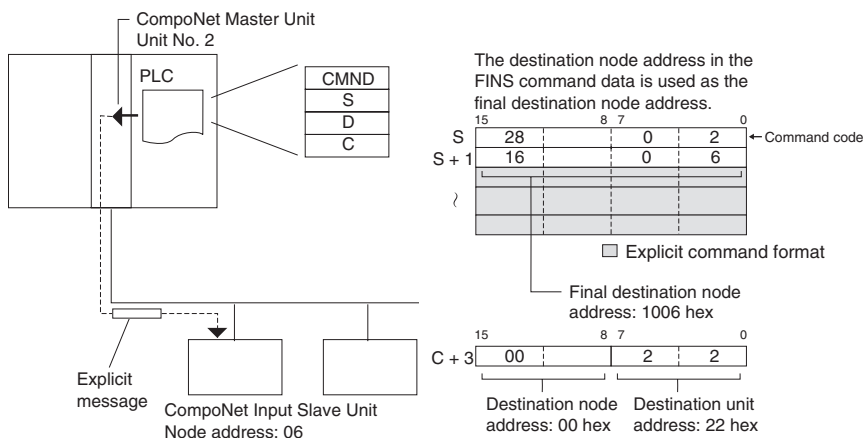

Note Depending on the type of Slave Unit at the destination, a message may not be received. Be sure to set retry processing.

SEND EXPLICIT MESSAGE:
28 02

SEND EXPLICIT MESSAGE sends a CompoNet explicit message to the specified class, and receives a response.

Command Format

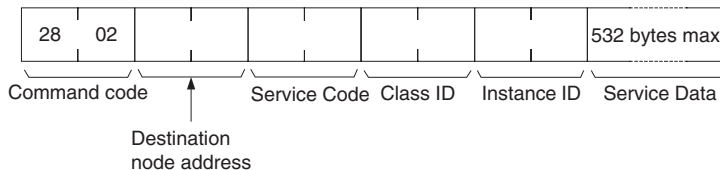

Response Format

• **Normal Response to Explicit Message**

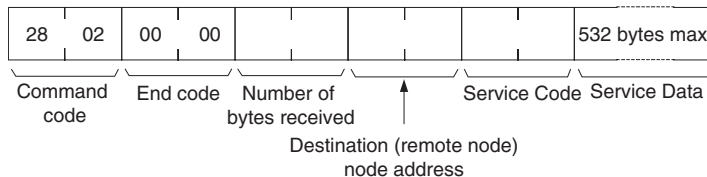

• **Error Response to Explicit Message**

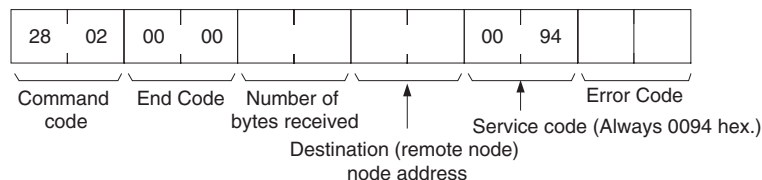

• **Explicit Message Transmission Send Failure or Timeout**

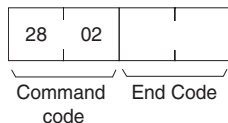

Parameter Details

Destination Node Address (Command)

Specifies the destination node address for the explicit message. With the SEND EXPLICIT MESSAGE command, the Master Unit at the local node is specified in the CMND(490) or IOWR(223) control data and the actual destination node is specified here.

Service Code (Command, Response)

For a command, this parameter specifies the service code defined by the CompoNet Network.

In a normal response, the service code specified in the command is returned with bit 7 turned ON. In an error response, 0094 is returned to indicate an error.

Class ID (Command)

Specifies the destination class ID for the explicit message.

Instance ID (Command)

Specifies the destination instance ID for the explicit message.

Service Data (Command, Response)

For a command, this parameter specifies the data defined by the service code.

The reception data defined by the service code is returned in the response.

Number of Bytes Received (Response)

The number of bytes of data received from the destination (remote node) node address onwards is returned.

Destination (Remote Node) Node Address (Response)

The remote node address of the response source is returned.

Error Code (Response)

The error code defined by the CompoNet Network is returned.

Description

- SEND EXPLICIT MESSAGE sends an explicit message defined by CompoNet to a Slave Unit by another manufacturer and receives a response.
- Unlike other FINS commands, SEND EXPLICIT MESSAGE specifies the CompoNet Master Unit at the local node for the destination in the CMND(490) control code. The actual destination node is specified by the destination node address in the SEND EXPLICIT MESSAGE command. Be sure to set the Master Unit at the local node in the CMND(490) control code. An error will occur if the Master Unit at another node is specified.
- When a CompoNet Master Unit receives an explicit message, it automatically returns a response to the message.

6-4-2 Using CMND(490) to Send Explicit Messages

With CS/CJ-series CompoNet Master Units, explicit messages can be sent using a CMND(490) (DELIVER COMMAND) instruction in the ladder program in the CPU Unit.

The command data for an explicit message is sent with FINS command code 2802 hex attached at the beginning.

An explicit message response is received after FINS command code 2802 hex and the FINS command end code.

[CMND S D C]

S: First command word

D: First response word

C: FINS command end code

Command data is set from the address specified for CMND(490) operand S (first command word) onwards from the upper word to the lower word in the I/O memory in the order of the command format.

Command Format Example

■ In this example, the code to clear an error is written to the CPU Unit.

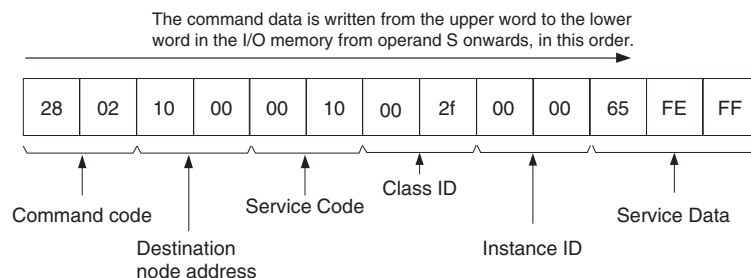

Setting Data from CMND(490) Operand S Onwards

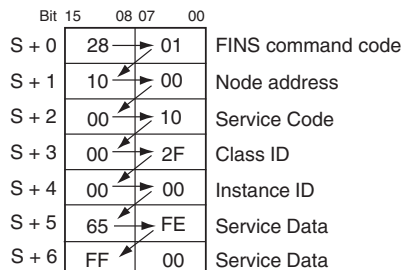

Similarly, from the CMND(490) operand D (first response word) onwards, response data is stored from the upper word to the lower word in the I/O memory in the order of the response format.

Note (1) When the data in the Service Data is in word (2-byte) or double word (4-byte) units, such as for word data or error clearing codes, it is specified from the lower byte to the higher byte as the command format.

For example, to specify word data 1234 hex, specify 34 hex and 12 hex in that order. To specify double word data 12345678 hex, specify 78 hex, 56 hex, 34 hex, and 12 hex in that order. The command formats are as follows:

Command Formats

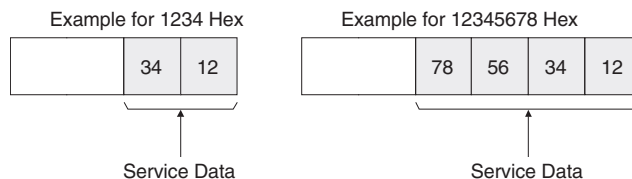

The data from CMND(490) operand S onwards will thus be as follows:

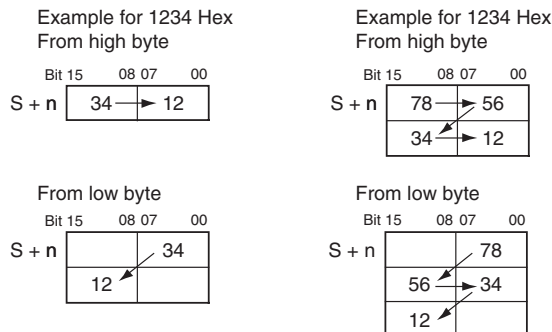

(2) Similarly, when the data in the response format Service Data is returned in word (2-byte) or double word (4-byte) units, it is specified in order from the low byte to the high byte as the command format.

Example Using CMND(490) to Send an Explicit Message

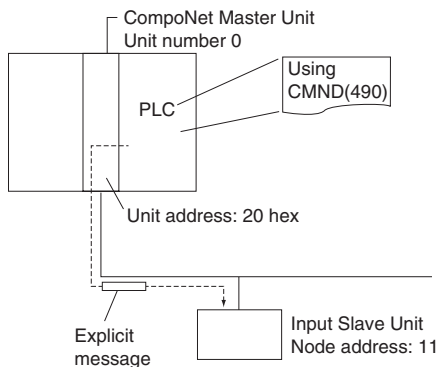

Operation

- Here, the header code (OMRON header code: 002F hex) is read from the Slave Unit.
- Use SEND EXPLICIT MESSAGE (28 02) to read the data.
- The command data is written to D01000 onwards in the CPU Unit of the PLC, and the response data is stored from D02000 onwards.
- If the command results in an error, the completion code is stored in D00006 and the command is sent again.

Command Details

■ [CMND S D C]

S	D01000	+0	: 2802 hex	Command code
		+1	: 100B hex	Input Slave node address: 11
		+2	: 000E hex	Service code 0E hex
		+3	: 0001 hex	Class ID 0001 hex
		+4	: 0001 hex	Instance ID 0001 hex
		+5	: 0100 hex	Attribute ID 01 hex
D	D02000			: First response word
C	D00000	+0	: 000B hex	Number of command data bytes: 11
		+1	: 000C hex	Number of response bytes: 12
		+2	: 0000 hex	Remote (destination) network address: 0
		+3	: 0020 hex	Remote (destination) node address: 0 Remote (destination) unit address: 20 hex
		+4	: 0000 hex	Response: required; Communications port No.: 0; Number of retries: 0 hex
		+5	: 0064 hex	Response monitoring time

Response

D02000	+0	: 2802 hex	
	+1	: 0000 hex	
	+2	: 0004 hex	
	+3	: 100B hex	Response source node address: 11 (0B hex)
	+4	: 008E hex	Normal completion: 8E hex
	+5	: 2F00 hex	The vendor code is stored in order from the upper byte to the lower byte.

Program Example

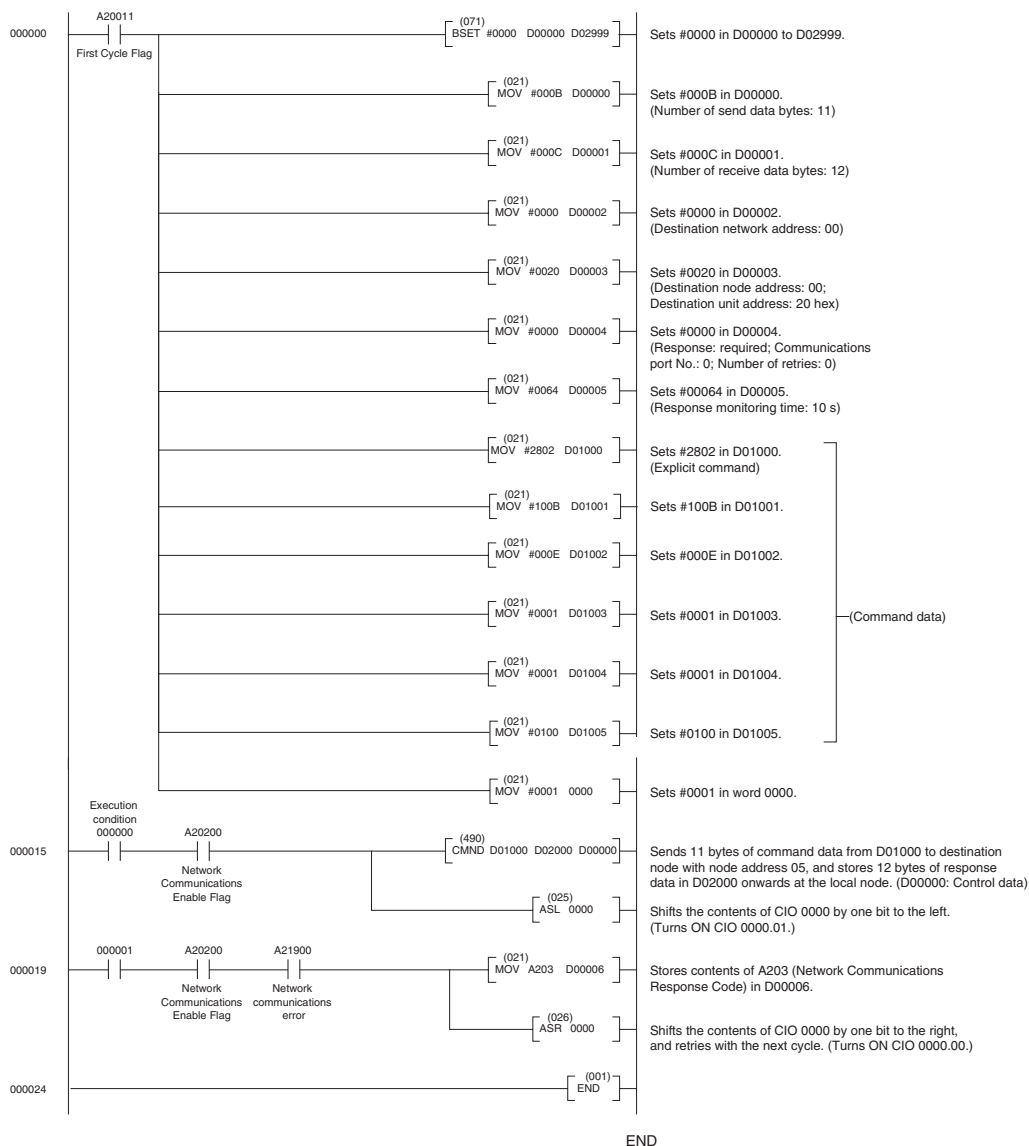

END

SECTION 7

Troubleshooting

This section provides information on dealing with problems that might occur with the Master Unit

- 7-1 Handling Errors 184
 - 7-1-1 CompoNet Master Unit Errors 184
 - 7-1-2 Troubleshooting Sequence When an Error Occurs. 184
- 7-2 Error History Function 190

7-1 Handling Errors

This section describes how to handle CompoNet Network errors that may occur.

7-1-1 CompoNet Master Unit Errors

This section describes the meanings of the LED indicators and seven-segment display when errors occur at a CompoNet Master Unit, and it provides countermeasures for handling the errors.

Meanings of CompoNet Master Unit Indicators and Procedure for Handling Errors

CompoNet Master Units are designed to follow the same basic procedures as CS/CJ-series Special I/O Units for handling errors.

When an error occurs at a Special I/O Unit, the general location of the error is shown by the status of the indicators.

With CompoNet Master Units, in addition to these indicators, a seven-segment display shows the location and content of errors.

7-1-2 Troubleshooting Sequence When an Error Occurs

1. Determine the general location of the error.

Check the pattern in which the indicators are lit to determine whether the error occurred in the PLC or in the network.



2. Determine the details.

Check the seven-segment display and the status area of the CompoNet Master Unit to determine the location and content of the error.



3. Determine the cause of the error.

Consider the onsite conditions in relation to the circumstances of the error, and determine and clear the cause of the error.



4. Take countermeasures.

Check the system status in the *Unit operation after error detection* column, check the required operations in the *Countermeasures* column, and restore system operation to normal.

The CompoNet Master Unit error detection function, operations following error detection, and countermeasures are described on the following pages.

Initialization Errors

MS indicator	NS indicator	7-segment display	Item	Error history (hex)	Probable cause of error	Unit operation after error detection	Countermeasures
⊙ Red	●	H1	Unit number setting error	---	One of the following errors occurred in the unit number setting for the Master Unit. • An illegal unit number was set. • A unit number already being used for another Unit was set.	The Master Unit stops operating and goes into standby mode.	Correct the unit number, and then restart the Master Unit. Either of the following methods can be used to restart the Master Unit: 1) Cycle the power to the PLC. 2) Turn ON the CPU Unit's Special I/O Restart Flag.
⊙ Red	●	H2	The CPU Unit is defective.	---	---		Restart the Master Unit. If the same error occurs again, replace the Master Unit.
○ Red	●	H3	Hardware test error (Unit interface test)	---	An error was detected during the Master Unit interface check.		If the same error occurs even when the Unit is mounted to another CPU Unit, replace the Master Unit.
●	○ Red	H3	Hardware test error (Communications ASIC test)	---	An error was detected during the Master Unit communications ASIC check.		
○ Red	○ Red	H3	Hardware test error (RAM test)	---	An error was detected during the Master Unit RAM check.		
⊙ Red	●	H4	Communications mode setting error	---	An illegal rotary switch setting was detected for the communications mode (i.e., the switch is set to 4, 5, 6, 7, or 9).		Correct the communications mode setting, and then restart the Master Unit.
⊙ Red	●	H6	The CPU Unit is defective.	000F	---	After the error is recorded in the error history, the Master Unit stops operating and goes into standby mode.	Restart the Master Unit. If the same error occurs again, replace the Master Unit.
⊙ Red	●	H7	No I/O table registration.	0006	The Unit is not registered to the CPU Unit's I/O table.		Create the I/O tables.
---	---	H8	Total backup download error	---	A batch backup restoration failed.	The Unit will start with the parameters that are saved internally.	If the error occurs again even after restarting the Unit, set the parameters in the Unit individually.
⊙ Red	---	HA	CPU Unit memory error	0012	An error response to a FINS command (READ ROUTING TABLES) for the CPU Unit was detected.	After the error is recorded in the error history, operation continues without the routing tables.	Restart the Master Unit. If the same error occurs again, replace the Master Unit.
⊙ Red	---	Hb	Event timeout	0011	A timeout was detected for a system setting read request to the CPU Unit.	After the error is recorded in the error history, operation continues while the interface with the CPU Unit is stopped.	
⊙ Red	---	HC	Setting table error	021A	A logical error (such as an out-of-range error) occurred in routing tables read from the CPU Unit at initialization, or a sum error or an error other than a timeout was returned.	After the error is recorded in the error history, operation continues without the routing table.	Correct or delete the routing table.

Indicators

- : Lit
- ⊙ : Flashing
- : Not lit
- : Not applicable

Exception Processing

MS indicator	NS indicator	7-segment display	Item	Error history (hex)	Probable cause of error	Unit operation after error detection	Countermeasures
○ Red	●	Not lit	Unit-related error	0601	Special I/O Unit error	After the error is registered in the error history, WDT refreshing is stopped and the Master Unit completely stops.	There may be some noise interference occurring. Eliminate the source of the noise and then turn ON the power to the PLC again.
○ Red	●	Not lit	Unit WDT error	---	There was a WDT timeout for the Unit.	The Master Unit completely stops.	

Indicators

- : Lit
- ⊙ : Flashing
- : Not lit
- : Not applicable

Errors in PLC Monitoring

MS indicator	NS indicator	7-segment display	Item	Error history (hex)	Probable cause of error	Unit operation after error detection	Countermeasures
---	---	---	Fatal CPU Unit error	---	The CPU Unit Fatal Error Bit is ON for the Unit status information in the cyclic area.	System operation continues and the I/O cycle is stopped.	Check and clear the error in the CPU Unit. When the Fatal Error Bit turns OFF, operation will automatically recover.
---	---	---	Load OFF	---	The Load OFF Bit is ON in the Unit status information in the cyclic area.	System operation continues and the I/O cycle is stopped. Load OFF Bit monitoring continues. After recovery, normal operation is restored.	Check the situation at the CPU Unit. When the Load OFF Bit turns OFF, operation will automatically recover. Note This occurrence is not an error.
⊙ Red	---	H9	Bus error	000E	An error occurred in the bus for exchanging data with the CPU Unit.	<ul style="list-style-type: none"> • Cyclic operations are stopped. • The communications cycle is stopped. 	Restart the PLC by cycling the power.
⊙ Red	---	HF	CPU Unit WDT error	0001	An error occurred at the CPU Unit, and CPU Unit operations stopped.	The error is registered in the error history. System operation continues, but the communications cycle is stopped.	Clear the error in the CPU Unit, and then restart the Master Unit.
●	●	Not lit	Power failure	---	The CPU Unit power supply is down.	System operation is completely stopped by a hardware reset.	Clear the cause of the failure and turn ON the power again.
⊙ Red	---	HE	CPU Unit monitoring error	0002	Service from the CPU Unit is irregular. The monitoring time is acquired at initialization. Normally monitoring is for 11 s.	<ul style="list-style-type: none"> • The I/O cycle is stopped. • Cyclic operations are stopped. • The final data is provided to an output Slave Unit. There is a possibility of recovery from this error, restoring normal operations.	Check the CPU Unit operating environment.







Indicators

- : Lit
- ⊙ : Flashing
- : Not lit
- : Not applicable

Errors in Remote I/O Communications

The following indicator patterns show that an error related to the CompoNet Network has occurred.

Errors can basically be identified by the NS indicator flashing red and the seven-segment display showing d*.

MS indicator	NS indicator	7-segment display	Item	Error history (hex)	Probable cause of error	Unit operation after error detection	Countermeasures
---	 Red	d9 ↓ yy ↓ zzz	Communications error	0374	A system disconnection was detected.	System operations continue. Each detected disconnection is registered in the error history. Participation of the disconnected Slave Unit is awaited. When there is no longer any cause of an error, normal operation is restored. (The NS indicator lights green.)	Either of the following may be the cause of the error. 1) Communications had to be continually retried for the applicable Slave Unit due to noise, until the specified number of retries was exceeded. 2) Responses to communications from the Master Unit are not possible because of a malfunction, line disconnection, or communications power supply interruption at the Slave Unit itself. Inspect the Slave Unit where the disconnection was detected, and remove the cause of the error. There is no need to restart the Master Unit.
---	 Red	d0 ↓ yy ↓ zzz	Address duplication error	0376	An address duplication error was detected for a Slave Unit attempting to participate.	The duplication error is registered in the error history. All system operations continue.	A Slave Unit or Repeater Unit in the same network is set for the same node. Use the following procedure: 1) Turn OFF the power to the Master Unit and the Slave Unit. 2) Change the duplicate node number to a new value. 3) Turn the power back ON to the Master Unit and the Slave Unit.
---	 Red	E5	Illegal configuration error	0378	It was detected that the Slave Units and Repeater Units requesting to participate in the network exceeded the permitted number of Repeater Unit segments (two).	Subsequent Slave Unit participation is prohibited from the point where it is detected that the permitted number of Repeater Unit segments has been exceeded in the participation processing. Other system operations continue. The error is registered in the error history. After normal status is restored, the Unit recovers by being restarted.	The maximum number of Repeater Unit segments is registered to two in the Master Unit and cannot be changed. This error thus indicates that there are three or more Repeater Unit segments. Correct the wiring and restart the Master Unit.
---	 Red	d5 ↓ yy ↓ zzz	Verification error (non-existent Slave Unit)	0370	It was detected that a Slave Unit registered in the Registration Table is not participating within a fixed time after power is turned ON to the Master Unit. The monitoring time is set using CompoNet Support Software.	The error is registered in the error history. System operations all continue, and remote I/O operations start. Participation of the Slave Unit where the error occurred continues to be monitored. When Slave Unit participation is completed, normal status is restored. (The NS indicator lights green.)	If the error is not cleared, check the Slave Unit that is not participating.
---	 Red	d6 ↓ yy	Verification error (unregistered Slave Unit)	0372	Participation of an unregistered Slave Unit was detected.	The error is registered in the error history. All other system operations continue, without the participation of the unregistered Slave Unit. Recovery is attained by restoring normal status and restarting the Unit.	Check and correct the status of the unregistered Slave Unit, and then restart the Master Unit.
---	 Red	A0	Communications have stopped due to a communications error.	0375	A communications error was detected while communications were set to be stopped when a communications error occurred.	The error is registered in the error history. System operations continue. Remote I/O communications with the Slave Units stop, and communications with the CPU Unit continue. There is no automatic recovery even after the cause of the error is removed. The Unit must be restarted to recover.	Check and eliminate the cause of the error, and then restart the Master Unit.

Indicators

: Lit

⊙: Flashing

●: Not lit

---: Not applicable

yy: Indicates the Slave Unit type, as shown below.

yy	Actual display	Slave Unit type
i		Input (including inputs and outputs together)
o		Output
bi		Bit input
bo		Bit output
r		Repeater Unit

zzz: Node address where the error occurred (2 digits decimal) (Note: The 100s digit is displayed with a dot.)

Errors in Memory Access Processing

The following indicator patterns show that an error has occurred in the CPU Unit where the Master Unit is mounted.

MS indicator	NS indicator	7-segment display	Item	Error history (hex)	Probable cause of error	Unit operation after error detection	Countermeasures
⊙ Red	---	E4	Software setting table logic error	021A	1) The mode is the Software Setting Mode (Mode 8) even though the Software Setting Table is disabled. 2) The Software Setting Table is corrupted.	The error is registered in the error history. Data and message exchanges with the CPU Unit are executed without starting remote I/O communications.	1) Restart the Master Unit in Mode 8. 2) Using CompoNet Support Software, reset the Software Setting Table.
⊙ Red	---	E6	Network parameters logic error	021A	The Network Parameters Table is corrupted.		Using CompoNet Support Software, reset the network parameters.
⊙ Red	---	E7	Slave Unit parameters logic error	021A	The Slave Unit Parameters Table is corrupted.		Using CompoNet Support Software, reset the Slave Unit parameters.
⊙ Red	---	E8	Registration Table logic error	021A	1) The registration settings (REGS) are enabled even though the Registration Table is disabled. 2) The Registration Table is corrupted.		Using CompoNet Support Software, reset the Registration Table.
⊙ Red	---	E9	Memory access error	0602	One of the following errors occurred when the non-volatile memory in the Unit was accessed: 1) Not all 64 records could be used during initialization or when registering an error in the error history. 2) An error history reading or writing error 3) A network parameters reading or writing failure during initialization 4) An identity information reading failure during initialization 5) A Registration Table information reading or writing failure during initialization 6) A Software Setting Table information reading or writing failure during initialization	For 1) and 2), access to EEPROM stops from RAM error history registration onwards. All other normal operations continue. (Registering the error history to RAM continues.) For 3), 5), and 6) (reading), other operations continue without starting the communications cycle. For 3), 5), and 6) (writing), further accessing of EEPROM is stopped. Aside from these, normal operations continue. For 4), normal operations are executed.	Restart the Master Unit. If the same error occurs again, replace the Master Unit.

Indicators

○: Lit

⊙: Flashing

● : Not lit
 ---: Not applicable

Slave Unit Errors

The following indicator patterns show that a Slave Unit has detected an error.

MS indicator	NS indicator	Item	Probable cause of error	Unit operation after error detection	Countermeasures
●	---	No power supply input	The specified power supply voltage is not being supplied from the communications power supply.	Slave Unit operation stops.	Remove the cause of the error, and turn ON the power again. If the Slave Unit still does not operate normally when the power supply voltage is being supplied in the specified range, then replace the Slave Unit.
○ Green	◎ Red	Communications error	Remote I/O communications with the Master Unit timed out and stopped after a connection had been established.	Slave Unit operation continues. Output Units control output functions according to the communications error output setting function for when errors occur.	Any of the following may be the cause of the communications error. 1) Operation was stopped by a PLC System error, including the Master Unit. Check the PLC System status and clear the error. There is no need to restart the Slave Unit. 2) Communications with the Master Unit are impossible because of a problem such as a disconnected line or a malfunction. Check the cables, terminals, and Repeater Units. Clear the error, and then turn the communications power supply back ON again. 3) Communications with the applicable Slave Unit had to continue to be retried because of noise. The number of retries exceeded the specified value, so the Master Unit stopped communications. Check for noise interference around the affected Slave Unit. Aside from 1) above, there is no need to restart the Master Unit.
○ Green	○ Red	Address duplication error	A Slave Unit with the same node address exists on the network.	Slave Unit operation stops.	Check and correct the Slave Unit's node numbers, and then perform the following procedure: 1) Turn OFF the communications power supply for the Master Unit and the Slave Unit. 2) Turn the communications power supply back ON again.
○ Red	---	Unit error	An error occurred at the Slave Unit itself for one of the following reasons. 1) The Slave Unit failed to write to internal memory (EEPROM). 2) The Slave Unit failed to read internal memory (EEPROM).	Slave Unit operation stops. For Output Units, outputs stop.	To eliminate the first possibility, check the set value for the Slave Unit's node address. Then restart the Slave Unit (i.e., turn the communications power supply OFF and back ON again). If the same error occurs again, replace the Slave Unit.

Indicators

○ : Lit
 ◎ : Flashing
 ● : Not lit
 ---: Not applicable

Repeater Unit Errors The following indicator patterns show that a Repeater Unit has detected an error.

MS indicator	NS indicator	Item	Probable cause of error	Unit operation after error detection	Countermeasures
● Not lit	---	No power supply	The specified power supply voltage is not being supplied from the communications power supply.	Repeater Unit operation stops.	Remove the cause of the error, and turn ON the power again. If the Repeater Unit still does not operate normally when the power supply voltage is being supplied in the specified range, then replace the Repeater Unit.
○ Green	◎ Red	Communications error	Remote I/O communications with the Master Unit timed out and stopped after a connection had been established.	Repeater Unit operation continues.	Any of the following may be the cause of the communications error. Check and remove the cause of the error. 1) Operation was stopped by a PLC System error, including the Master Unit. Check the PLC System status and clear the error. There is no need to restart the Repeater Unit. 2) Communications with the Master Unit are impossible because of a problem such as a disconnected line or a malfunction. Check the cables, terminals, and Repeater Units. Clear the error, and then turn the communications power supply back ON again. 3) Communications with the applicable Unit had to continue to be retried because of noise. The number of retries exceeded the specified value, so the Master Unit stopped communications. Check for noise interference around the affected Unit. Aside from 1) above, there is no need to restart the Master Unit.
○ Green	○ Red	Address duplication error	A Repeater Unit with the same node address exists on the network.	Repeater Unit operation stops.	Check and correct the Repeater Unit's node number, and then perform the following procedure: 1) Turn OFF the communications power supply for the Master Unit and the Repeater Unit. 2) Turn the communications power supply back ON again.
○ Red	---	Unit error	An error occurred at the Repeater Unit itself for one of the following reasons. 1) The Repeater Unit failed to write to internal memory (EEPROM). 2) The Repeater Unit failed to read internal memory (EEPROM).	Repeater Unit operation stops.	To eliminate the first possibility, check the set value for the Repeater Unit's node address. Then restart the Repeater Unit (i.e., turn the communications power supply OFF and back ON again). If the same error occurs again, replace the Repeater Unit.

Indicators

- : Lit
- ◎: Flashing
- : Not lit
- : Not applicable

7-2 Error History Function

The error history registers errors detected by the CompoNet Master Unit, along with the times at which they occur. The recorded results can be read and cleared by FINS commands to the CompoNet Master Unit. They can also be monitored using CompoNet Support Software.

Error History Table

Error History Table

Each time an error occurs, one record (up to a maximum of 64 records) is registered in the Error History Table in the CompoNet Master Unit's internal RAM. Once the maximum number of records (64) has been registered in the Error History Table, the oldest record is deleted in order with each new record that is registered.

The following information is stored in the Error History Table.

- Error codes

- Detail codes
- The times at which errors occurred (using the CPU Unit's time data)

Error History Save Area

When an error is detected, the contents of the error and the time at which it occurred are registered as an error history in the Unit's internal RAM. Serious errors are registered not only in RAM but also in EEPROM. The error history registered in EEPROM is saved during a power interruption or when the Unit is restarted. When the CompoNet Master Unit is started, the error history in EEPROM is copied to RAM.

When the contents of the error history are read by a FINS command or CompoNet Support Software, it is the error history saved on RAM that is read. When the error history is cleared (either by a FINS command or CompoNet Support Software), however, it is cleared from both RAM and EEPROM.

Reading or Clearing Error History Tables

Use FINS commands to the CompoNet Master Unit to read or clear the Error History Table. Use the CompoNet Master Unit as the destination address for FINS commands.

CompoNet Master Unit address: 20 hex + unit number

For instructions on using FINS commands, refer to the *CS/CJ-series PLC Communications Command Reference Manual* (Cat. No. W342).

For details on FINS commands for CompoNet Master Units, refer to *Appendix A*.

Note The CPU Unit's time information is read and used by the CompoNet Master Unit. If this time information cannot be read from the CPU Unit, the error history time information will be shown as all zeros. In addition, for CS/CJ-series PLCs, the time setting for the CPU Unit's built-in clock must be reset when the power is turned ON after replacing the battery. If the time is not reset, correct time information will not be registered. When the error history is read, the time information will be unreliable.

Error Code and Detailed Information Tables

Error code (hex)	Error contents	Detailed information		EEP ROM
		First byte	Second byte	
0001	CPU Unit WDT error	00 hex	00 hex	○
0002	CPU Unit service monitoring error (Service from the CPU Unit is irregular.)	Monitoring time (ms)		○
0006	Other CPU Unit errors	Bit 14: Unit number duplication Bit 11: No applicable Unit in Registration Table All other bits are reserved.		○
000F	CPU Unit initialization error	00 hex	00 hex	○
0011	Event timeout	MRC	SRC	○
0012	CPU Unit memory error	01 hex: Read error 02 hex: Write error	03 hex: Routing Table	○
0101	Transmission is not possible because local node is not participating in the network.			×
0103	Transmission is not possible because of too many resends.	Command Bit 15: OFF		×
0106	Transmission is not possible because of an address duplication error.	Bits 14 to 8: SNA Bits 7 to 0: SA1		×

Error code (hex)	Error contents	Detailed information		EEP ROM
		First byte	Second byte	
0107	Transmission is not possible because remote node is not participating in the network.	Response Bit 15: ON		×
0108	Transmission is not possible because there is no Unit corresponding to the unit number.	Bits 14 to 8: DNA Bits 7 to 0: DA1		×
0109	Transmission is not possible because the remote node is busy.			×
010B	Transmission is not possible because of a PLC error.			×
010D	Transmission is not possible because no destination address is set in the routing tables.			×
010E	Transmission is not possible because the routing tables are not registered.			×
010F	Transmission is not possible because of a routing table error.	Command Bit 15: OFF		×
0110	Transmission is not possible because of too many relays.	Bits 14 to 8: SNA Bits 7 to 0: SA1		×
0111	Transmission is not possible because the command exceeds the maximum command length.	Response Bit 15: ON		×
0112	Transmission is not possible because of a header error.	Bits 14 to 8: DNA Bits 7 to 0: DA1		×
0117	Packet was discarded because the internal reception buffer was full.			×
0118	Illegal packet discarded			×
0120	Unexpected routing error			×
0122	Packet was discarded because it could not be serviced in the current mode.			×
0123	Packet was discarded because the internal buffer was full.			×
0124	Routing is not possible because the maximum frame length was exceeded.			×
0125	Packet was discarded because of a response timeout.			×
0300	Packet was discarded because of a parameter error.			×
021A	Setting table logic error	00 hex	01 hex: Network parameters 02 hex: Software Setting Table 03 hex: Routing Table 04 hex: System Setup 0A hex: Registration Table	○
0347	I/O refresh error	00 hex	00 hex	×
0370	Verification error (non-existent Slave Unit)	00	00	×
0372	Verification error (unregistered Slave Unit)	10 hex: Word Input Slave Unit, Word I/O Slave Unit 20 hex: Word Output Slave Unit 40 hex: Bit Input Slave Unit, Bit I/O Slave Unit 50 hex: Bit Output Slave Unit	Node address (hex)	×

Error code (hex)	Error contents	Detailed information		EEP ROM
		First byte	Second byte	
0374	Communications error	10 hex: Word Input Slave Unit, Word I/O Slave Unit 20 hex: Word Output Slave Unit 40 hex: Bit Input Slave Unit, Bit I/O Slave Unit 50 hex: Bit Output Slave Unit 70 hex: Repeater Unit	Node address (hex)	×
0375	Communications have stopped due to a communications error. [Cause] A communications error occurred while communications were set to be stopped.	10 hex: Word Input Slave Unit, Word I/O Slave Unit 20 hex: Word Output Slave Unit 40 hex: Bit Input Slave Unit, Bit I/O Slave Unit 50 hex: Bit Output Slave Unit	Node address (hex)	○
0376	Address duplication error	10 hex: Word Input Slave Unit, Word I/O Slave Unit 20 hex: Word Output Slave Unit 40 hex: Bit Input Slave Unit, Bit I/O Slave Unit 50 hex: Bit Output Slave Unit 70 hex: Repeater Unit	Node address (hex)	×
0378	Illegal Repeater Unit/configuration error	10 hex: Word Input Slave Unit, Word I/O Slave Unit 20 hex: Word Output Slave Unit 40 hex: Bit Input Slave Unit, Bit I/O Slave Unit 50 hex: Bit Output Slave Unit 70 hex: Repeater Unit	Node address (hex)	×
0601	Illegal interrupt	00	00	○
0602	Special I/O Unit memory error	01 hex: Read error 02 hex: Write error	01 hex: Network parameters 02 hex: Software Setting Table 04 hex: Slave Unit parameters 06 hex: Error history 09 hex: Identity information 0A hex: Registration Table	○ (Error history only: x)

Appendix A

FINS Commands Addressed to CompoNet Master Units and Responses

Command Codes

Commands Addressed to CompoNet Master Units

Command	Command code
START I/O COMMUNICATIONS	0401
RESET	0403
READ CONTROLLER INFORMATION	0501
ECHOBACK TEST	0801
READ ERROR LOG	2102
CLEAR ERROR LOG	2103

CompoNet Explicit Message Command

Command type	Command code
SEND EXPLICIT MESSAGE	2802

START I/O COMMUNICATIONS	0401
---------------------------------	-------------

Starts I/O communications for the CompoNet Master Unit.

Command Format

MRC 04	SRC 01
1B	1B

Response Format

MRC 04	SRC 01	MRES	SRES
1B	1B	1B	1B

End Codes (MRES/SRES)

End code (hex)	Contents
0000	Normal completion
1001	The maximum permissible command length was exceeded.
2605	I/O communications are already being executed.

Description

START I/O COMMUNICATIONS starts I/O communications for the CompoNet Master Unit. It can be used in RUN, MONITOR, or PROGRAM mode. It can be executed only while I/O communications are stopped. (It cannot be executed during I/O communications or while the communications cycle is stopped.)

RESET	0403
--------------	-------------

Resets (restarts) the CompoNet Master Unit.
 A parameter can be added to restart at a specified baud rate.

Command Format for Resetting

MRC 04	SRC 03
1B	1B

Command Format for Resetting at a Specified Baud Rate

MRC 04	SRC 03	FLAG XX
1B	1B	1B

Response Format

MRC 04	SRC 03	MRES	SRES
1B	1B	1B	1B

Note No response is returned for a normal completion. A response is returned only when an error occurs.

End Codes (MRES/SRES)

End code (hex)	Contents
1001	The maximum permissible command length was exceeded.
1004	There is an error in the command format.
250F	A memory error occurred.

Parameter Details

FLAG: Stores a value specifying the desired baud rate.

- 01 hex: Reset at 93.75 k.
- 02 hex: Reset at 1.5 M.
- 03 hex: Reset at 3 M.
- 04 hex: Reset at 4 M.
- 00/FF hex: Reset at baud rate set on DIP switch.

Description

RESET resets the CompoNet Master Unit.
 No response is returned for a normal completion. A response is returned only when an error occurs.
 This command is used to restore operation after resetting the Master Unit when a communications error has occurred at a Slave Unit during I/O communications.

READ CONTROLLER INFORMATION	0501
------------------------------------	-------------

Reads CompoNet Master Unit information.

Command Format

MRC	SRC
05	01
1B	1B

Response Format

MRC	SRC	MRES	SRES	Model	Version	Mode No.	DIP Switch
05	01						
1B	1B	1B	1B	20B	20B	1B	1B

End Codes (MRES/SRES)

End code (hex)	Contents
0000	Normal completion
1001	The maximum permissible command length was exceeded.

Parameter Details

Model (Response)

The CompoNet Master Unit model number is returned in up to 20 bytes of ASCII.
The unused portion of the 20 bytes is padded with spaces (20 hex).

CJ1W-CRM21□□□□□□□□□□ (□: Space)

or

CS1W-CRM21□□□□□□□□□□ (□: Space)

Version (Response)

V1.00□□□□□□□□□□□□□□□□ (□: Space)

Mode No.

The mode number set on the mode setting switch is returned.
0x00 to 0x09

DIP Switch

The DIP switch setting for five pins are returned.

D7	D6	D5	D4	D3	D2	D1	D0
Always 0.	Always 0.	Always 0.	Always 0.	REGS	ESTP	DR-H	DR-L

0: OFF, 1: ON

ECHOBACK TEST	0801
---------------	------

Executes an echoback test between specified nodes.

Command Format

MRC 08	SRC 01	Test data
1B	1B	1 to 538B

Response Format

MRC 08	SRC 01	MRES	SRES	Test data
1B	1B	1B	1B	1 to 538B (Data specified in command)

End Codes (MRES/SRES)

End code (hex)	Contents
0000	Normal completion
1001	The maximum permissible command length was exceeded.
1002	The command length is less than the minimum command length. (There is no test data.)

Parameter Details

Test Data (Command)

The destination address is the address specified by the FINS header.

Test Data (Response)

The test data sent in the command is returned from the remote node just as it is. If the test data contents are different, an error occurred.

READ ERROR LOG	2102
-----------------------	-------------

Reads the CompoNet Master Unit error history.

Command Format

MRC 21	SRC 02	First record to read	Number of records to read
1B	1B	2B	2B

Response Format

MRC 21	SRC 02	MRES	SRES	Max. number of records	Number of records stored	Number of records read	Error history records
1B	1B	1B	1B	2B	2B	2B	10B

End Codes (MRES/SRES)

End code (hex)	Contents
0000	Normal completion
1001	The maximum permissible command length was exceeded.
1002	The command length is less than the minimum command length.
1103	An error occurred because an out-of-range address was specified. The beginning record number read is greater than the number of records currently stored.
110B	The maximum response length was exceeded. The response exceeded the maximum frame length.
110C	Another error occurred. The number of read records is 0.

- Note**
- (1) If there is insufficient error history data for the number of records to read, all the records currently stored are returned and a normal completion (0000 hex) response is returned.
 - (2) If 0000 hex is specified for the beginning record number read, the response will be taken as normal completion (0000 hex) even if the number of records stored is 0000 hex. A response will be returned containing the maximum number of records, the number of records stored, and the number of records read.

Parameter Details

First Record to Read (Command)

Specify the first record number read in hexadecimal.

With the top record number (the oldest record) taken as 0000 hex, the first record number read is specified from 0000 to 003F (0 to 63 decimal).

Number of Records to Read (Command)

Specify in hexadecimal the number of records to read. Any number from 0001 to 0035 (1 to 53 decimal) can be specified.

(Error history records beyond 53 must be read separately, with the First record to read set to 0035 hex.)

Maximum Number of Records (Response)

The maximum number of error history records that can be stored is returned in hexadecimal.

With CompoNet Master Units, this number is always 0040 hex (64 decimal).

Number of Records Stored (Response)

The number of error history records stored when the command is executed is returned in hexadecimal.

Number of Records Read (Response)

The number of records actually read is returned in hexadecimal.

Error History Records (Response)

1st byte								10th byte
Error code	Detailed information	Minutes	Seconds	Day of month	Hour	Year	Mo.	
2B	2B	1B	1B	1B	1B	1B	1B	

- Error Code and Detailed Information
For details, refer to the list of error history codes.
- Minutes, Seconds, Day of month, Hour, Year, and Month
The date and time when the error occurred are displayed in BCD.

CLEAR ERROR LOG	2103
------------------------	-------------

Clears the CompoNet Master Unit error history.

Command Format

MRC	SRC
21	03
1B	1B

Response Format

MRC	SRC	MRES	SRES
21	03		
1B	1B	1B	1B

End Codes (MRES/SRES)

End code (hex)	Contents
0000	Normal completion
1001	The maximum permissible command length was exceeded.

SEND EXPLICIT MESSAGE	2802
------------------------------	-------------

Sends an explicit message.

Command Format

MRC	SRC	Destination (remote node address)	Service code	Class ID	Instance ID	Service data
28	02					
1B	1B	2B	2B	2B	2B	To Slave Unit: 532B To Master Unit: 532B

Response Format

- Normal Response to Explicit Message

MRC	SRC	End code	No. of bytes received	Destination (remote node address)	Service code	Service data
28	02	0000				
1B	1B	2B	2B	2B	2B	To Slave Unit: 532B To Master Unit: 532B

- Error Response to Explicit Message

MRC	SRC	End code	No. of bytes received	Destination (remote node address)	Service code	Error code
28	02	0000			0094	
1B	1B	2B	2B	2B	2B	2B

- Explicit Message Send Failure or Timeout

MRC	SRC	End code
28	02	
1B	1B	2B

End Codes (MRES/SRES)

End code (hex)	Contents
0000	Normal completion
0101	The network for the local node is not operating.
0201	The network for the remote node is not operating.
0204	The message cannot be sent because the remote node is busy.
0205	Monitoring time expired with no response from the remote node.
1001	The maximum permissible command length was exceeded.
1002	The command length is less than the minimum command length.
1004	The command format is not suitable.
1005	There is a header error. (The destination address setting is illegal.)
110B	The response exceeded the maximum response length.
2211	The Unit is busy. (The memory required for internal transmission processing cannot be reserved.)
2609	The required settings have not been made.

Error Codes

End code (hex)	Contents
0x02FF	A required resource was not available.
0x08FF	A requested service was not supported.
0x09FF	Attribute data is illegal.
0x0BFF	The specified object was already in the requested state.
0x0CFF	The requested service cannot be executed for the specified object.
0x0EFF	An unchangeable attribute was specified.
0x10FF	The requested service cannot be executed for the specified device.
0x11FF	The response data is too long to be processed.
0x13FF	There is insufficient data provided for processing.
0x14FF	The attribute is undefined.
0x15FF	Invalid data is included.
0x16FF	The object is not implemented.
0x19FF	The save operation failed.
0x1F□□	A header error occurred. (Detailed error information is stored in □□.)
0x20FF	There is an error in the parameters.
0x28FF	A class, instance, or attribute that is not implemented was specified for the member ID of the requested service.

Parameter Details

Destination (Remote Node) Node Address

Provides the node address of a remote device.

D15	D14	D13	D12	D11	D10	D9	D8	D7	D6	D5	D4	D3	D2	D1	D0
Classification				0	0	0	0	Master Unit: Always 0. Word Slave Unit: 0 to 0x3F Bit Slave Unit: 0 to 0x7F Repeater Unit: 0 to 0x3F							
0x0: Master Unit															
0x1: Normal Input or I/O Unit															
0x2: Word Output Unit															
0x4: Bit Input or I/O Unit															
0x5: Bit Output Unit															
0x7: Repeater Unit															

Service Code

Specifies the service code defined for the explicit message.

Class ID

Specifies the remote class ID requesting the explicit message.

Instance ID

Specifies the remote instance ID requesting the explicit message.

Service Data

Specifies the data defined by the service code.

The effective number of bytes is 00 to 216 hex (534 bytes).

Number of Bytes Received

The number of bytes of data received from the destination (remote node) node address onwards is returned.

Destination (Remote Node) Node Address (Response)

The Slave Unit node address returned in the explicit message response is returned.

Error Code

The error code defined by CompoNet is returned.

Index

A

addresses
 Slave Units, 121
Analog I/O Slave Units, 14, 15
applications
 precautions, xviii
automatic baud rate detection, 7

B

BDH, 51
BDL, 51
Bit Slave Units, 16
 data allocation, 141
bit-level distribution, 5
branch lines, 4
branches, 4
 multidrop connections, 4
 T-branch connections, 4

C

cables
 cable types, 53
 connecting cables, 74
 DCA4-4F10 Standard Flat Cable, 54
 DCA5-4F10 Sheathed Flat Cable, 54
 extending the cable length, 60
 selecting cable types, 55
 VCTF 2-conductor cable, 53
CMND instruction, 169, 172, 174, 178, 180
communications
 connector, 47
 errors, 120
 stopping communications, 6
 indicators, 43
 mode number, 12
 power supply, 4, 63, 95, 97
 power supply connector, 47
 power supply specifications, 98
 power supply wiring examples, 101
communications cables, xx
communications errors
 input data zero clear mode, 7
component names and functions, 41
CompoNet networks, 2
 features, 5

 connection methods, 56
 Flat Cable, 56
 VCTF 2-conductor Cable, 56
connectors
 Branch Line Pressure-welded Connectors, 20
 Trunk Line Pressure-welded Connectors, 19
crimp terminals, xix
current consumption, 99

D

Digital I/O Slave Units, 14, 15
dimensions, 48
DIN track, 72
DIP switch
 baud rate setting, 46
 communications error communications stop mode setting, 46
 registration table enable, 46

E

EC Directives, xx
e-CON, 16, 17, 111
electromagnetic fields, xviii
EMC Directives, xx
EMI Standard, xx
EMS Standard, xx
error history, 190
 error code, 191
 error history table, 190
 save area, 191
errors
 exception processing, 186
 initialization errors, 185
 memory access processing, 188
 PLC monitoring, 186
 remote I/O communications, 187
 Repeater Units, 190
 Slave Units, 189
explicit message communications, 169
explicit messages, sending, 176

F

FALS instruction, xvii
FINS command list, 171

FINS commands and responses

command codes, 195

overview, 170

FINS message communications, 168, 172

flags

Communications Error Flags, 123, 149

Communications Flags, 173

Participation Flags, 123, 149

G

ground

precautions, xix

H

high-speed multi-point processing, 5

I

I/O communications manual startup mode, 6

I/O power supply, 95, 109

I/O response time, 156

maximum I/O response time, 157

minimum I/O response time, 163

illegal configuration error, 129

installation, 66

location, xvii

L

locking devices

precautions, xix

Low Voltage Directive, xx

M

Master Units, 3, 14, 57

errors, 184

specifications, 40

message communications

explicit message communications, 169

FINS message communications, 168

overview, 168

specifications, 169

message monitoring timer, 169

multidrop connections, 60

Multi-power Supply Slave Units, 96

Multi-wiring Connector, 81

N

network communications completion code, 173

Network Power Supply Slave Units, 97

node address types, 135

noise, xviii

O

online editing, xvii

operating environment precautions, xvii

outputs

precautions, xvii

P

peripheral devices

communications cables, 18

connectors, 19

Sheathed Flat Cable, 67

special tools, 22

Standard Flat Cable, 67

Terminal Block Adapter, 23

Terminating Resistance, 23

pin terminal

conductor length, 114

power supply, xviii

precautions, xviii, xix

wiring, 95

precautions, xv

applications, xviii

general, xvi

operating environment, xvii

safety, xvi

Pressure-welded Connectors, 84

programless communications, 5

R

radiated emission, xx

radioactivity, xviii

Registered Slave Participation Monitoring Time, 128

Registered Slave Participation Standby Mode, 128

registration tables, 6, 125

creating, 127

remote I/O communications, 120
Repeater Units, 3, 5, 18, 58
replacing parts
 precautions, xix
replacing Units
 precautions, xix

Word Slave Units, 15
 data allocation, 137

S

safety precautions, xvi
screw-less clamp terminal blocks, 114
sensor connectors
 industrial standard connectors, 111
seven-segment display, 7, 43
short-circuits
 precautions, xviii
signals
 precautions, xviii
Slave Units, 3, 14, 58
 address duplication error, 128
 allocation, 129
Smart Slave Unit Functions, 6
static electricity precautions, xviii
status, 146
status area allocation, 146
switch settings, 45
 MODE switch, 45
 unit number switches, 45
system configuration patterns, 4

T

T-branches, 58
Terminal Block Adapter, 77, 79
terminating resistance, 3, 61, 82
tools, 84
trunk lines, 4

U

unit number allocations, 133

W

wiring
 trunk line-branch line formation, 50, 51
 unrestricted wiring formation, 50

Revision History

A manual revision code appears as a suffix to the catalog number on the front cover of the manual.

Cat. No. W456-E1-01

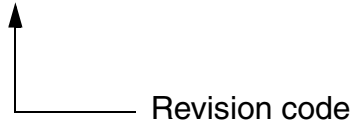

The following table outlines the changes made to the manual during each revision. Page numbers refer to the previous version.

Revision code	Date	Revised content
01	September 2006	Original production

Revision History

OMRON Corporation

Control Devices Division H.Q.

Shiokoji Horikawa, Shimogyo-ku,
Kyoto, 600-8530 Japan
Tel: (81)75-344-7109/Fax: (81)75-344-7149

Regional Headquarters

OMRON EUROPE B.V.

Wegalaan 67-69, NL-2132 JD Hoofddorp
The Netherlands
Tel: (31)2356-81-300/Fax: (31)2356-81-388

OMRON ELECTRONICS LLC

1 East Commerce Drive, Schaumburg, IL 60173
U.S.A.
Tel: (1)847-843-7900/Fax: (1)847-843-8568

OMRON ASIA PACIFIC PTE. LTD.

83 Clemenceau Avenue,
#11-01, UE Square,
Singapore 239920
Tel: (65)6835-3011/Fax: (65)6835-2711

OMRON (CHINA) CO., LTD.

Room 2211, Bank of China Tower,
200 Yin Cheng Zhong Road,
PuDong New Area, Shanghai, 200120 China
Tel: (86)21-5037-2222/Fax: (86)21-5037-2200

OMRON

Authorized Distributor: