

Frequency/Rate Meter K3MA-F

CSM_K3MA-F_DS_E_4_1

Highly Visible LCD Display with 2-color (Red and Green) LEDs

- Contact, NPN, PNP, or voltage pulse input.
- Front-panel key operation for easy setting.
- Average processing function suppresses flicker.
- Includes scaling, auto-zero time, startup compensation time functions.
- Easy confirmation of max/min display.
- Short 80-mm depth (measured from edge of face plate).
- Finger protective cover (standard equipment) guards against electric shock.
- Water- and dust-proof NEMA4X (IP66 equivalent) front panel.
- Recognized to U.S. and Canadian requirements under the Component Recognition Program of UL.
- CE marking.
- Built-in external power supply (12 VDC, 40 mA).



 Refer to *Safety Precautions for All Digital Panel Meters*.

Model Number Structure

Model Number Legend

K3MA-F- -

1 2 3

1. Input Type

F: Rotary pulse

2. Output Type

None: No output

A2: 2 relay contact outputs (SPST-NO)

3. Supply Voltage

100-240VAC: 100 to 240 VAC

24VAC/VDC: 24 VAC/VDC

Ordering Information

List of Models

Input type	Supply voltage	Output	Model
Rotary pulse	100 to 240 VAC	None	K3MA-F 100-240VAC
		2 relay contact outputs (SPST-NO)	K3MA-F-A2 100-240VAC
	24 VAC/VDC	None	K3MA-F 24VAC/VDC
		2 relay contact outputs (SPST-NO)	K3MA-F-A2 24VAC/VDC

Rubber Packing

Model
K32-P1

Note: Rubber packing is provided with the Controller.

Accessories (Order Separately)

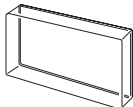
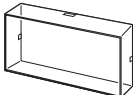
Name	Shape	Model
Splash-proof Soft Cover		K32-49SC
Hard Cover		K32-49HC

■ Characteristics

Input signal	No-voltage contact (30 Hz max., ON/OFF pulse width: 15 ms min.) Voltage pulse (5 kHz max., ON/OFF pulse width: 90 μs min., ON voltage: 4.5 to 30 V/OFF voltage: 0 to 2 V) Open collector (5 kHz max., ON/OFF pulse width 90 μs min.) Connectable Sensors ON residual voltage: 2.5 V max. OFF leakage current: 0.1 mA max. Load current: Must have switching capacity of 15 mA min. Must be able to dependably switch a load current of 5 mA max.
Measuring accuracy	±0.1%FS ±1 digit (at 23±5°C)
Measurement method	Cycle measurement
Max. displayed digits	5 digits (-19999 to 99999)
Display	7-segment digital display, Character height: 14.2 mm
Polarity display	"-" is displayed automatically with a negative input signal.
Zero display	Leading zeros are not displayed.
Scaling function	Programmable with front-panel key inputs (range of display: -19999 to 99999). The decimal point position can be set as desired.
Hold function	Max hold (maximum value), Min hold (minimum value)
Hysteresis setting	Programmable with front-panel key inputs (0001 to 9999).
Other functions	Scaling teach function Display color change (green (red), green, red (green), red) OUT type change (upper limit, lower limit, upper/lower limit) Average processing (simple average OFF/2/4/8 operations) Auto-zero time Startup compensation time Setting change lockout Parameter initialization Display auto-return time
Output	Relays: 2 SPST-NO
Delay in comparative outputs	750 ms max.
Degree of protection	Front panel: NEMA4X for indoor use (equivalent to IP66) Rear case: IEC standard IP20 Terminals: IEC standard IP00 + finger protection (VDE0106/100)
Memory protection	Non-volatile memory (EEPROM) (possible to rewrite 100,000 times)

■ Measuring Ranges

No-voltage Contact/Open Collector Inputs

Input	Measuring range	Measuring accuracy	Displayable range
No-voltage contact (30 Hz max.) with ON/OFF pulse width of 15 ms min.	0.05 to 30.00 Hz	±0.1% FS ±1 digit max. (at 23±5°C)	-19999 to 99999 (with scaling function)
Open collector (5 kHz max.) with ON/OFF pulse width of 90 μs min.	0 to 5 kHz		

■ Input/Output Ratings

Relay Contact Output

Item	Resistive load (cosφ = 1)	Inductive load (cosφ = 0.4, L/R = 7 ms)
Rated load (UL ratings)	5 A at 250 VAC, 5 A at 30 VDC	1 A at 250 VAC, 1 A at 30 VDC
Rated carry current	5 A max. (at COM terminal)	
Max. contact voltage	250 VAC, 150 VDC	
Max. contact current	5 A (at COM terminal)	
Max. switching capacity	1,250 VA, 150 W	250 VA, 30 W
Min. permissible load (P level, reference value)	10 mA at 5 VDC	
Mechanical life	5,000,000 times min. (at a switching frequency of 1,200 times/min)	
Electrical life (at an ambient temperature of 20°C)	100,000 times min. (at a rated load switching frequency of 10 times/min)	

Connections

Terminal Arrangement

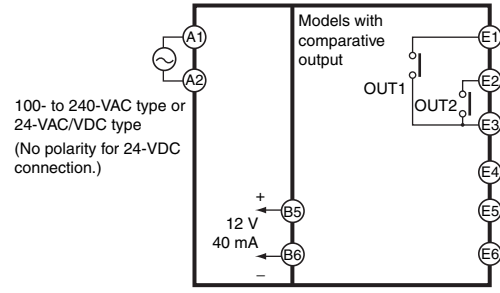
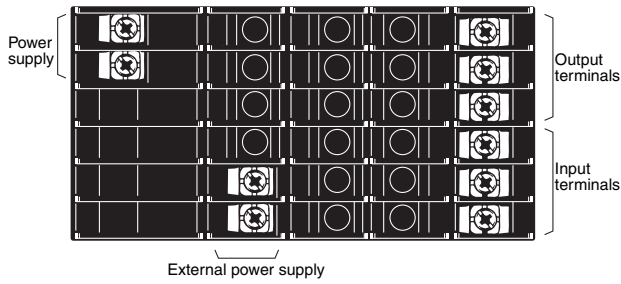

Note: Refer to *Input Circuits* on page 5.

Terminal No.	Name	Description
A1 - A2	Operation power	Connects the operation power supply.
E4, E6 - E5	Pulse input	No-voltage contact/open collector input
E1, E2 - E3	Outputs	Outputs the relay outputs.
B5 - B6	External power supply	Use as the power supply for sensors.

Block Diagram

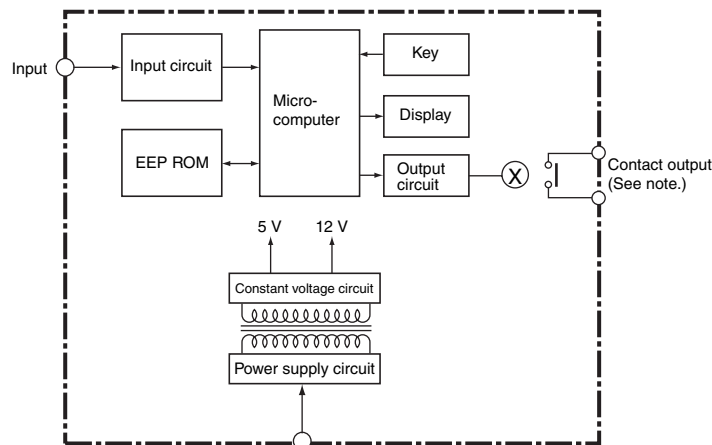

Note: Relay output models only.

Input Circuits

Pulse Input

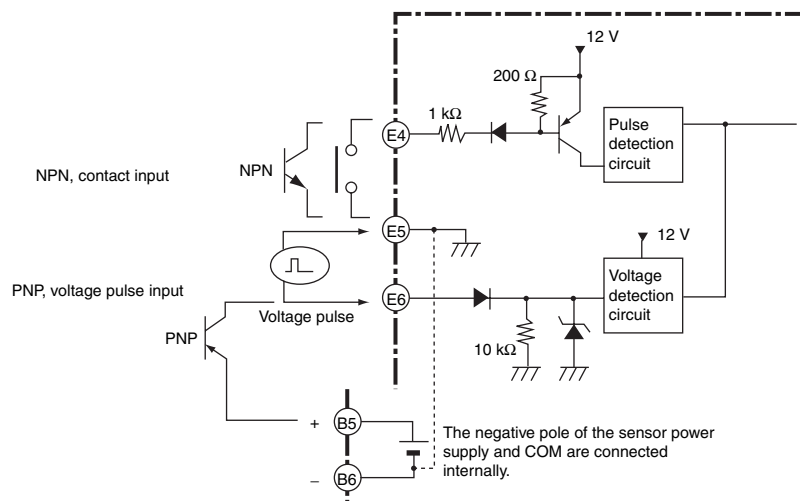

Operation

■ Main Functions

Input Types and Ranges

Frequency range (setting parameter)	Function	Input range (setting parameters)	Setting range
Pulse frequency selection (P-FrE)	Selects pulse input signal.	0.05 to 30.00 Hz (30)	Displayable from -19999 to 99999 with scaling function. The position of the decimal point can be set as desired.
		0 to 5 kHz (5P)	

Pulse Frequency Selection

Parameter	Setting value	Meaning
P-FrE	30	0.05 to 30.00 Hz measurement range
	5P	0 to 5 kHz measurement range

Note: The default value is “0 to 5 kHz (5P).”

Scaling

When the desired display value is set for a corresponding input, the value will be displayed on a line between two points determining the zero point.

Parameter	Setting value	Meaning
LnP	0 to 99999	Input value for dSP
dSP	-19999 to 99999	Display value for LnP

Parameter	Setting value	Meaning
dP	0.0000	Display four digits after decimal point
	00.000	Display three digits after decimal point
	000.00	Display two digits after decimal point
	0000.0	Display one digit after decimal point
	00000	No decimal point

Note: The initial value will change depending on the pulse frequency selection.

- The decimal point can be optionally displayed.
- When displaying the decimal point, consider the number of digits to follow the decimal point prior to setting the scaling display value.
- If P-FrE is set to 30, the initial setting for the decimal display will be 000.00.

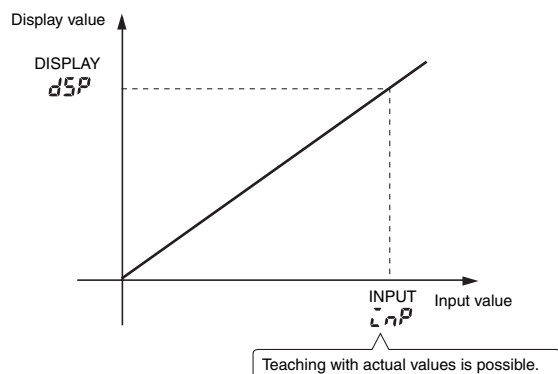

Instead of setting by inputting with the Up Key and Shift Key, current values can be input as scaling input values for teaching. This is useful for making settings while checking the operation status of the K3MA-F.

Convenient Functions

Scaling Teach

The parameter ($\bar{c}n\bar{p}$) for the K3MA-F's initial setting level can be set using actual input values with the teaching function. After displaying the parameter, the actual input settings can be made with the following operation.

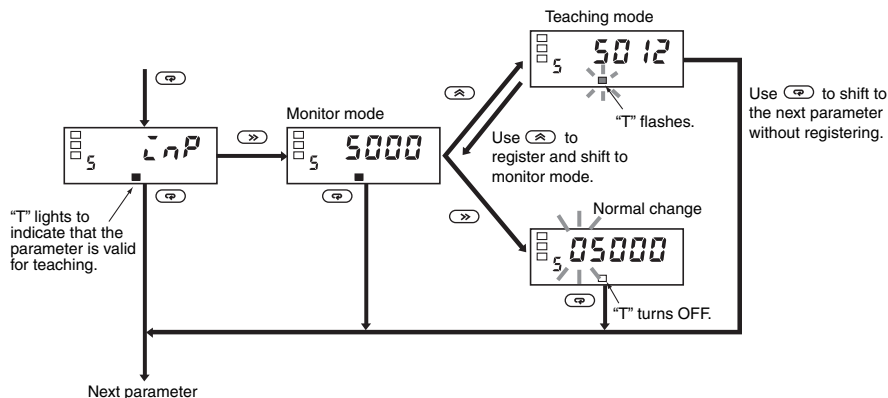

OUT Types (Comparative Output Models Only)

OUT 1 and OUT 2 can be set to operate in one of the three following modes in accordance with the compared values:

- Upper limit (High Acting):
The output is turned ON when the measurement value is greater than its set value.
- Lower limit (Low Acting):
The output is turned ON when the measurement value is less than its set value.

- Upper and lower limits (Outside Band Acting):
An upper limit (H set value) and lower limit (L set value) can be set independently.
The output is turned ON when the measurement value is greater than upper-limit set value or less than the lower-limit set value.

Parameter	Set value	Meaning
$\bar{a}u\bar{t} \bar{h}$ or $\bar{a}u\bar{t} \bar{l}$	$H\bar{c}$	Upper limit: Upper-limit alarm operation
	$L\bar{c}$	Lower limit: Lower-limit alarm operation
	$H\bar{c} - L\bar{c}$	Upper and lower limits: Upper- and lower limit alarm operation

Upper Limit (High Acting)

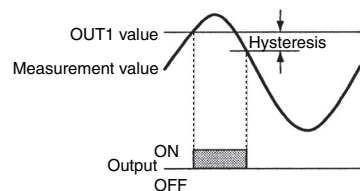

Lower Limit (Low Acting)

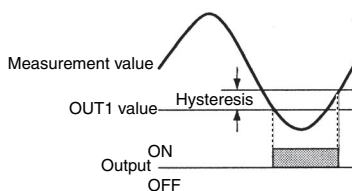

Upper and Lower Limits (Outside Band Acting)

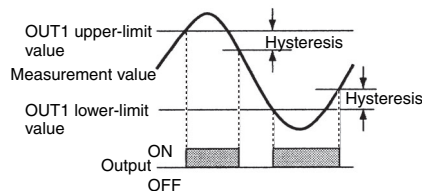

The three types of output operations shown above can be combined as desired. The following are examples of possible combinations.

Upper Limit 2-stage Output

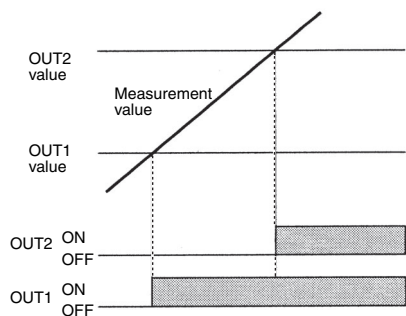

Threshold Output

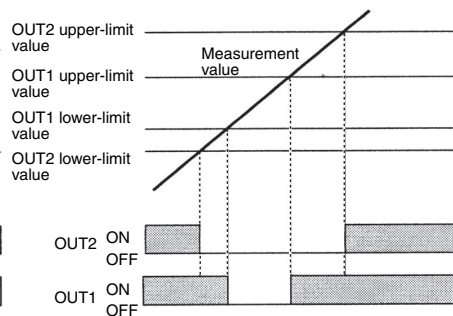

Combination of Upper Limit and Upper/Lower Limits

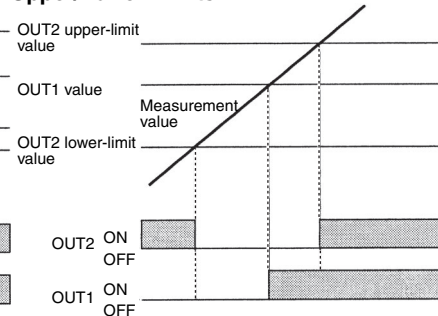

Parameter Initialization

This function returns all of the parameters to their initial values.

Parameter	Setting value	Meaning
$\bar{c}n\bar{c}$	$\bar{a}ff$	---
	$\bar{a}n$	Initializes all parameters.

Use this to reset the K3MA-F after returning it to its factory-set condition.

Average Processing

Average processing stabilizes the display by minimizing any pulsating or flicker caused by fluctuations in the pulse width of sensor input or by eccentricity in rotating shafts.

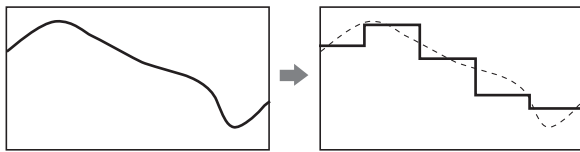

Hysteresis (Comparative Output Models Only)

The hysteresis of comparative outputs can be set to prevent chattering in the output when the measurement value fluctuates finely near the OUT value.

Upper limit (high acting)

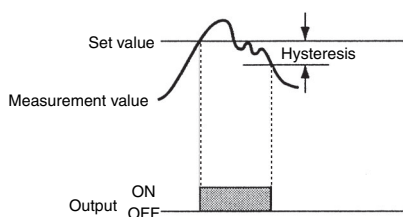

Auto-zero Time

This function sets the time for the display to return to zero when input pulses stop. Set the time longer than the expected input pulse cycle (the interval between one input pulse and the next). Proper measurement is not possible if the time is set shorter than the input pulse cycle.

Setting range: 0.0 to 19.9 s

Startup Compensation Time

The startup compensation time is the time to wait for the measurement operation to be entered after the power supply of the K3MA-F is turned ON. Use this parameter to cancel measurement and comparative output operation until the a rotating body reaches its normal speed when the power supply to the K3MA-F and rotating body are turned ON at the same time.

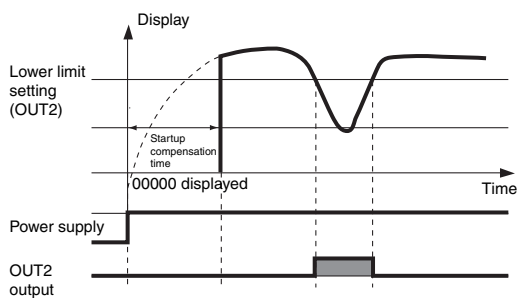

Changing the Display Color

The color of the value displayed can be set to either red or green. For comparative output models, the display color can be set to change from green to red, or from red to green, according to the status of the comparison criterion.

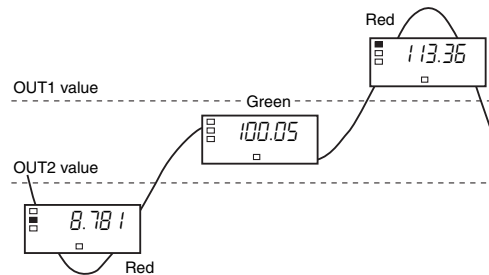

Display Auto-return Time

This function automatically returns the display to the operation level's current value if no keys are pressed for a preset time (called the display auto-return time).

Move-to-Protect-Level Time

The time required to shift to the protect level can be set as desired.

MAX/MIN Display

The maximum and minimum measurement (display) values from the time the power is turned ON until the current time can be stored and displayed. This is useful, for example, when measuring the maximum value.

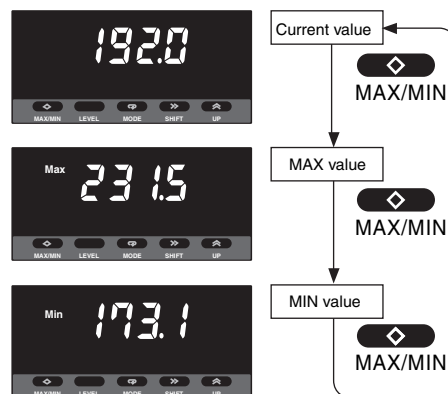

Nomenclature

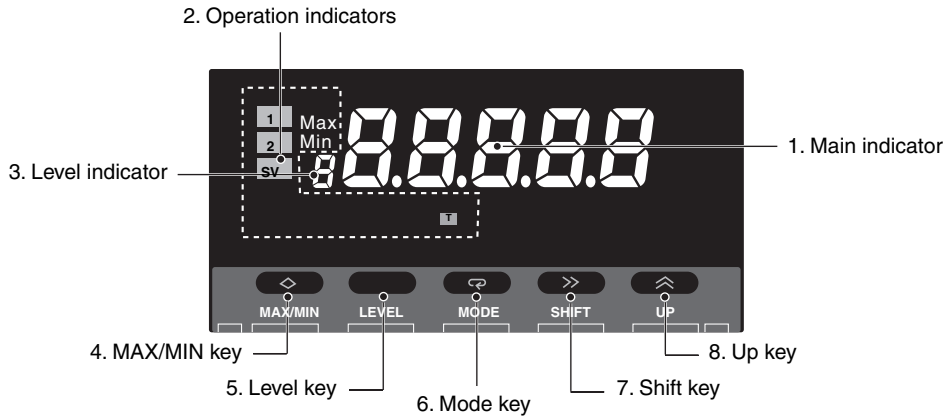

Name	Functions	
1. Main indicator	Displays current values, parameter names (abbreviations), and comparative value settings.	
2. Operation indicators	1	Lit when output 1 is ON.
	2	Lit when output 2 is ON.
	SV	Lit when a set value is being displayed or changed.
	Max	Lit when the main indicator is showing the MAX value.
	Min	Lit when the main indicator is showing the MIN value.
	T	Lit when the teaching function is operable. Blinks while the teaching function is operating.
3. Level indicator	Displays the current level that the K3MA-F is in. (See below for details.)	
4. MAX/MIN Key	Used to display the MAX and MIN values when a measurement value is being displayed.	
5. Level Key	Used to change the level. The level can be switched between operation level and initial setting level.	
6. Mode Key	Used to allow the main indicator to indicate parameters sequentially.	
7. Shift Key	Used to enable a set value to be changed. When changing a set value, this key is used to move along the digits.	
8. Up Key	Used to change a set value. Used to set or clear a forced-zero function when a measurement value is being displayed.	

Level indicator	Level
\overline{P}	Protect
Not lit	Operation
\overline{S}	Initial setting
\overline{F}	Advanced function setting

Dimensions

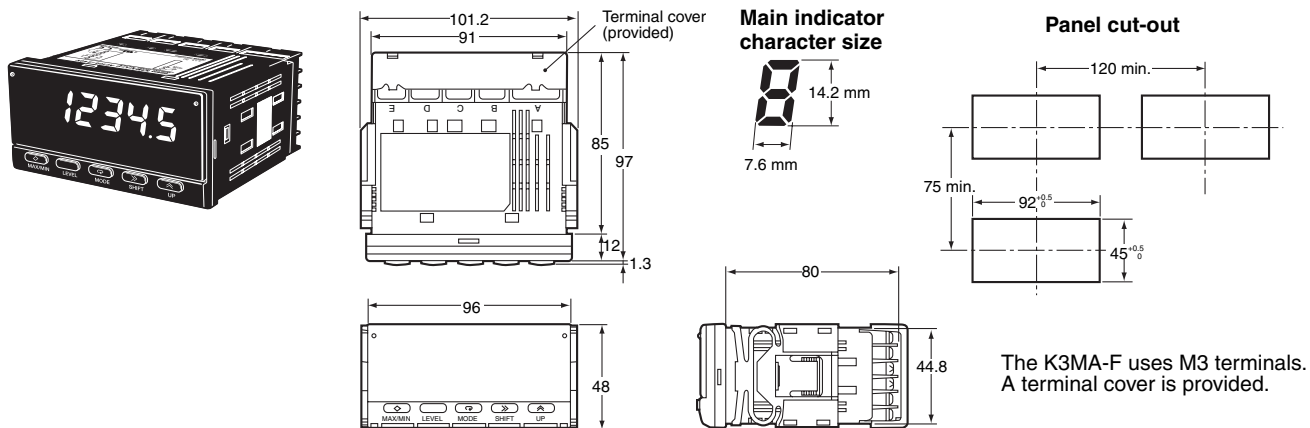

Application Examples

Displaying conveyor belt feed speed

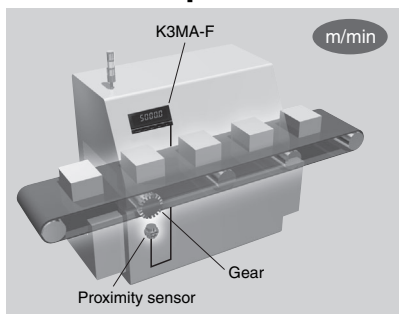

- Monitoring line speed for a reflow furnace
- Displaying feed speed for food processing, conveying, sintering

Monitoring the rotations of a mixer or churner

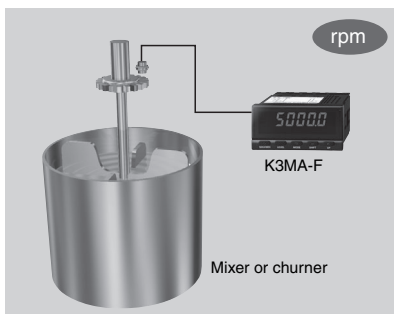

- Mixers for resin molding
- Powdering/pelleting machines, centrifugal separators

Displaying the monitor output from an inverter as rotations or line speed

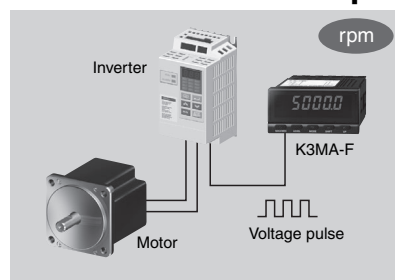

Note: If the monitor output from the inverter is analog, such as 0 to 10 V, use the K3MA-J.

- Monitoring conveyor speed
- Machining equipment (grinders, polishers)

Installation

1. Insert the K3MA-F into the panel cut-out hole.
2. For a waterproof installation, insert the rubber gasket onto the body of the K3MA-F.

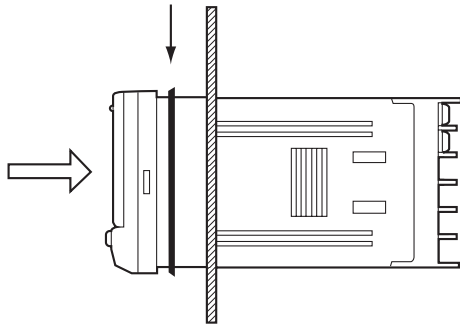

3. Fit the adaptor into the grooves on the left and right sides of the rear case, then push it until it contacts the panel to secure the K3MA-F.

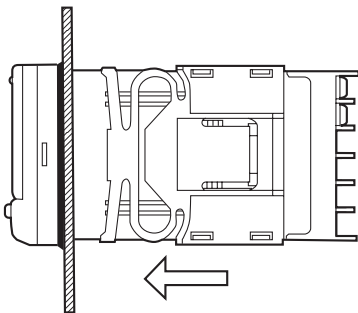

■ LCD Angle of View

The K3MA is designed to provide the best visibility at the angles shown in the following diagram.

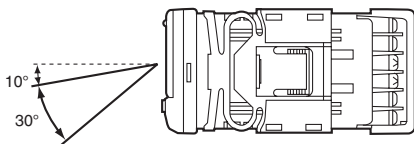

■ Rubber Packing (Sold Separately)

K32-P1

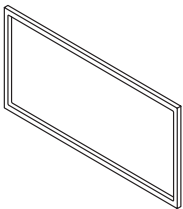

If the rubber packing is lost or damaged, it can be ordered using the following model number: K32-P1.

(Depending on the operating environment, deterioration, contraction, or hardening of the rubber packing may occur and so, in order to ensure the level of waterproofing specified in NEMA4, periodic replacement is recommended.)

Note: Rubber packing is provided with the Controller.

■ Wiring Precautions

- Use crimp terminals.
- Tighten the terminal screws to a torque of approximately 0.5 N·m.
- To avoid the influence of noise, route signal lines and power lines separately.

■ Wiring

- Use the following M3 crimp terminals.

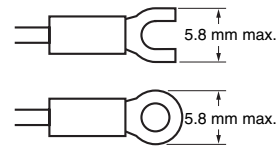

■ Unit Labels (Provided)

- The unit labels are not attached to the K3MA-F. Select the desired labels from the provided sheet.

V	A	V	A	%	J	Pa	Ω
s	/	N	m	W	°C	m ³	k
°F	g	min	mm	rpm			
VA	mV	mA	Hz				
m/min	OMRON						
OUT	OUT						

Note: For scales and gauges, use the unit labels that are specified by the relevant laws or regulations.

Operating Procedures

Operations in Run Mode

Checking the Maximum and Minimum Values

The maximum and minimum values can be displayed by pressing the MAX/MIN Key while the measurement is being displayed.

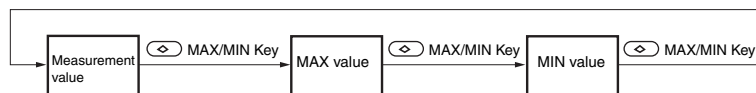

The maximum and minimum values can be reset by pressing the MAX/MIN Key for 1 s min. when the maximum or minimum value is displayed.

Checking and Setting Comparative Set Values (for Models with the Comparative Output Function)

Each time the Mode Key is pressed when the measurement value, maximum value, or minimum value is displayed, the comparative values will be displayed in the following order: OUT1 value (or OUT1 upper-limit value, OUT1 lower-limit 1), OUT 2 value (or OUT2 upper-limit value, OUT2 lower limit value 2).

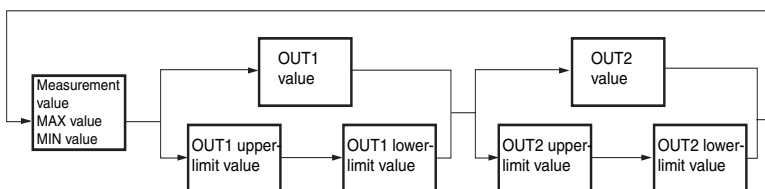

Note: When the comparative value is displayed, it can be changed by pressing the Shift Key and the Up Key (when key protection is OFF).

Levels

“Level” refers to a grouping of parameters. The following table lists the operations that are possible in each of the levels, and the diagram tells how to move between levels. There are some parameters that are not displayed for certain models.

Level name	Function	Measurement
Protect	Setting lockouts.	Continue
Operation	Displaying current values, and setting OUT 1/2 set values.	Continue
Initial setting	Making initial settings of input type, scaling, output operating action, and other parameters.	Stopped
Advanced function setting	Setting average processing, display color settings, and other advanced function parameters.	Stopped

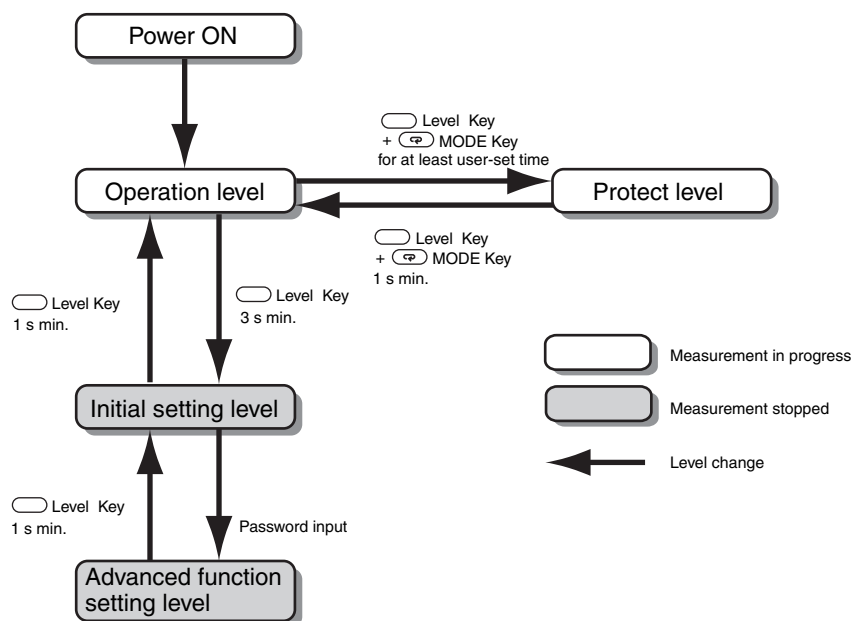

Parameters

- Note:**
1. Some parameters are not displayed for certain models.
 2. The K3MA-F will stop measurement if the level is changed to the initial setting level or the advanced-function setting level.
 3. If the input range is changed, some parameters are set to default values. Therefore, set the input range first.
 4. Settings displayed in reversed colors are defaults.

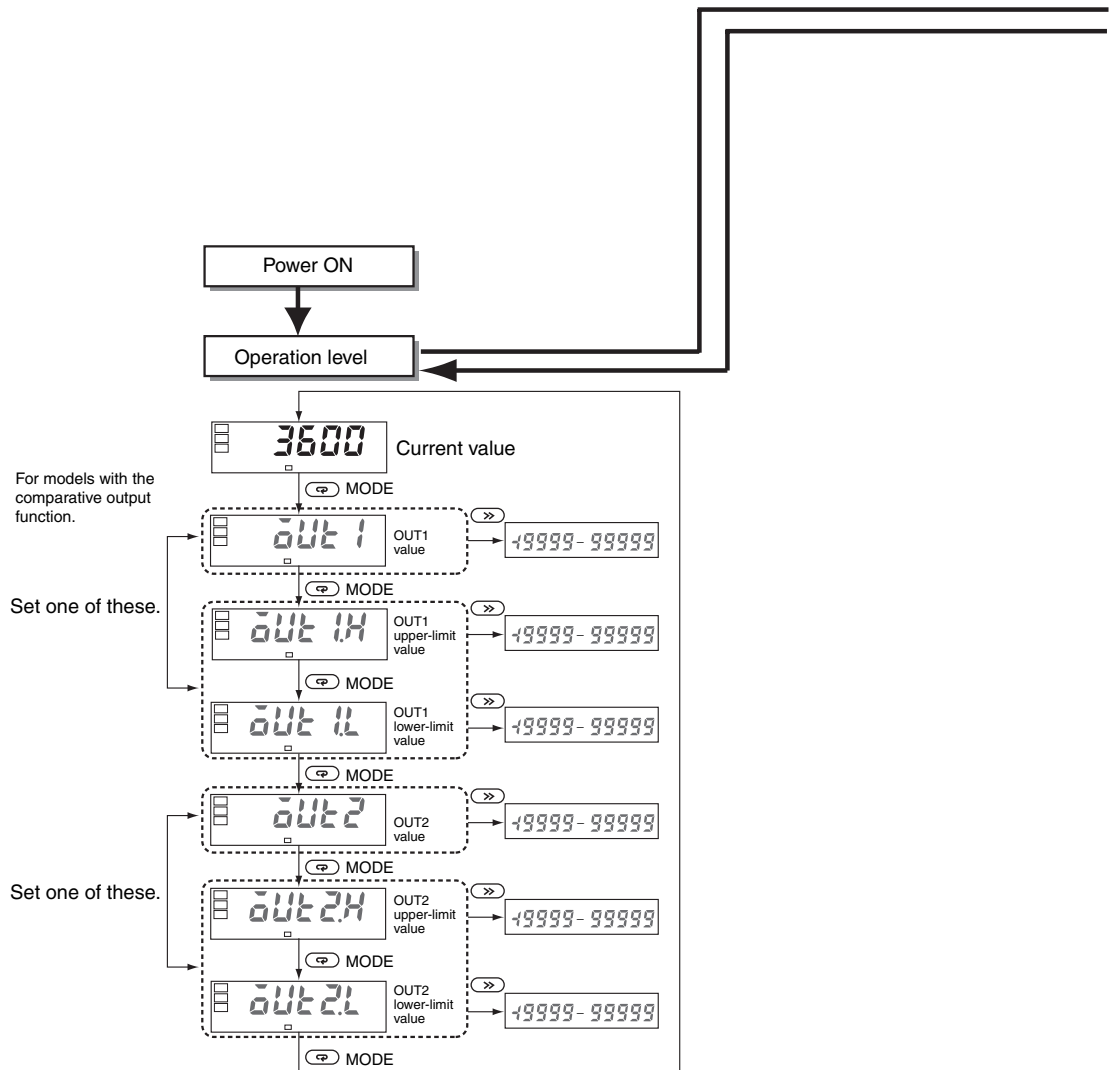

Press Level Key \square for more than 3 s.

To change a setting, press the Shift Key \gg again, and then make the change with the Up Key \uparrow .

Press Level Key \square for less than 1 s.

Press Level Key \square for more than 1 s.

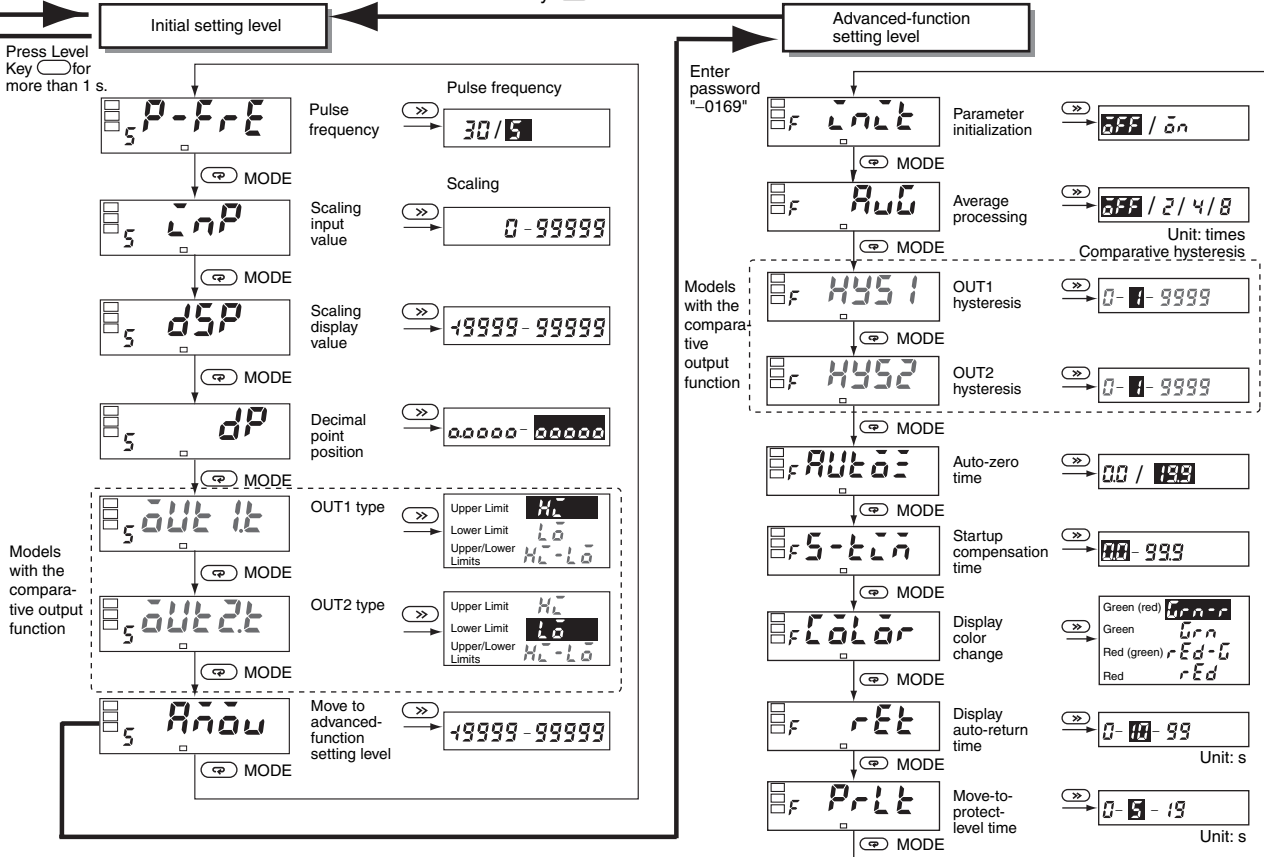

Settings displayed in reversed colors are initial settings.

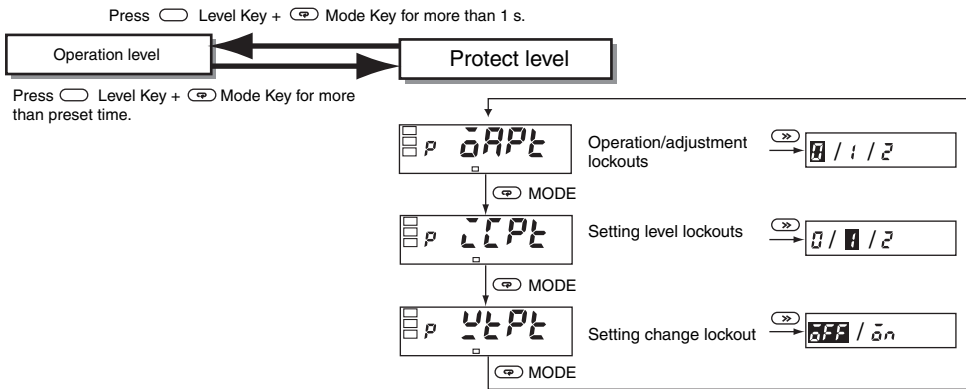

Operation/Adjustment Lockouts

Restricts key operations for operation level and adjustment level.

Parameter	Setting	Operation level	
		Current value display	Set value display
0APL	0	Allowed	Allowed
	1	Allowed	Allowed
	2	Allowed	Prohibited

- Initial setting is 0.
- This is not displayed on models with no comparative output function.

Setting Level Lockouts

Restricts shifting to initial setting level or advanced function setting level.

Parameter	Setting	Shift to initial setting level	Shift to advanced function setting level
LCPLE	0	Allowed	Allowed
	1	Allowed	Prohibited
	2	Prohibited	Prohibited

Setting Change Lockout

Restricts setting changes by key operation. When this lockout is set, it is no longer possible to shift to a setting change mode.

Parameter	Setting	Setting change by key operation
ULPLE	OFF	Allowed
	ON	Prohibited

However, all protect level parameters can still be changed.

Initial Settings

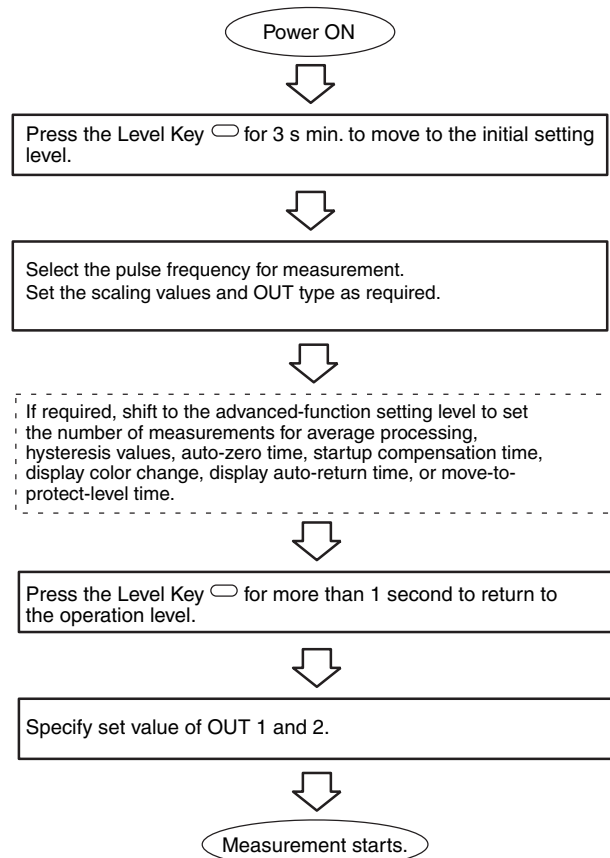

Setting Example

Initial Settings

The settings for the following example are shown here.

Example: Display conveyor belt feed speed

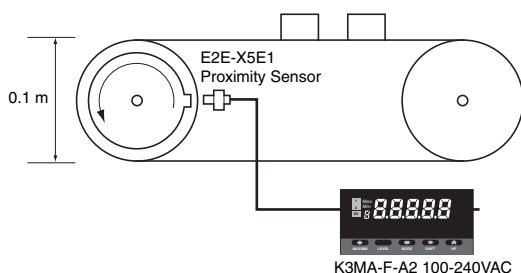

Here, the conveyor belt feed speed is to be displayed in units of 0.1 m/min.

- Proximity Sensor: E2E-X5E1, NPN output

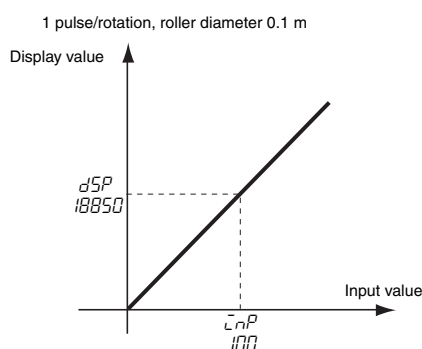

When displaying a flowrate (e.g., in l/min or l/h), make the scaling settings after confirming the I/O characteristics of the flowrate sensor. There are flowrate sensors that output analog signals. If this kind of flowrate sensor is used, consider using the K3MA-J.

Troubleshooting

When an error occurs, error details will be displayed on the main indicator. Confirm the error from the main indicator and take the appropriate countermeasures.

Level display	Main indicator	Error contents	Countermeasures
Not lit	E 111	RAM memory error	Repair is necessary. Consult your OMRON sales representative.
5	E 111	EEPROM memory error	When this error is displayed, press the Level Key for 3 seconds, and the settings will be restored to the factory settings. If the error cannot be recovered, repair is necessary. Consult your OMRON sales representative.
Not lit	Flashes 99999	The scaling display value exceeds 99999.	Promptly change the input to a value that falls within the specified range. The scaling value may be inappropriate. Review the scaling value at the initial setting level.
Not lit	Flashes -19999	The scaling display value is lower than -19999.	Promptly change the input to a value that falls within the specified range. The scaling value may be inappropriate. Review the scaling value at the initial setting level.

- Select the maximum input frequency for the K3MA-F. Set the pulse frequency selection to either 30 Hz or 5 kHz. In the example, this is set to 30 Hz because the conveyor belt is turning at a slow speed.

Parameter: P-FrE (pulse frequency), Setting value: 30

- Set the scaling. The display value (D) is shown with the following formula.

$$D = f \times \alpha$$

f: frequency and
α: prescaling value

The value of α will be internally calculated and registered if the input value (f) and the display value (D) are set.

The number of rotations or speed is shown with the following formula.

$$\text{Rotations (rpm)} = \frac{\text{Frequency input}}{\text{No. of pulses per rotation}} \times 60$$

$$\text{Cycle speed D (m/min)} = \frac{\text{Rotations} \times \text{roll circumference}}{60}$$

N: No. of pulses per rotation
f: Frequency (Hz)
d: Roller diameter (m)

When the input conditions are applied to this equation, we obtain the following:

$$\text{Display value} = 1/1 \times f \times 60 \times 0.1 \times \pi$$

For an input of 1 Hz, the display value is 18.8495 (m/min).

The scaling settings for the K3MA-F must be integers. Also, to decrease error, the scaling value is multiplied by 1,000, to obtain an input of 1000 Hz and a display value of 18850. However, because the display value in this case is displayed to the first decimal place, the scaling is set as shown in the following example so that 1885.0 is displayed for an input of 100 Hz.

Parameter	Setting value
LnP (scaling input value)	100
d5P (scaling display value)	18850
dP (decimal point position)	0000.0

Note: The decimal point position here refers to the position in the number after scaling. When setting the scaling display value, it is necessary to consider the number of digits to be displayed past the decimal point.

ALL DIMENSIONS SHOWN ARE IN MILLIMETERS.

To convert millimeters into inches, multiply by 0.03937. To convert grams into ounces, multiply by 0.03527.

In the interest of product improvement, specifications are subject to change without notice.