

Terminal Protective Cover, Seal Rubber, and Rubber Packing

(The Switch is equipped with these 3 items as a standard.)

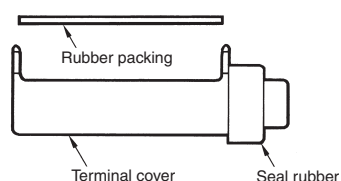

- ZC Terminal Cover
(Product code: ZC55-0002H)
- ZC Seal Rubber
(Product code: SC-1404C)
- ZC Rubber Packing
(Product code: ZC55-9999G)

Specifications

■ Approved Standards

(Except Molded Terminal Models and Operation Indicator-equipped Model)

Agency	Standard	File No.
UL	UL508	E76675
CSA	C22.2, No. 14	LR45258
TÜV Rheinland	EN60947-1, EN60947-5-1	J9650089

■ Approved Standard Ratings

UL/CSA

A300

Voltage	Carry current	Current		Volt-amperes	
		Make	Break	Make	Break
120 VAC	10 A	60 A	6 A	7,200 VA	720 VA
240 VAC		30 A	3 A		

Micro load	0.1 A, 125 VAC 0.1 A, 30 VDC
------------	---------------------------------

TÜV Rheinland

250 V, 10 A (AC12)

■ Ratings

Rated voltage	Non-inductive load				Inductive load			
	Resistive load		Lamp load		Inductive load		Motor load	
	NC	NO	NC	NO	NC	NO	NC	NO
125 VAC	10 A		3 A	1.5 A	10 A		5 A	2.5 A
250 VAC	10 A		2.5 A	1.25 A	10 A		3 A	1.5 A
8 VDC	10 A		3 A	1.5 A	6 A		5 A	2.5 A
14 VDC	10 A		3 A	1.5 A	6 A		5 A	2.5 A
30 VDC	6 A		3 A	1.5 A	5 A		5 A	2.5 A
125 VDC	0.5 A		0.4 A	0.4 A	0.05 A		0.05 A	0.05 A
250 VDC	0.25 A		0.2 A	0.2 A	0.03 A		0.03 A	0.03 A

Inrush current	NC	30 A max.
	NO	15 A max.

- Note:**
1. The above figures are for steady-state currents.
 2. Inductive loads have a power factor of 0.4 min. (AC) and a time constant of 7 ms max. (DC).
 3. Lamp load has an inrush current of 10 times the steady-state current.
 4. Motor load has an inrush current of 6 times the steady-state current.
 5. The above ratings were tested under the following conditions according to JIS C4508.
 Ambient temperature: 20±2°C
 Ambient humidity: 65±5%
 Operating frequency: 20 operations/min

■ Characteristics

Degree of protections	IP67
Durability	Mechanical: 10,000,000 operations min. Electrical: 500,000 operations min.
Operating speed	0.05 mm to 0.5 m/s (at pin plunger)
Operating frequency	Mechanical: 120 operations/min Electrical: 20 operations/min
Insulation resistance	100 MΩ min. (at 500 VDC)
Contact resistance	15 mΩ max. (initial value)
Dielectric strength	1,000 VAC, 50/60 Hz for 1 min between non-continuous terminals 2,000 VAC, 50/60 Hz for 1 min between current-carrying metal part and ground, and between each terminal and non-current-carrying metal parts
Rated insulation voltage (U _i)	1,000 VAC
Pollution degree (operating environment)	3 (IEC947-5-1)
Short-circuit protective device	10 A-fuse type gG (IEC 269)
Protection against electric shock	Class II
PT1 (tracking characteristics)	175
Switch category	D (IEC335)
Rated operating current (I _e)	10 A
Rated operating voltage (U _e)	250 VAC
Vibration resistance	Malfunction: 10 to 55 Hz, 1.5-mm double amplitude (see note)
Shock resistance	Destruction: 1,000 m/s ² max. Malfunction: 300 m/s ² max. (at pin plunger) (see note)
Ambient temperature	Operating: -10°C to 80°C (with no icing)
Ambient humidity	Operating: 35% to 95%
Weight	Approx. 92 g (in case of ZC-Q22(21)55)

Note: Less than 1 ms under a free state at the operating limits.

■ Operating Characteristics

Model	ZC-D55	ZC-Q55	ZC-Q2255	ZC-Q2155	ZC-N2255	ZC-N2155
OF max.	11.8 N	11.8 N			6.86 N	
RF min.	4.90 N	4.90 N			1.67 N	
PT max.	1.5 mm	1.5 mm			1.5 mm	
OT min.	2.4 mm	3 mm			2.5 mm	
MD max.	0.2 mm	0.2 mm			0.2 mm	
OP	32.4±0.8 mm	38.2±0.8 mm	47.4±0.8 mm			

Model	ZC-W55	ZC-W155	ZC-W255	ZC-W2155	ZC-W355	ZC-W3155
OF max.	3.92 N	2.75 N	3.92 N	2.75 N	3.92 N	2.75 N
RF min.	0.78 N	0.59 N	0.78 N	0.59 N	0.78 N	0.59 N
OT min.	6 mm	8.4 mm	6 mm	8.4 mm	6 mm	8.4 mm
MD max.	1 mm	1.4 mm	1 mm	1.4 mm	1 mm	1.4 mm
OP	28.5±1.2 mm	28.5±1.2 mm	43±1.2 mm	43±1.2 mm	53±1.2 mm	53±1.2 mm
FP max.	34.7 mm	36.7 mm	49.2 mm	51.3 mm	59.2 mm	61.2 mm

■ Contact Form

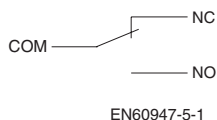
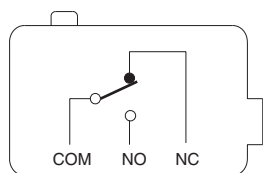

Engineering Data

■ Mechanical Durability (for ZC-Q55)

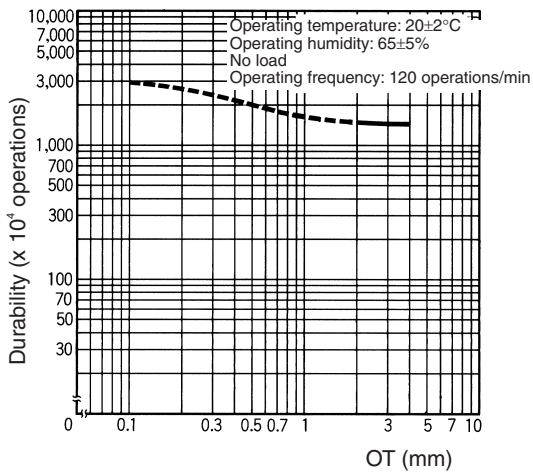

■ Electrical Durability

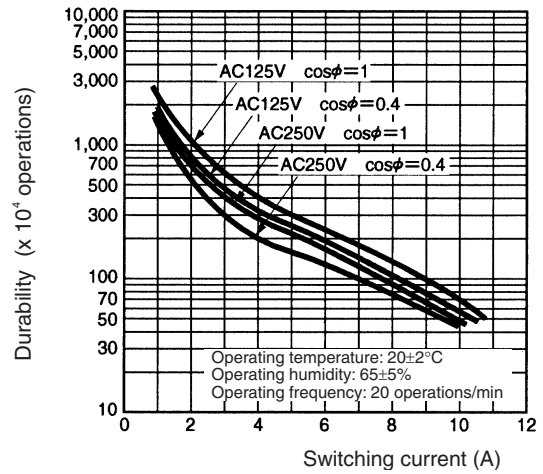

Nomenclature

Changing the Terminal Protective Cover around allows the cable to be pulled out from either the right or the left.

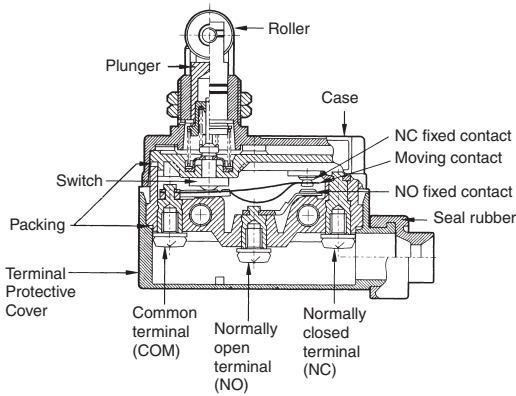

Note: M4 binding head screws (with toothed washers) are used as the terminal screws.

**Panel Mount Roller Plunger
ZC-Q2255**

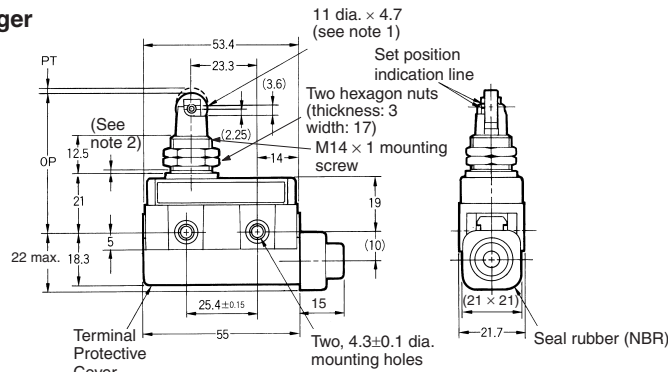

- Note:**
1. Stainless sintered alloy roller
 2. The length of the imperfect threads is 1.5 mm maximum.
 3. Do not use the M14 mounting screw and the case mounting hole at the same time.

**Panel Mount Crossroller Plunger
ZC-Q2155**

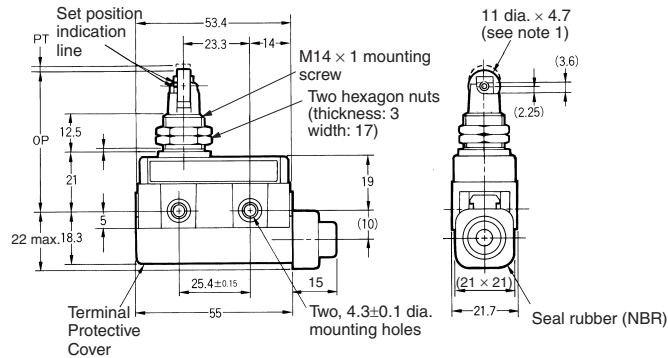

- Note:**
1. Stainless sintered alloy roller
 2. The length of the imperfect threads is 1.5 mm maximum.
 3. Do not use the M14 mounting screw and the case mounting hole at the same time.

**Sealed Roller Plunger
ZC-N2255**

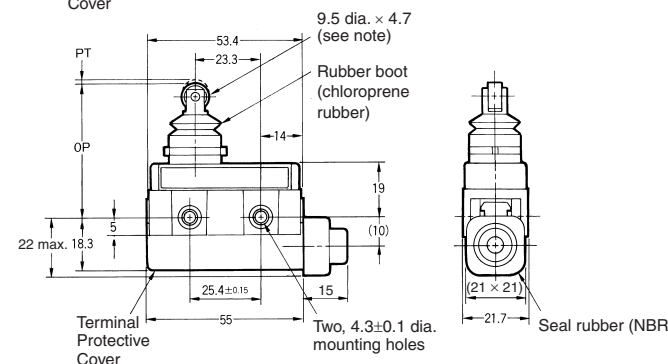

- Note:** Stainless sintered alloy roller

**Sealed Crossroller Plunger
ZC-N2155**

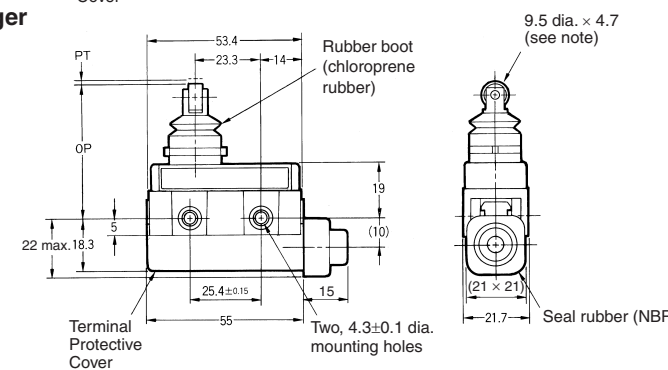

- Note:** Stainless sintered alloy roller

**Short Hinge Roller Lever
ZC-W55**

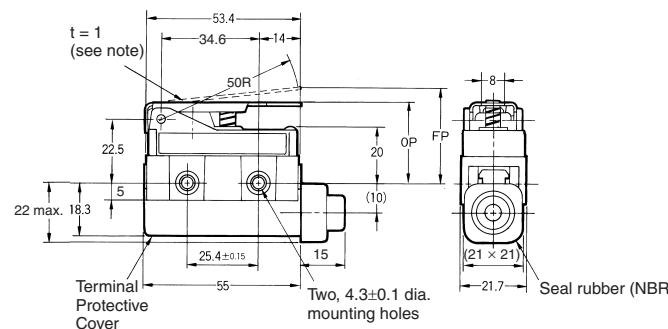

- Note:** Stainless steel lever

**Hinge Lever
ZC-W155**

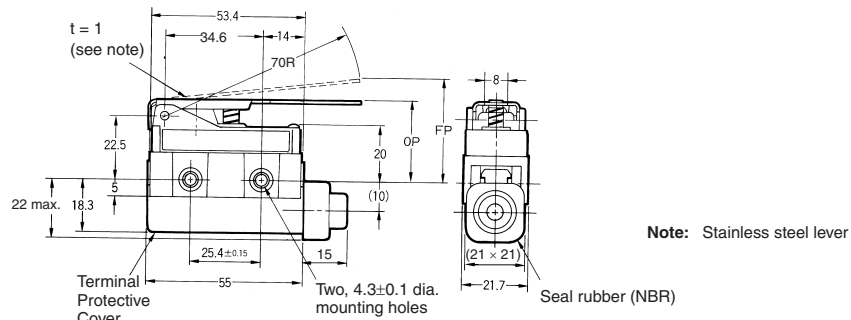

**Short Hinge Roller Lever
ZC-W255**

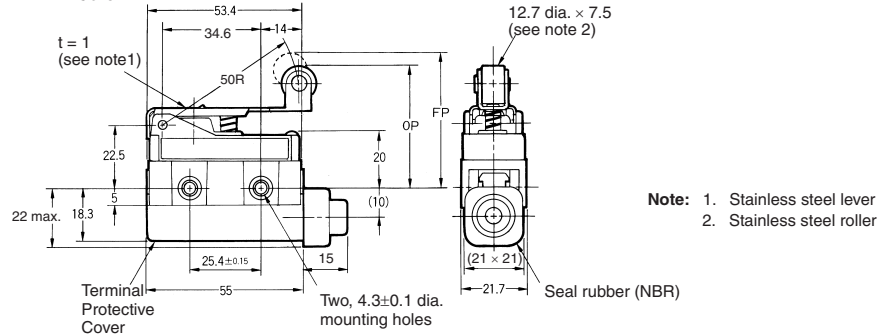

**Hinge Roller Lever
ZC-W2155**

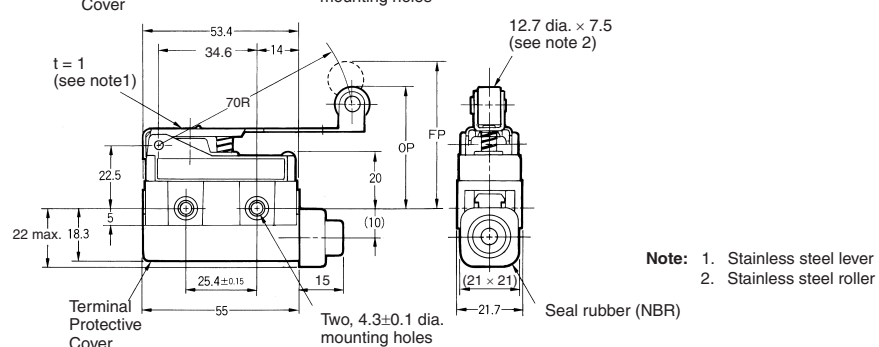

**One-way Action Short Hinge Roller Lever
ZC-W355**

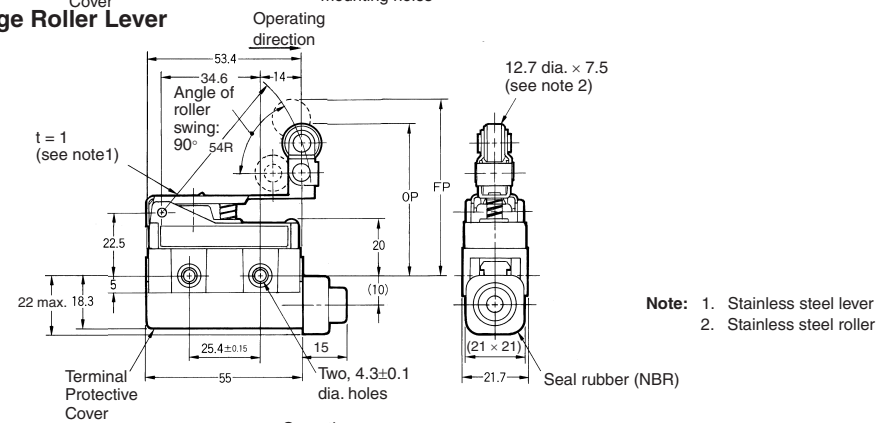

**One-way Action Hinge Roller Lever
ZC-W3155**

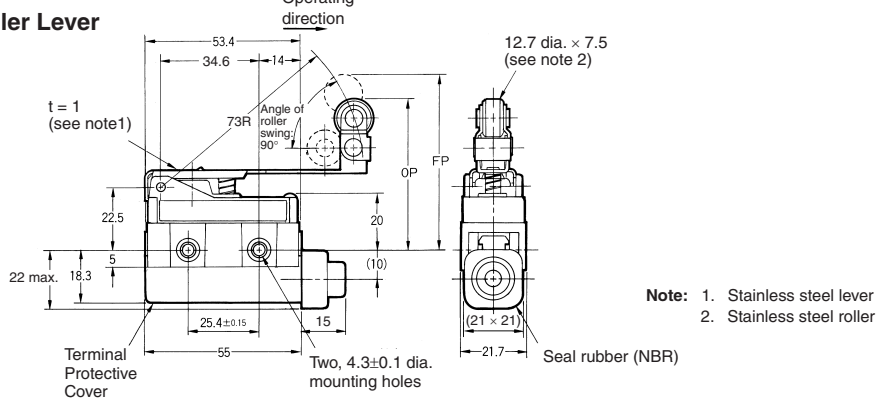

■ Operation Indicator-equipped Models

All the models can be equipped upon request with an operation indicator to facilitate maintenance and inspection.

Because the indicator is incorporated in the Terminal Protective Cover, the dimensions of the Limit Switch are not affected. In this model, the lead wire is to be connected to the screw terminal. (A connecting washer is provided on the tip of the lead wire).

The lead wire can be connected to either the NC or NO terminal.

Operating characteristics are the same as the standard model from which the operation indicator equipped model is fabricated.

AC Operation

The operating voltage range is from 90 to 250 VAC.

The dimensions are the same as the standard type. The top of the Terminal Protective Cover is transparent to allow checking the operation easily.

When placing your order for the indicator equipped, AC-operated model, add suffix "L" to the end of the model number.

Example:

Standard type: ZC-Q2255
Indicator equipped type: ZC-Q2255-L

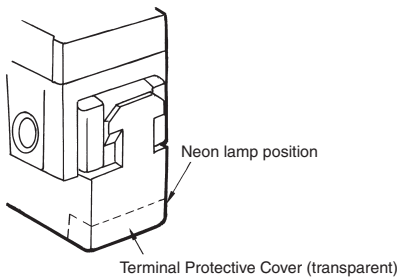

Contact Circuit

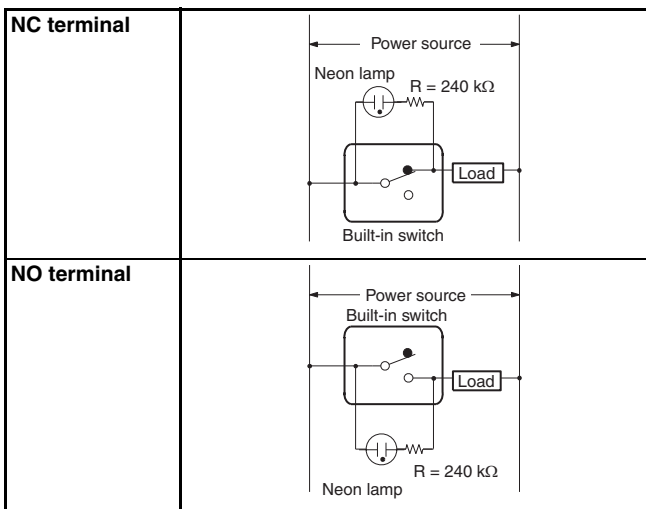

Note: If the wiring is as shown above, the operation of the respective parts will be as follows:

Contact	Neon lamp	Load	Actuator
NC	ON	Does not operate	Operates
	OFF	Operates	Does not operate
NO	ON	Does not operate	Does not operate
	OFF	Operates	Operates

DC Operation

The DC-operated is provided with an LED indicator.

Since a rectifier stack is incorporated into the unit to permit reversing the polarity, this type can also operate on AC power source. An external 24VDC power supply can be used, eg. OMRON S8VS or S82K.

The LED projects from the housing for easy visibility.

When placing your order, add suffix "L2" to "L5" to the model number of the standard type.

Example:

Standard type: ZC-Q2255
Indicator equipped type: ZC-Q2255-L2

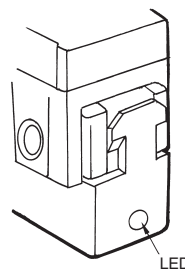

Type	Voltage rating	Leakage current	Internal resistance
L2	12 V	Approx. 2.4 mA	4.3 kΩ
L4	24 V	Approx. 1.2 mA	18 kΩ

Contact Circuit

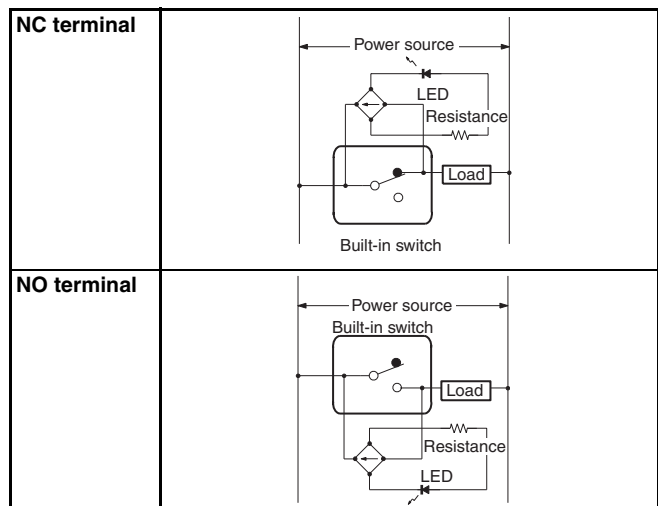

Note: If the wiring is as shown above, the operation of the respective parts will be as follows:

Contact	LED	Load	Actuator
NC	ON	Does not operate	Operates
	OFF	Operates	Does not operate
NO	ON	Does not operate	Does not operate
	OFF	Operates	Operates

Molded Terminal Models

Molded Terminal Model

The molded-terminal model is available with right-hand, left-hand and underside leads and is recommended for use where the Switch is exposed to dust, oil or moisture.

The molded-terminal model is not approved by UL and CSA.

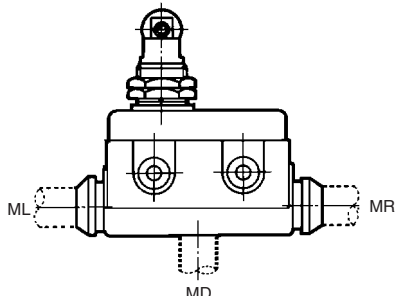

Note: When placing your order for the Switch, specify the required length of V.C.T. cable in addition to the model number of the Switch.

Example:

Standard type: ZC-Q2155

Location of lead output: Underside

Length of lead: 1 m (V.C.T. lead)

When placing your order for the above Switch, specify the model number as ZC-Q2155-MD VCT 1 m.

Suffix by Location of Lead Outlet

Location of lead output	Model
	COM, NC and NO
Right-hand	ZC-□-MR
Left-hand	ZC-□-ML
Underside	ZC-□-MD

Lead Supplies

Leads	Nominal cross-sectional area	Finished outside diameter	Terminal connections	Standard length
V.C.T. (vinyl cabtire cable)	1.25 mm ²	3 core: 10.5 dia.	Black: COM White: NO Red: NC	1, 3, 5 m

Limit Switches

Precautions

■ Correct Use

Dog Angle

When operating the roller type, be sure to set the dog angle to less than 30° (even when operating at a low speed). Operating the model at a dog angle exceeding 30° will soon cause abrasion or damage. Do not apply a twisting force to the plunger. Set the OT to 70% to 100% of the specified value so that the actuator will not exceed the OT.

Handling

When detaching the Terminal Protective Cover, insert a screwdriver and apply a force in the opening direction. Do not use excess force to remove the cover. Doing so may cause deformation in the fitting section and reduce the holding force.

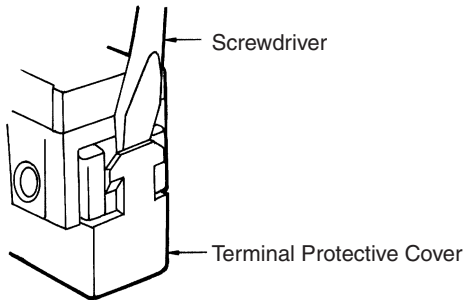

When mounting the Terminal Protective Cover to the case, align the cover on the case and then press the cover down to mount it firmly. If the cover is pressed down in an inclined position, rubber packing will deform and thus affect the sealing capability.

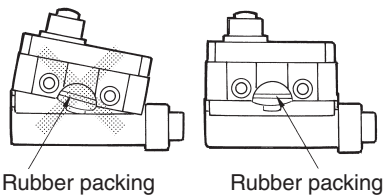

- A 8.5- to 10.5-dia. cable can be applied as seal rubber for the lead wire outlet. (Use two- or three-core cable of VCT1.25 mm².)
- Use weather-proof rubber (chloroprene rubber) as seal rubber for the ZC-N22(21)55.

Mounting

- When mounting the Switch with screws on a side surface, fasten the Switch with M4 screws and use washers, spring washers, etc., to ensure secure mounting.

Mounting Holes

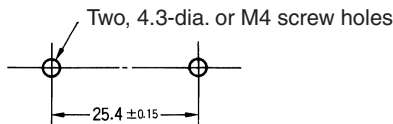

- When mounting the Panel Mount-type Enclosed Switch (ZC-Q55, ZC-Q2255, or ZC-Q2155) with screws on a side surface, remove the hexagonal nuts from the actuator.

Mounting Hole Dimensions

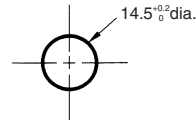

Tightening Torque

A loose screw may result in a malfunction. Be sure to tighten each screw to the proper tightening torque as shown below.

No.	Type	Torque
1	Terminal screw	0.78 to 1.18 N·m
2	Panel mounting screw	4.90 to 7.84 N·m
3	Side mounting screw	1.18 to 1.47 N·m

Operation

With the ZC-Q22(21)55, an appropriate OT line is marked on the plunger. Set the OT so that it is between the two X-surface lines.

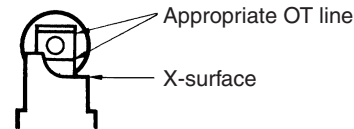

Micro-load Applicable Ranges

Using a standard load switch for opening and closing a micro-load circuit may cause wear on the contacts. Use the switch within the operating range. (Refer to the diagram below.) Even when using micro-load models within the operating range shown below, if inrush current occurs when the contact is opened or closed, it may cause the contact surface to become rough, and so decrease life expectancy. Therefore, insert a contact protection circuit where necessary. The minimum applicable load is the N-level reference value. This value indicates the malfunction reference level for the reliability level of 60% (λ_{60}). The equation $\lambda_{60} = 0.5 \times 10^{-6}/\text{operations}$ indicates that the estimated malfunction rate is less than 1/2,000,000 operations with a reliability level of 60%.

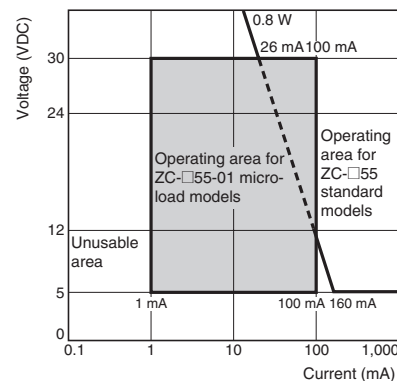

Model	ZC-□55-01	ZC-□55
Minimum applicable load	1 mA at 5 VDC	160 mA at 5 VDC

ALL DIMENSIONS SHOWN ARE IN MILLIMETERS.
To convert millimeters into inches, multiply by 0.03937. To convert grams into ounces, multiply by 0.03527.